

Project Manual and Bid Documents

For:

2023 Summer Roofing Projects

At:

Northfield Elementary School Sections A, C & I
Rushwood Elementary School Sections D (Area
Identified) E, E1, & E4 The Identified Area
Nordonia Middle School- Section J

Bid Date: 3/17/23 at 11:00

**Nordonia Hills City School District
9370 Olde Eight Rd.
Northfield, OH 44067**

**Casey Wright
Director of Business**

**Matt Brown
Treasurer**

LEGAL NOTICE

Sealed bids for furnishing all labor, material and equipment necessary for and incidental to the construction of: **NORDONIA HILLS CITY SCHOOLS SUMMER ROOFING PROJECT 2023**

**Northfield Elementary School Sections A, C, & I
9374 Olde Eight Rd.,
Northfield, OH 44067**

**Rushwood Elementary School Sections D (Area Identified) E, E1, & E4 and the
8200 Rushwood Lane
Northfield, OH 44067**

**Nordonia Middle School
73 Leonard Lane
Northfield, OH 44067**

will be received by the Treasurer/Business Director of the Board of Education, Nordonia Hills City School District, at the Board Office, located at 9370 Olde Eight Rd., Northfield, OH 44067 until **11:00 local time, 3/17/23**, where bids will be publicly opened and read aloud.

Bids will be received for: SUMMER 2023 ROOFING PROJECTS

Each bid must be accompanied by a Combination Bid Guaranty and Contract Bond in the sum of 10% of the amount of the Base Bid and all Alternates. Separate Bid Bonds are permitted.

There will be a **pre-bid meeting at 10:00 a.m. on 3/6/23** at Nordonia Elementary School, 9374 Olde Eight Rd., Northfield, OH 44067. Bid documents will be not distributed at this meeting. They will be emailed. Hard copies are available upon request. Bidders are responsible for all information obtained at this meeting.

The attention of bidders is also directed to the Equal Employment Opportunity regulations, which are applicable to this project. Successful bidder will be required to complete necessary background checks.

This legal notice can be found by accessing the Akron Beacon Journal on 2/24/23 & the districts website: <https://www.nordoniaschools.org>

If, in the opinion of the Board or its delegated representative, the acceptance of the lowest bid is not in the best interest of the Board, the Board may accept another proposal or reject all proposals and advertise for other bids. No bid may be withdrawn for a period of 60 days after closing time for receipt of bids.

The Board reserves the right to accept or reject any or all bids, to waive any informality in bidding and to accept any bid deemed most favorable to the School District.

Casey Wright, Director of Business
Nordonia City Schools

Advertise: **TBD and posted on the district website**

TABLE OF CONTENTS

SECTION 00700 GENERAL CONDITIONS

PART 1 - GENERAL

- 1.1 DEFINITIONS
- 1.2 OWNER'S REPRESENTATIVE STATUS
- 1.3 CONDITON OF SITE
- 1.4 VERIFICATION OF DIMENSIONS AND ELEVATIONS
- 1.5 PROTECTION OF WORK AND PROPERTY
- 1.6 MATERIAL STORAGE AND CLEAN-UP
- 1.7 INSPECTON OF WORK
- 1.8 INSPECTION OF WORK IN PROGRESS AND UPON COMPLETION
- 1.9 MISCELLANEOUS UTILITIES
- 1.11 CHANGES OR EXTRA WORK
- 1.12 CORRECTION OF WORK PRIOR TO FINAL PAYMENT
- 1.13 CORRECTION OF WORK AFTER FINAL PAYMENT CONTINUED
- 1.14 DEDUCTION FOR UNCORRECTED WORK
- 1.15 LIENS
- 1.16 JOB CONDITION
- 1.17 WORKMANSHIP
- 1.18 INSULATION
- 1.19 ROOF DECK
- 1.20 SAFETY
- 1.21 INSURANCE
- 1.22 WORK HOURS AND DAYS
- 1.23 COMPLIANCE WITH LAWS
- 1.24 OWNER'S RULES
- 1.25 SAFETY AND ECOLOGY
- 1.26 ANTI-DESCRIMINATION IN EMPLOYMENT

PART 2 - INSTRUCTIONS TO BIDDERS

- 2.1 WITHDRAWAL OR MODIFICATION OF BID
- 2.2 BID OPENINGS
- 2.3 QUESTIONS
- 2.4 RESPONSIBILITY FOR MEASUREMENTS AND QUANTITIES
- 2.5 DISCREPANCIES AND ADDENDA
- 2.6 COMPENTENCY OF THE BIDDER
- 2.7 DISQUALIFICATION OF BIDDERS
- 2.8 NOTICE OF AWARD
- 2.9 WARRANTY
- 2.10 START AND COMPLETION DATE
- 2.11 PAYMENT
- 2.12 PERFORMANCE AND PAYMENT BOND
- 2.13 TERMINATION BY THE OWNER FOR CAUSE
- 2.14 COMPLIANCE WITH LAWS

PART 3 - CONTRACTORS INSTRUCTIONS

- 3.1 TAXES
- 3.2 CONTRACTOR'S LICENSE
- 3.3 QUALIFICATION OF BIDDERS
- 3.4 BUILDING PERMITS
- 3.5 JOB COORDINATION
- 3.6 CLEAN-UP

- 3.7 SUPERINTENDENT
- 3.8 INSPECTIONS

PART 4 - STATEMENT OF POLICY

- 4.1 ENGINEERING
- 4.2 GUARANTEES
- 4.3 APPROVED CONTRACTORS
- 4.4 ROOFING SEQUENCE
- 4.5 ACCEPTABILITY OF COMPLETED WORK
- 4.6 ENGINEERING AND ROOF DECK
- 4.7 ASBESTOS IDENTIFICATION
- 4.8 ASBESTOS LIMITATIONS

SECTION 010100 – SUMMARY OF WORK

SECTION 061000 – ROUGH CARPENTRY

SECTION 072200 - ROOF DECK AND INSULATION

SECTION 075500 - 2 PLY MODIFIED ROOFING MEMBRANE

SECTION 076000 – SHEET METAL FLASHING AND TRIM

PART 5- CONTRACTOR'S QUALIFICATION STATEMENT (*TO BE SIGNED AND NOTARIZED*).

ROOFING MANUFACTURER CHECKLIST

BID GUARANTEE AND CONTRACT BOND

AFFIDAVIT

PERSONAL PROPERTY TAX VERIFICATION STATEMENT

SCOPE OF WORK

MAP OF FACILITIES

DETAIL DRAWINGS

BID FORM

THE END

SECTION 00700

GENERAL CONDITIONS

PART 1 GENERAL

1.1 DEFINITIONS

- A. The contract document consists of the AGREEMENT, the GENERAL CONDITIONS of the contract, the DRAWINGS and the SPECIFICATIONS, including all revisions hereto.
- B. The Owner, the Contractor and the Owner's Representative shall be indicated as such throughout these documents. The term Contractor as used herein shall designate the successful bidder to whom the roof contract is awarded.
- C. The term Owner shall be understood to be The Nordonias Hills City School District.
- D. The term Owner's Representative shall be understood to mean the representative of the primary material manufacturer.

1.2 OWNER'S REPRESENTATIVE STATUS

- A. The Owner's Representative shall have general Rights of Inspection of the work and is the agent of the Owner in all matters pertaining to the work as provided in the Contract Documents. The Owner's Representative has the authority to stop work whenever such stoppage may be necessary to ensure the proper execution of the contract and shall have authority to reject any and all materials, whether worked or unworked, if such materials are not in accordance with the plans and specifications.

1.3 CONDITION OF SITE

- A. The bidders shall visit the site before submitting their bids and determine the field conditions affecting their work. In considering the bids, the Owner will assume that the bidders are aware of all items, pertinent to their work and have made allowance for same in their bids.

1.4 VERIFICATION OF DIMENSIONS AND ELEVATIONS

- A. Dimensions and elevations indicated on the drawings in reference to existing structures or utilities are the best available data but are not guaranteed by the Owner's Representative and the Owner's Representative will not be responsible for their accuracy. Before bidding on any paperwork dependent upon the data involved, the Contractor shall field check and verify all dimensions, grades, lines, levels or other conditions of limitations at the site to avoid construction errors. If any work is performed by the Contractor or any of his/her subcontractors prior to adequate verification or applicable data, any resultant extra cost for adjustment of work as required to conform to existing limitations, shall be assumed by the Contractor without reimbursement or compensation by the Owner.

1.5 PROTECTION OF OWNER'S OPERATIONS

- A. The Contractor shall erect such barriers, tarpaulins, doors, etc., as may be necessary to protect the Owner's operations while work is in progress. Any such

openings that are essential to carrying on the work shall be securely closed by the Contractor when not in use to protect the Owner's operations.

1.6 PROTECTION OF WORK AND PROPERTY

- A. The Contractor shall maintain adequate protection of all his/her work from damage and shall protect the Owner's and adjacent property from injury or loss arising from this contract. He/she shall provide and maintain at all times any danger signs, guards and/or obstructions necessary to protect the public and his/her workmen from any dangers inherent with or created by the work in progress. He/she shall hold the Owner harmless from any loss arising due to injury or accident to the public or his/her workmen, or from theft of materials stored at the job site. All materials will be stored in locations other than on roof surfaces except as necessary and shall then be placed on plywood or other type of material to protect the roof surface at all times.
- B. Before starting any work, the Contractor shall protect all grounds, copings, paving and exterior of all buildings where work will be performed.
- C. In those areas where materials and/or hot asphalt will be raised to the roof area, a protective covering shall be placed from the base of the wall extending up and over the top edge of the roof. This coverage shall be wide enough to assure that the exterior walls do not become stained or soiled during roofing operations.
- D. Any areas of the building or grounds which have become stained or damaged in any way shall be repaired or replaced by the Contractor prior to the final inspections. The method of repair used must be acceptable to both the Owner and the Owner's Representative.

1.7 MATERIAL STORAGE AND CLEAN-UP

- A. The Contractor shall keep the premises free from rubbish at all times and shall arrange his/her material storage so as not to interfere with the Owner's operations. At the completion of the job, all the unused material and rubbish shall be removed from the site. The ground shall be raked clean and the building shall be broom cleaned. If the Contractor refuses at any time to remove his/her debris from the premises, or to keep the working area clean, such cleaning will be completed by the Owner and deducted from the balance due the Contractor.
- B. The Contractor shall also remove drippage of bitumen or adhesive from all walls, windows, floors, ladders and finished surfaces. Failure to do so will result in the work being done by others and the cost shall be deducted from the balance due the Contractor.
- C. Materials must be delivered with manufacturer's label in tact and legible. Labels must be affixed to the outside of the package stating the type of product, name and address of the manufacturer. All materials shall be stored and protected against weather, vandalism, and theft. Any materials found to be damaged or missing shall be replaced by the Contractor at no cost to the Owner.

1.8 INSPECTION OF WORK

- A. Where the drawings or specifications require the inspection and approval of any work in progress by the Owner's Representative, the Contractor shall give that Representative ample notice to allow for scheduling the inspection, which shall be made promptly to avoid delay of work. If work has progressed without the required inspections or approval by the Representative, it shall be uncovered for inspection at the Contractor's expense.
- B. Uncovering of work not originally inspected, or uncovering questioned work may be ordered by the Owner's Representative and it shall be done by the Contractor. If examination proves such work to be incorrectly done or not done in accordance with the plans and specifications, the Contractor shall bear all cost of the reexamination. If the work is proven correctly installed, all such expense shall be born by the Owner.

1.9 INSPECTION OF WORK IN PROGRESS AND UPON COMPLETION

- A. If directed by the Owner's Representative, the Contractor shall cut not more than four (4) cores, of approximately 200 square inches each, from every newly constructed roof area, in order to establish the amount of materials used per square foot, and shall restore all such areas to sound and watertight conditions as prior to the core testing.
- B. In the event that such core cuts disclose any deficiency in materials, or soundness of construction, the Contractor shall, at his/her own expense, apply additional materials or otherwise correct the deficiencies to the satisfaction of the Owner's Representative.
- C. Noncompliance with the terms of this specification and ensuing contract can result in either the cancellation of the contract, or complete replacement of the defective areas at the Contractor's expense. In the event of cancellation, the Owner will not be obligated to compensate the Contractor for any work undertaken in a defective manner
- D. Damages caused by water infiltration resulting from the failure of the Contractor to secure each day's work in a weather tight manner, will be corrected at the Contractor's expense. Included as damages will be all labor costs incurred by the Owner as a result of such water infiltration.
- E. The Owner will require the Owner's Representative to examine the work in progress, as well as upon completion, in order to ascertain the extent to which the materials and procedures conform to the requirements of these specifications and to the published instructions of the Manufacturer.
- F. The authorized Owner's Representative shall be responsible for:
 - 1. Keeping the Owner informed on a periodic basis as to the progress and quality of the work;
 - 2. Calling to the attention of the Contractor those matters he/she considers to be in violation of the contract requirements;
 - 3. Reporting to the Owner any failure or refusal of the Contractor to correct unacceptable practices;
 - 4. Conducting preliminary and subsequent job-site meetings with the Contractor's official job representative;
 - 5. Supervising the taking of test cuts, and the restoration of such areas;
 - 6. Rendering any other inspection services which the Owner may designate; and

7. Certifying, after completion of the work, the extent to which the Contractor has complied with these specifications as well as to the published instructions of the Manufacturing Company.
- G. The presence and activities of the Owner's Representative shall in no way relieve the Contractor of his/her contractual responsibilities.

1.10 MISCELLANEOUS UTILITIES

- A. Electrical power will be furnished by the Owner for small tools only. All connections to the electrical system will be furnished by the Contractor.
- B. Water for concrete, mortar, washing and drinking purposes will be furnished by the Owner. Any connections to the water system shall be completed by the Contractor.
- C. At the completion of the work, or when the above connections are no longer required, the Contractor shall remove all connections and leave the facilities in a condition at least as satisfactory as prior to the commencement of his/her work.
- D. Toilet facilities will be provided by the Contractor. The Contractor will be responsible for supplying a portable toilet on the job-site. The Contractor's personnel are not permitted to enter the building without proper authorization from the Owner or Owner's Representative.

1.11 CHANGES OR EXTRA WORK

- A. The Owner may, without invalidating the original contract, order such changes or additions as may from time to time be deemed desirable. In so doing, the contract price shall be adjusted, as stated below, with all work being done under the conditions of the original contract except for such adjustments in extension of time as may be acceptable to the Owner. The value of such extra work shall be determined in one of the following ways:
 1. By unit cost.
- B. If agreement is reached that the extra cost shall be handled as per methods 2, 3, or 4, the Contractor shall keep and compile a correct amount of the cost together with such vouchers, etc., as may be necessary to substantiate same for presentation to the Owner. The Owner's Representative shall have authority to make minor job changes or additions as may be necessary to expedite the job providing such changes do not involve additional material cost. No major change or addition shall be made except upon receipt by the Contractor of a signed order from the Owner authorizing such a change. No claims for an extra to the contract price shall be valid unless so authorized.
- C. All work covered by unit prices submitted by the Contractor in his/her proposal must be covered by a written work order. The Owner's Representative will prepare the work order in triplicate covering the quantity of work and the total cost of the work. The work order which will be written at the end of each day, will be signed by the Owner's Representative and the Contractor's foreman and/or superintendent.

1.12 CORRECTION OF WORK PRIOR TO FINAL PAYMENT

- A. The Contractor shall promptly remove any work that does not meet the requirements of the plans and specifications or is incorrectly installed or otherwise disapproved by the Owner or the Owner's Representative as failing to meet the intent of the plans

and specifications. The Contractor shall promptly replace any such work without expense to the Owner and shall bear the cost of making good all work of other contractors, or the Owner, destroyed or damaged by such removal or replacement.

1.13 CORRECTION OF WORK AFTER FINAL PAYMENT

- A. The Contractor shall guarantee all materials and workmanship for two (2) years from date of final payment of the contract by the Owner. Any defects which may arise during this period shall be promptly repaired by the Contractor including any damage done to the Owner's property due to such defects.

1.14 DEDUCTION FOR UNCORRECTED WORK

- A. If the Owner deems it unacceptable to have the Contractor correct work which has been incorrectly done, a deduction from the contract price shall be agreed upon therefore. Such a deduction from the contract price shall in no way affect the Contractor's responsibility for defects which may occur nor his/her ability for correcting them, and damage caused by them.

1.15 LIENS

- A. The Contractor shall, if required by the Owner, furnish him/her with a release in full of all liens arising out of this contract or in lieu thereof, and receipts in full for all materials and labor on the job. In either case, the Contractor shall furnish an affidavit that the liens or receipts include all the labor and material for which a lien could be filed. In lieu of the above, the Contractor may at his/her option furnish a bond to indemnify the Owner against all hazard of liens. Neither part nor final payment shall in any way release the Contractor from the above obligation and in the event that part or full payment has been made and any lien remains undischarged, the Contractor shall refund to the Owner the necessary funds to discharge such a lien including all cost and attorney's fees.

1.16 JOB CONDITIONS

- A. All surfaces to be covered shall be smooth, dry, and free from dirt, debris, and foreign material before any of this work is installed. Pumping equipment shall be located on the ground at a safe distance from building; the location being subject to the approval of the Owner. The Contractor shall be responsible for guarding against fires, and shall provide suitable fire extinguishers conveniently located at the site. Competent operators shall be in attendance at all times equipment is in use. Materials shall be stored neatly in areas designated by the Owner and dispersed so as to present a minimum fire hazard. Loads placed on the roof at any point shall not exceed the safe load for which the roof is designed.
- B. There is **NO SMOKING allowed on school grounds** and the Contractor shall be responsible for enforcement of this job rule at all times with his/her personnel.
- C. The Contractor should be aware of Owner's property when tearing off the existing roof. This is required for removal of dirt, silt, debris, roof membrane and insulation from the roof surface in order to preserve the ecology, eliminate unsightly conditions and protect building faces. Specific locations will be discussed at the pre bid conference.
- D. Rolled Roofing Materials: All rolled roofing materials must be stored standing on end on a pallet or otherwise raised off of the roof. The materials are to be covered in a proper manner to assure that they will not become wet prior to application. Any

materials that become wet or damaged must be removed from the job-site and replaced at the Contractor's expense.

- E. Asphalt Kettle: Placement of the kettle shall be in a position so as not to interfere with the ongoing operations of the Owner. The asphalt to be used must be placed on a protective covering of some type until it is raised to the roof. A minimum of two (2) fire extinguishers and "Fire Out" must be adjacent to the kettle.
- F. Ladders: Any ladders used on this project must be in good condition. The ladder must also be secured at the roof line at all times while in use. All ladders must be O.S.H.A. approved.
- G. No drugs or alcoholic beverages are permitted on the grounds.
- H. The Contractor shall place necessary barriers and/or protection around or under all work areas where his/her operations involve risk of injury to plant.
- I. The Contractor will also protect the building structure from damage in the process of the job. In the event that damage does occur to any property or equipment, or the Owner's work in process, notification must be made within two (2) working days of the incidents to the Owner and Owner's Representative.
- J. During the progress of the job, if waste material and rubbish are found or damage resulting from the Contractor's operations is found, or the Contractor does not comply with the requirement by keeping the premises free of accumulations and correct the damage, it shall be the Owner's prerogative to hire personnel to do so; and the cost of this work will be deducted from the balance due the Contractor.
- K. Existing roof top equipment walls, windows, etc. shall be completely protected by masking or other effective methods. Any mastics or asphalt must be cleaned off metal surfaces.
- L. The Contractor is responsible for protecting all materials from the elements. If any material, such as insulation, becomes wet, it cannot be installed and must be replaced at the Contractor's expense. NOTE: Insulation and rolled roofing materials must be covered with waterproof tarps at the end of each work day. Plastic wrappers supplied by the insulation manufacturer are not acceptable substitutes for tarps. The Owner's Representative will reject any covering method material which does not adequately protect roofing materials.
- M. Anyone guilty of willful destruction or unlawful removal of company property will be dismissed from the job and is subject to prosecution by law.
- N. Any lawns damaged by Contractor vehicles will be restored with a stand of grass at the Contractor's expense. Any damaged pavements will likewise be restored at the Contractor's expense.
- O. The Contractor must verify that all materials can be installed to accommodate the building design, pertinent codes and regulations, and the manufacturer's current recommendations.
- P. The Contractor will ensure that all substances are clean, dry, sound, smooth, and free of dirt, debris, and other contamination before any materials are supplied.
- Q. Any isolated areas that must be torn off and replaced will be built-up to the height of the existing roof prior to the installation of the new roofing membrane system.

1.17 WORKMANSHIP

- A. All materials will be securely fastened and placed in a watertight, neat and workmanlike manner. All workmen shall be thoroughly experienced in the particular class or work upon which they are employed. All work shall be done in accordance with these specifications and shall meet the approval of the Owner or Owner's Representative. The Contractor's representative or job supervisor shall have a complete copy of specifications and drawings on the job-site at all times.
- B. Contractor shall plan and conduct the operations of the work so that each section started on one day is complete and thoroughly protected before the close of work for that day.

1.18 INSULATION

- A. Insulation shall have accurate dimensional stability so as to properly conform to the surfaces of the roof, cants, curbs, pipes, etc. Joints between boards shall be tight and insulation shall be held back ½" from vertical surfaces and sumps. Insulation shall be protected from the weather at all times. No more insulation shall be laid than can be completely covered with roof materials on the same day. A base sheet shall not be considered as a proper weather barrier.
- B. Insulation that becomes wet during or after installation shall be removed and replaced with dry insulation. If roofing is in place, the roofing shall be also replaced. All replacing work shall be done at no added cost to the Owner.
- C. **The owner is providing a portion of the 2.2" polyisocyanurate (ISO) insulation. The contractor is responsible for all insulation saddles, crickets and tapered ISO insulation, and all insulation that is not 2.2" thick.**

1.19 ROOF DECK

- A. Contractor shall notify the Owner or Owner's Representative of any unforeseen areas of wet insulation. Where the damage is serious and extensive, it will be the Owner's prerogative to authorize removal and replacement of deteriorated roofing, insulation and repair of the vapor barrier, if present. Where damage to the roof deck is found, the Contractor shall furnish the Owner with a unit price for removal and replacement of the damaged deck.

1.20 SAFETY

- A. Contractor shall conform to requirements as designated by the United States Federal Government (O.S.H.A.). Contractor shall abide by all regulations as outlined in the O.S.H.A. handbook and shall have a handbook on location at all times.
- B. Contractors hereby acknowledged that they and their workers have undergone Safety Training and shall at all times act in compliance with all NRCA recommended safety compliance rules and regulations.

1.21 INSURANCE

- A. The following standard indemnity agreement and minimum insurance requirements are incorporated in the Specifications for all work performed by Contractors for the Owner, its affiliated and associated organizations or subsidiaries, hereinafter referred to as Owner.
1. THE CONTRACTOR AGREES TO INDEMNIFY AND SAVE THE OWNER AND OWNER'S REPRESENTATIVE HARMLESS FROM AND AGAINST ANY AND ALL COSTS, LOSS AND EXPENSE, LIABILITY DAMAGES, OR CLAIMS FOR DAMAGES, INCLUDING COST FOR DEFENDING ANY ACTION, ON ACCOUNT OF ANY INJURY TO PERSONS (INCLUDING DEATH) OR DAMAGE TO OR DESTRUCTION OF PROPERTY OF THE OWNER, ARISING OR RESULTING FROM THE WORK PROVIDED FOR OR PERFORMED, OR FROM ANY ACT, OMISSION, OR NEGLIGENCE OF THE CONTRACTOR, SUBCONTRACTOR AND THEIR AGENTS OR EMPLOYEES. THE FOREGOING PROVISIONS SHALL IN NO WAY BE DEEMED RELEASED, WAIVED OR MODIFIED IN ANY RESPECT BY REASON OF ANY INSURANCE OR SURETY PROVIDED BY THE CONTRACTOR.
 2. All sub-contractors are required to file Certificated of Insurance properly completed and signed by an authorized insurance company representative before their work commences on the job or job site. No monies will be paid until the acceptable certificates are on file with the Contractor. Such certificates shall provide that there will be no cancellation, reduction or modification of coverage without thirty (30) days prior written notice to the Contractor. In the event such certificates are not provided to the Contractor prior commencement of work, Contractor's failure to demand such certificates shall not be deemed a waiver of Subcontractor's requirement to obtain the subject insurance.
 3. The Contractor shall provide and maintain standard fire, extended coverage perils, vandalism and malicious mischief insurance to protect the interest of both the Contractor and the Owner for materials brought into the job or stored on the premises. Such insurance shall be for 100% of the insurable value of the work to be performed including all items of labor and materials incorporated therein, materials stored at the job-site to be used in completing the work, and such other supplies and equipment incidental to the work as are not owned or rented by the Contractor, the cost of which are included in the direct cost of the work. This insurance shall not cover any tools, derricks, machinery, tar buckets, ladders, engines, workmen's quarters, boilers, pumps, wagons, scaffolds, forms, compressors, shanties, or other items owned or rented by the Contractor, the cost of which is not included in the direct cost of the work.
 4. In accordance with Section (1.21), the Contractor and subcontractor(s) shall maintain the following insurance:
 - a. Workmen's Compensation and Employer's Liability Insurance affording:
 - 1) Protection under the Workmen's Compensation Law of the States in which the work is performed; and
 - 2) Employer's Liability protection subject to a minimum limit of \$100,000.
 - b. Comprehensive General Liability Insurance in amounts not less than:
 - 1) Personal Injury: \$1,000,000 per person (including bodily injury) \$1,000,000 per occurrence
 - 2) Property Damage: \$1,000,000 per occurrence
 - c. Comprehensive Automobile Liability Insurance in the following minimum amounts:
 - 1) Bodily Injury \$1,000,000 per person

- \$1,000,000 per occurrence
- 2) Property Damage \$1,000,000 per occurrence
- d. This insurance shall:
 - 1) Include coverage for the liability assumed by the Contractor under this section (section 1.21.A.1) (Indemnity);
 - 2) Includes coverage for:
 - a) Premises, operations and mobile equipment liability
 - b) Completed operations and products liability
 - c) Contractual liability insuring the obligation assumed by the subcontractor in this agreement.
 - d) Liability which subcontractor may incur as a result of the operations, acts or omissions of subcontractors, suppliers or material men and their agents or employees; and
 - e) Automobile liability including owned, non-owned and hired automobile.
- e. All coverage will be on an occurrence basis and on a form acceptable to the Contractor.
 - 1) Include completed operation coverage which is to be kept in force by the Contractor for a period of not less than one year after completion of the work provided for or performed under these specifications;
 - 2) Not be subject to any of the special property damage liability exclusions commonly referred to as the exclusions pertaining to blasting or explosion, collapse or structural damage and underground property;
 - 3) Not be subject to any exclusion of property used by the insured or property in the case, custody or control of the insured or property as to which the insured for any purpose is exercising physical control; and
 - 4) The Certificate of Insurance furnished by the Contractor shall show specific reference that each of the foregoing items have been provided for.
- 5. The Certificates of Insurance furnished by the Contractor as evidence of the Insurance maintained by him shall include a clause obligating the Insurer to give the Owner thirty (30) days prior written notice or cancellation of any material change in the insurance.
- 6. **The insurance coverage shall list The Nordonia Hills City School District as additional insured.**

1.22 WORK HOURS AND DAYS

- A. When the Contract is awarded, the Contractor will contact the Owner's Representative to arrange the work schedule and the hours of the day that the workmen may be on the building. The job is to be bid under the assumption that all work will be performed on a straight time basis.

1.23 COMPLIANCE WITH LAWS

- A. The Contractor shall give notices, pay all fees, permits and comply with all laws, ordinances, rules and regulations bearing on the conduct of work.

1.24 OWNER'S RULES

- A. The Contractor and all his/her personnel/agent(s) shall abide by all rules created by the Owner. The Contractor must contact the Owner's Representative for specific information regarding the rules governing all operations of the project.
- B. The Contractor shall properly notify all employees of conditions relating to roof areas with very poor condition and which will be worked on. After such notification, the Contractor must take all necessary precautions to ensure the safety of his/her employees as well as the building personnel.
- C. THE CONTRACTOR SHALL "HOLD HARMLESS" THE MATERIAL MANUFACTURER, AGAINST ANY LITIGATION ARISING FROM ANY ACCIDENTS DURING THE COURSE OF THE CONTRACT.

1.25 SAFETY AND ECOLOGY

- A. The Contractor(s) shall conform to the requirements as designated by the United States Federal Governments (e.g., O.S.H.A).

1.26 ANTI-DISCRIMINATION IN EMPLOYMENT

- A. Contractors and subcontractors shall not discriminate against any employees or applicant for employment, to be employed in performance of his/her contract, with respect to his/her hire, tenure, terms, conditions or privileges of employment because of his/her race, color, gender, sexual preference, religion, national origin, or ancestry.

PART 2 INSTRUCTIONS TO BIDDERS

2.1 WITHDRAWAL OR MODIFICATION OF BID

- A. Any Bidder may withdraw his/her bid at any time before the scheduled closing date of the bid by appearing in person or by sending an authorized representative of the Bidder. An appointment should first be scheduled by calling the Owner's Representative. The Bidder or his/her representative shall be asked to sign, in writing that the bid was returned to him/her/ after the withdrawal from the contract, the Bidding Contractor may not resubmit them.

2.2 BID OPENINGS

- A. **Bids will be opened publicly and read aloud at the Board Office, located at 9370 Olde Eight Rd., Northfield, OH 44067 at 11:00 local time, 3/17/23.** Notice of award will be made by written correspondence.

2.3 QUESTIONS

- A. Technical questions regarding this bid can be directed to: Rick Wolf (216) 244-0977 rick.wolf@nordoniaschools.org.
- B. If the Contractor feels a conflict exists between what is considered good roofing practice and these specifications, he/she shall state in writing all objections prior to submitting quotations.
- C. It is the Contractor's responsibility, during the course of the work, to bring to the attention of the Owner's Representative any defective membrane, insulation or deck discovered which has not been previously identified.

2.4 RESPONSIBILITY FOR MEASUREMENTS AND QUANTITIES

- A. The Bidding Contractors shall be solely responsible for all accuracy of all measurements and for estimating the material required to satisfy these specifications.

2.5 DISCREPANCIES AND ADDENDA

- A. Should a Bidder find any discrepancies in the Drawings and Specifications, or should he be in doubt as to their meaning, he/she shall notify the Owner's Representative at once, who will send a written Addendum to all Bidders concerned. Oral instructions or decisions, unless confirmed by Addenda, will not be considered valid, legal or binding.
- B. No extras will be authorized because of the Contractor's failure to include work called for in the Addenda in his/her bid.
- C. It shall be the responsibility of all Bidders to call to the Owner's Representative's attention at the pre bid meeting, any discrepancies which may exist between or with any of the contract documents, or any questions which may arise as to their true meaning.
- D. Modifications to the specifications (if necessary) will be followed by an addendum; no verbal discussions or agreements shall be recognized.

2.6 COMPETENCY OF THE BIDDERS

- A. To enable the Owner to evaluate the competency and financial responsibility of a Contractor, the low Bidder shall, when requested by the Owner, furnish the information indicated in Section 5.0 below, entitled Contractor's Qualification Statement, which shall be sworn to under oath by him/her or by a properly authorized representative of the Bidder.

2.7 DISQUALIFICATION OF BIDDERS

- A. Any one or more of the following causes may be considered sufficient for the disqualification of a Bidder and the rejection of his/her bid(s):
 1. Failure to attend the pre bid meeting;
 2. Evidence of collusion among Bidders;
 3. Lack of responsibility as revealed by either financial, experience or equipment statements, as submitted;
 4. Lack of expertise as shown by past work, and judged from the standpoint of workmanship and performance history;
 5. Uncompleted work under other contracts which, in the judgment of the Owner, might hinder or prevent the prompt completion of additional work if awarded;
or
 6. Being in arrears on existing contracts, in litigation with an Owner, or having defaulted on a previous contract.

2.8 NOTICE OF AWARD

- A. The award of this contract for the work is contingent upon receipt of an acceptable bid. Any part of or all bids may be rejected. All bids shall be good for a period of sixty (60) days following the date the bids are due. The contract shall be deemed as having been awarded when the formal notice of acceptance of his/her proposal has been duly served upon the intended awardee by an authorized officer or agent of the Owner.

2.9 WARRANTY

- A. A written warranty which will commence from date of acceptance by Manufacturer must be supplied with the roof installation. This warranty will cover all defects in workmanship and materials. Damages caused by storm, vandalism and other trades are not included in the warranty. This warranty shall be from the manufacturer (See further, Statement of Policy).
- B. A two (s) year workmanship warranty is required from the Contractor for all remedial maintenance done under the terms of this contract.

2.10 START AND COMPLETION DATE

- A. **Work shall begin on 6/4/23.**
- B. **All work as required in these specifications and drawings shall be completed by 8/18 or as agreed upon by the parties. Project delays because of supply chain issues can be discussed. The issues must be supported with proper documentation.**
- C. The Contractor is responsible for supplying trained workmen in proper numbers and for scheduling and laying out his/her work, so that it will be started and completed in a professional manner within the time period indicated on his/her Proposal form.
- D. If the Contractor sets equipment onto the job-site without commencing work immediately, the action will be considered "Spiking the job" which is unacceptable and will be considered a breach of contract by the Contractor; thereby, the contract will be terminated and the Contractor at no cost to the Owner, must remove his/her equipment and possessions from the job-site upon notification by the Owner.

2.11 PAYMENT

- A. Payment for materials shall only be made after the material has been delivered to the job-site. An invoice for the material must be presented to the Owner for payment. Materials are not to be delivered to the job-site until the project is ready to begin. The Contractor must provide a release of lien from the Material Manufacturer. Subsequent requests for payment can be made monthly. Final payment for the project will be made following completion, after final inspection has been made and an invoice presented to the Owner. A 10% retainer shall be held until delivery of the warranty.
- B. When the job in progress is interrupted for two (2) weeks or longer by causes beyond the Contractor's control such as a strike, weather, acts of God, etc., the Owner agrees to pay, upon request of the Contractor, a price equivalent to the percentage of work completed at that time. Regular progress payments shall be made for labor and/or materials.
- C. Each invoice shall be accompanied by a detailed estimate of the amounts and values of labor expended and materials purchased up to the last day of the preceding month. The amount of the invoice shall not exceed ninety percent (90%) of the labor and material values estimated for the preceding month.
- D. Such payments shall be viewed by both parties as progress payments and shall not in any way relieve the Contractor of performance obligations under this contract, nor

shall such payments be viewed as approval or acceptance of work performed under this contract.

- E. Final payment shall be withheld until all provisions of the specifications are met, including all necessary clean-up, and the Owner receives written verification of completion.
- F. Upon completion of the job, the Owner, the Owner's Representative, and the Contractor will make final inspection of the work done, and the Owner's Representative if requested by Owner's Representative.
- G. All payments for material used in the execution of this contract can be made by a check issued jointly, payable to the Contractor and Owner's Representative will sign a completion slip authorizing final payment.
- H. If requested by the Owner and/or Owner's Representative, the Contractor shall provide a Letter of Credit from the bank to secure payment to material supplier.
- I. If requested by the Owner and/or Owner's Representative, a certified check shall be paid by the Contractor to material supplied prior to release of order.
- J. If requested by the Owner and/or Owner's Representative, a certified check shall be paid by the Contractor to material supplier via common carrier upon receipt of delivery.
- K. Contractor shall have a pre-approved line of credit from the material supplier.
- L. Final payment shall be made to the Contractor no later than thirty (30) days after job approval, providing the Contractor submits waivers of lien with his/her final invoice indicating that all suppliers have been paid.

2.12 PERFORMANCE AND PAYMENT BOND

- A. The successful Contractor will be responsible for securing a performance and payment bond from an acceptable bonding company. The cost of the bond will be paid directly by the Contractor. Contractor has to identify his/her bonding company and agent, submitting this documentation with his/her proposal. Note: See "Instruction to Bidders."
- B. Financial documentation prescribed by the Owner to ensure that the Contractor is financially sound and capable of supporting the project to its conclusion.
- C. If the successful Bidder is incorporated, an affidavit authorizing persons to sign for the Corporation. This should be in the form of minutes of the meeting of the Board of Directors, authorizing person or persons to sign for this contract work and indicating a quorum being present.

2.13 TERMINATION BY THE OWNER FOR CAUSE

- A. The Owner may terminate the contract and finish the work by whatever reasonable method he/she deems expedient if the Contractor:
 - 1. Persistently or repeatedly refuses to supply specified materials or to provide enough skilled workers to ensure the project will be completed within the time period indicated on his/her Proposal form;

2. Fails to make payment to sub-contractors and/or suppliers for labor and materials as stipulated in the contract documents; and
 3. Is guilty of substantial breach of a provision of the contract documents.
- B. When the Owner terminates the contract for any of the above reasons, the Contractor shall not be entitled to receive further payment until the work is finished. If the unpaid balance of the contract sum exceeds the cost of finishing the work, it will be paid to the Contractor. If the cost to finish the work exceeds the unpaid balance, the Contractor shall pay the difference to the Owner.

2.14 COMPLIANCE WITH LAWS

- A. The Contractor shall give notices, pay all fees, permits and comply with all laws, ordinances, rules and regulations bearing on the conduct of work.

PART 3 --- CONTRACTOR'S INSTRUCTIONS

3.1 TAXES

- A. Contractor must comply with all state, federal and local taxes. The Contractor shall accept sole and exclusive responsibility for any and all state federal taxes with respect to Social Security, old age benefits, unemployment benefits, withholding taxes and sales taxes.

3.2 CONTRACTOR'S LICENSE

- A. All pertinent state and local licenses will be required.

3.3 QUALIFICATION OF BIDDERS

- A. Provide State of (state here) pre-certification forms.

3.4 BUILDING PERMITS

- A. The acquisition of the applicable permits and associated costs to obtain said permits will be the responsibility of the successful Contractor.

3.5 JOB COORDINATION

- A. Contractor is responsible for daily communication with the Owner or Owner's Representative relating to areas of roof work in order that the Owner may adequately protect tenant's personal belongings, and the people themselves against possible damage or injury. Contractor is also responsible for policing and protecting areas involving removal and replacement of roof projections, defective decking or other work involving deck penetration.
- B. Twenty-four hours prior to starting of the project and/or delivery of materials, the Contractor shall notify: Mr. Bob Munroe (330) 676-8590.

3.6 CLEAN-UP

- A. Accumulated debris shall be removed periodically to assure maximum safety and sanitation at all times. At completion of work, the Contractor shall remove all excess material and debris from the site and leave all roof surfaces free from accumulations

of dirt, debris and other extraneous materials. The Contractor shall also remove any and all drippage of bituminous materials from the face of the buildings, floor, window, ladders and other finished surfaces.

3.7 SUPERINTENDENT

- A. The Contractor shall keep a competent superintendent, satisfactory to the Owner and Owner's Representative, on the job at all times when work is in progress. The superintendent shall not be changed without notifying the Owner and the Owner's Representative unless the superintendent ceases to be in the employ of the Contractor.
- B. The superintendent shall represent the Contractor in his/her absence and all directions and instructions given to the superintendent shall be as binding as if given directly to the Contractor.
- C. The superintendent shall be responsible for the conduct of all the Contractor's employees on the premises and shall promptly take necessary measures to correct any abuses called to his/her attention by the Owner.

3.8 INSPECTIONS

- A. Before any material applications are made, the Owner or his/her representative and the material supplier representative shall be available to ensure a complete understanding of the specification.
- B. The accepted Material Manufacturer will have an employee of that company (a 3rd party representative is not acceptable) on site **daily or as many as needed/requested** to verify compliance with the specifications, answer questions that may arise and provide on-going inspection services. A pictorial report outlining the day's activity shall be provide the same day as the site visit or as requested by the district. **The Nordon Hills City School District reserves the right to hire an inspector at the rate up to \$500 per day if the inspections are not met.**
- C. A final inspection shall be conducted by Owner, Contractor, and the Owner's Representative upon being notified of completion of specified work and clean-up.

PART 4 – STATEMENT OF POLICY

4.1 ENGINEERING

- A. In addition to high-quality products, the Material Manufacturer provides recommendations and/or specifications for the proper installation of its material. However, the Material Manufacturer does not, nor does its representative, practice engineering or architecture. The Material Manufacturer makes no judgments on, and hereby disclaim any responsibility for the soundness of any roof deck or other structural component of buildings upon which the Material Manufacturer products are applied, and further recommend a structural engineer to examine the deck conditions. Re-roofing or Ballasted Roofing Systems will require certification from a structural engineer that the structure will support the proposed additional weight.

4.2 GUARANTEES

- A. A roofing guarantee is available for review from the Material manufacturer for the roofing systems published in these specifications. The guarantee will be issued only upon completion of all the guarantee requirements by an approved Contractor. Such guarantees cannot be altered or amended, nor may any other warranties, guarantees

or representations be made by an agent or employee of the Material Manufacturer unless such alteration, amendment or additional representation is issued in writing and is signed by a duly authorized officer of the Material Manufacturer, and sealed with the Material Manufacturer seal. This guarantee does not cover cosmetic deficiencies. THE MATERIAL MANUFACTURER WILL NOT BE RESPONSIBLE FOR ANY DAMAGES TO THE BUILDING OR ITS CONTENTS OR ANY OTHER CONSEQUENTIAL DAMAGES, AND ITS RESPONSIBILITY IS LIMITED TO REPAIRING LEAKS. The Contractor will warranty the roof to the Material Manufacturer for a period of two (2) years. The Contractor will inspect the roof with the Owner's Representative 18 months after completion, and, at the Contractor's expense, correct any workmanship defects before the 24th month following completion of the project.

4.3 APPROVED CONTRACTORS

- A. The roof systems must be applied only by those contractors who have received approval from the Material Manufacturer for such installations. No guarantees will be issued when installation has been performed by a non-approved contractor.

4.4 ROOFING SEQUENCE

- A. Phase roofing is not acceptable. Any insulation or base layers laid in any one day must be covered with the properly installed roof system that same day. Failure to do so will void any warranties and no guarantee will be issued for the roofing system.

4.5 ACCEPTABILITY OF COMPLETED WORK

- A. The acceptability of completed roofing work will be based on its conformance to the contract requirement. The Material Manufacturer is not obligated to accept non-conforming work, and such non-conforming work may be rejected. The rejected work shall be promptly replaced or corrected in a manner and by methods approved by the Material Manufacturer at the Contractor's expense. The Material Manufacturer will instruct the Contractor's foreman and work crew on the proper methods of installation of the roofing system, and will follow-up on a regular basis to inspect the work being done. Any deficiencies from the specified work noted by the Material Manufacturer will be immediately reported to the Owner, along with recommended corrective actions necessary. The Material Manufacturer will not act in a supervisory capacity, and will not be responsible for the Contractor's errors or omissions.

4.6 ENGINEERING AND ROOF DECK

- A. The Material Manufacturer nor its representatives, practice engineering nor architecture. It makes no judgments on, and hereby disclaim any responsibility for the soundness of any roof deck or other structural component of buildings upon which its products are applied. Re-roofing and general building structuring require certification from a structural engineer that the structure will support the proposed additional weight. In addition, the Contractor must notify the Owner or his/her representative on the job-site of any unforeseen areas of wet insulation. Where the damage is serious and extensive, it will be the Owner's prerogative to authorize removal and replacement of deteriorated roofing, insulation and repair of the vapor barrier if present. Where damage to the roof deck is found, the Contractor shall furnish the Owner with a unit price for removal and replacement of the damaged deck.

4.7 ASBESTOS IDENTIFICATION

- A. The Material Manufacturer routinely conducts roof surveys and inspections in order to provide recommendations and/or specifications for the use of its products. However, the MATERIALS MANUFACTURER IS NOT, NOR ARE ITS REPRESENTATIVES, CERTIFIED TO IDENTIFY, HANDLE OR MONITOR ASBESTOS IN ROOFING, DECKING OR INSULATION. THEREFORE, IT MAKES NO JUDGMENTS ON AND HEREBY DISCLAIMS ANY RESPONSIBILITY FOR IDENTIFYING, HANDLING OR MONITORING ASBESTOS. If a building owner suspects that an asbestos condition exists on or under the roof area in question, Material Manufacturer can recommend licensed laboratories and technicians that can identify, remove, dispose of, and monitor the project.

4.8 ASBESTOS LIMITATIONS

- A. The Owner has been informed, acknowledges and agrees that Material Manufacturer is not engaged in the business of identifying, abating, encapsulating or removing asbestos or asbestos containing materials from the work site and has not agreed to do so herein.
- B. IN CONSIDERATION OF THE PROVISION HEREOF, THE OWNER HEREBY AGREES TO INDEMNIFY, DEFEND AND HOLD HARMLESS THE MATERIAL MANUFACTURER, ITS OWNERS, OFFICERS, DIRECTORS, EMPLOYEES AND AGENTS, INCLUDING THE ENGINEER FROM AND AGAINST ANY AND ALL LIABILITIES, DAMAGES, LOSSES AND EXPENSES (INCLUDING BUT NOT LIMITED TO ATTORNEY'S FEES) ARISING OUT OF, OR RELATING TO, ANY CLAIMS, DEMANDS, OR CAUSES OF ACTION OF ANY KIND,, ATTRIBUTABLE TO, ARISING OUT OF, OR RELATING TO THE PRESENCE OF ASBESTOS OR ASBESTOS-CONTAINING MATERIALS ON OR AT THE WORK SITE AND/OR THE ABATEMENT, ENCAPSULATION AND/OR THE REMOVAL THEREOF.

SECTION 010100
SUMMARY OF WORK

PART 1 - GENERAL

1.1 RELATED DOCUMENTS

A. Attached GENERAL CONDITIONS, BID FORM, forms a component part of this section.

1.2 SUMMARY OF WORK – per the provided scope of work.

1.3 INTENT OF THE SPECIFICATIONS

A. The intent of these specifications is to describe the material and methods of construction required for the performance of the work. In general, it is intended that the drawings shall delineate the detailed extent of the work. When there is a discrepancy between drawings, referenced specifications, and standards and this specification, this specification shall govern.

1.4 PROTECTION

A. The contractor shall use every available precaution to provide for the safety of the property owner, visitors to the site, and all connected with the work under the Contract.

B. All existing facilities both above and below ground shall be protected and maintained free of damage. Existing facilities shall remain operating during the period of construction unless otherwise permitted. All access roadways must remain open to traffic unless otherwise permitted.

C. Barricades shall be erected to fence off all construction areas from operations personnel.

D. Safety Requirements:

1. All application, material handling, and associated equipment shall conform to and be operated in conformance with OSHA safety requirements.

2. Comply with federal, state, and local and owner fire and safety requirements.

3. Advise owner whenever work is expected to be hazardous to owner employees and/or operations.

4. Maintain a crewman as a floor guard whenever roof decking is being repaired or replaced.

5. Maintain proper fire extinguisher within easy access whenever power tools, roofing kettles, and torches are being used. A MINIMUM OF A 2 HOUR FIRE WATCH SHALL BE STRICTLY ADHERED TO WHENEVER PROPANE TORCHES ARE IN USE.

6. ALL SAFETY REQUIREMENTS OF THE BUILDING OWNER MUST BE FOLLOWED. NO EXCEPTIONS WILL BE PERMITTED. SAFETY ORIENTATION MEETING REQUIRED PRIOR TO PERFORMING ANY WORK.

1.5 HOUSEKEEPING

- A. Keep materials neat and orderly.
- B. Remove scrap, waste and debris from the project area.
- C. Maintenance of clean conditions while work is in progress and cleanup when work is completed shall be in strict accordance with the "General Conditions" of this contract.
- D. Fire protection during construction.
- E. Follow all requirements established by the building owner.

END OF SECTION

SECTION 06 10 00
ROUGH CARPENTRY

PART 1 - GENERAL

1.1 RELATED DOCUMENTS:

- A. Drawings and general provisions of Contract, including General and Supplementary Conditions and other Division-1 Specification sections, apply to work of this section.

1.2 SUMMARY:

- A. This portion of the specification sets forth the general requirements, including the quality and type of materials required for the installation of all lumber used for wood curbs, nailing strips, miscellaneous blocking material, unexposed fillers, fascia, edging strips, deck replacement, etc
- B. Provide new wood nailers and blocking as needed for roof areas 8 and 9.

1.3 STORAGE:

- A. All material specified herein shall be stored (after delivery to the site) so that it will be fully protected from damage and weather, and shall be piled to prevent warpage. All lumber shall be fully protected to maintain the original required moisture content as specified in item titled "Moisture Content".

1.4 OTHER REQUIREMENTS:

- A. Dimensions indicated on the drawings are nominal dimensions (except where details show actual sizes) and shall be subject to the standard reductions required for surfacing or tolerances permitted by the grading rules. Unless otherwise indicated on drawings, all material shall be S4S (surfaced four sides).

1.5 PROTECTION:

- A. All finished work shall be adequately protected against damage from any source.

1.6 COORDINATION:

- A. Carpenters shall coordinate their work with that of the other trades so that progress continues without interruption.

PART 2 - PRODUCTS

2.1 WOOD - FRAMING AND CURBS:

A. GRADING RULES, GRADES, AND SPECIES

- 1. Lumber: Southern Pine, yellow pine, Douglas fir, spruce, ponderosa pine, larch or Hemlock and shall meet the following minimum grade requirement of construction standard (75% #1 and 25% #2); free from warping and visible decay. Lumber shall be graded according to the standard grading rules of the Southern Pine Inspection Bureau, the West

Coast Lumber Inspection Bureau, or the Western Wood Products Association. **TREATED LUMBER IS NOT TO BE USED.**

B. MOISTURE CONTENT

1. All lumber shall be air-dried or kiln-dried before treatment, so that the moisture content is not more than 19%. After treatment, it shall be kiln-dried at temperatures not exceeding 160 degrees F. (71 degrees C) so that the moisture content is not more than 19% at time of shipment.

C. PLYWOOD:

Grade: CDX or Cyme exterior Grade.

Description: 5/8" thick.

2.2 MECHANICAL FASTENERS:

A. WOOD TO STEEL:

1. Acceptable Manufacturers:
 - a. Stainless Roofgrip screw; plastic disc - Buildex Div. of ITW, Itasca, IL.
 - b. Stainless Dekfast screw: plastic disc - Construction Fasteners, Inc., Wyomissing, PA.
 - c. Fabco Fastening Systems, West Newton, PA: Stainless Insul-Fixx screw with; plastic plate, Stainless Plate-Fixx screw
 - d. Stainless Kwik-Deck; plastic disc - Atlas Bolt & Screw Div., Trans Union Fastener Corp., Ashland, OH.
 - e. Olympic #12-11 Stainless Steel Deck Screw or #14-10 Heavy Duty All Purpose Screw; three inch diameter plastic - Olympic Manufacturing Group, Inc., Agawam, MA.
 - f. Glasfast (plastic disc) - Owens-Corning Fiberglas Corp., Toledo, OH.
 - g. Perma Fastener, stainless, plastic plate - International Permalite, Inc., Oak Brook, IL.
2. Screw Length: Sufficient to engage steel, wood deck 1 inch.

B. WOOD TO WOOD:

1. Type: Stainless Steel, common, annular ring nail. Length: Sufficient to penetrate underlay blocking 1-1/4 inches.
2. Acceptable Manufacturers:
 - a. Hillwood Manufacturing Co., Cleveland, OH.
 - b. Independent Nail, Inc., Bridgewater, MA.
 - c. W.H. Maze Co., Peru, IL.
 - d. National Nail Corp., Grand Rapids, MI.

C. WOOD TO MASONRY:

1. Acceptable Manufacturers:

- a. Tapcon 1/4" diameter, Phillips pan head anchor - Buildex Div. of ITW, Itasca, IL.
- b. Confas - Construction Fasteners, Inc., Wyomissing, PA.
- c. Con-fixx - Fabco Fastening Systems, West Newton, PA.
- d. #14-10 Heavy Duty all Purpose Screw - Olympic Manufacturing Group, Inc., Agawam, MA.
- e. Tru-Fast fastener (stainless steel) - The Tru-Fast Corp., Bryan,

OH.

2. Length: Sufficient to provide 1-1/2 inch embedment.

D. WOOD TO HOLLOW MASONRY:

1. Acceptable Manufacturers:
 - a. Sleeve Anchor by Hilti Fastening Systems, Tulsa, OK.
 - b. Rawly Hollow Masonry Anchor by the Rawlplug Co., Inc., New Rochelle, NY.
2. Length: As recommended by manufacturer

PART 3 - EXECUTION

3.1 CARPENTRY:

- A. At roof edge to receive metal fascia, around all roof top penetration perimeters, and under any flashing component that is to have a roof flange mechanically fastened to roofing substrate; Mechanically attach wood blocking. Blocking thickness: Equal to common 1 x 4", 1 x 6", 2x4", 2x6", 2x8", 2x10", 2x12".
- B. Fasteners shall be installed in two rows staggered. Spacing in any one row shall not exceed 24 inches. Within eight feet of outside corners, spacing shall not exceed twelve inches in any one row.
- C. Where required, offset blocking layers twelve inches, weave corners.
- D. Lumber shall be accurately cut to the work requirements and shall be well fastened.
- E. Bolted fastenings shall have washers of adequate size under both heads and nuts. Nails shall be of correct size and quantity for proper fastening. Oversized nails that will result in splitting shall not be used. All fasteners shall be stainless steel.

END OF SECTION

SECTION 07 22 00

ROOF DECK AND INSULATION

PART 1 – GENERAL

1.1 RELATED DOCUMENTS

- A. Drawings and general provisions of the Contract, including the Conditions of the Contract and Division 01 Specification Sections apply to this section.

1.2 SUMMARY

- A. Section includes roof insulation over the properly prepared deck substrate.
- B. Related Sections:
 - 1. Section 07 05 00 – Common Work Procedures for Thermal and Moisture Protection.
 - 2. Section 07 62 00 – Sheet Metal Flashing and Trim.

1.3 REFERENCES

- A. American Society for Testing and materials (ASTM):
 - 1. ASTM A167 Standard Specification for Stainless and Heat-Resisting Chromium Nickel Steel Plate, Sheet and Strip.
 - 2. ASTM A653 Standard Specification for Steel Sheet, Zinc-Coated (Galvanized) or Zinc-Iron Alloy-Coated (Galvanized) by the Hot-Dip Process.
 - 3. ASTM B29 Standard Specification for Refined Lead.
 - 4. ASTM B32 Standard Specification for Solder Metal.
 - 5. ASTM C165 Standard Test Method for Measuring Compressive Properties of Thermal Insulation.
 - 6. ASTM C208 Standard Specification for Cellulosic Fiber Insulation Board.
 - 7. ASTM C209 Standard Test Method for Cellulosic Fiber Insulating Board.
 - 8. ASTM C272 Standard Test Method for Water Absorption of Core Materials for Structural Sandwich Constructions.
 - 9. ASTM C1396 Standard Specification for Gypsum Wallboard.
 - 10. ASTM C518 Standard Test Method for Steady-State Heat Flux Measurements and Thermal Transmission Properties by Means of the Heat Flow Meter Apparatus.
 - 11. ASTM C578 Standard Specification for Perlite Thermal Insulation Board.
 - 12. ASTM C728 Standard Test Methods for Fire Test of Roof Coverings.
 - 13. ASTM C1289 Standard Specification for Faced Rigid Polyisocyanurate Thermal Insulation.
 - 14. ASTM D5 Standard Test Method for Penetration of Bituminous Materials.
 - 15. ASTM D36 Standard Test Method for Softening Point of Bitumen (Ring and Ball Apparatus).
 - 16. ASTM D312 Standard Specification for Asphalt Used in Roofing.
 - 17. ASTM D412 Standard Test Methods for Vulcanized Rubber and Thermoplastic Rubbers and Thermoplastic Elastomers-Tension.
 - 18. ASTM D1621 Standard Test Method for Compressive Properties of Rigid Cellular Plastics.
 - 19. ASTM D1622 Standard Test Method for Apparent Density of Rigid Cellular Plastics.

- 20. ASTM D1863 Standard Specification for Mineral Aggregate Used on Built-Up Roofs.
 - 21. ASTM D2126 Standard Test Method for Response off Rigid Cellular Plastics to Thermal Humid Aging.
 - 22. ASTM D2178 Standard Specification for Asphalt Glass Felts used in Roofing and Waterproofing.
 - 23. ASTM D4601 Standard Specification for Asphalt-Coated Glass Fiber Base Sheet Used in Roofing.
 - 24. ASTM D5147 Standard Sampling and Testing Modified Bituminous Sheet Material.
- B. Cast Iron Soil Pipe Institute, Washington, D.C. (CISPI)
 - C. Factory Mutual Research (FM):
 - 1. Roof Assembly Classifications.
 - D. National Roofing Contractors Association (NRCA):
 - 1. Roofing and Waterproofing Manual.
 - E. Underwriters Laboratories, Inc. (UL):
 - 1. Fire Hazard Classifications.
 - F. Warnock Hersey (WH):
 - 1. Fire Hazard Classifications.
 - G. Sheet Metal and Air Conditioning Contractors National Association (SMACNA)
 - H. Steel Deck Institute, St. Louis, Missouri (SDI)
 - I. Southern Pine Inspection Bureau, Pensacola, Florida (SPIB)
 - J. Insulation Board, Polyisocyanurate (FS HH-I-1972)
 - K. Insulation Board, Thermal (Fiberboard) (FS LLL-1-535B)

1.4 SUBMITTALS

- A. Submit all non-Garland products upon request.

1.5 QUALITY ASSURANCE

- A. Fire Classification, ASTM E-108.
- B. Manufacturer's Certificate: Certify that roof system furnished is approved by Factory Mutual, Underwriters Laboratories, Warnock Hersey or approved third party testing facility in accordance with ASTM E108, Class A for external fire and meets local or nationally recognized building codes.
- C. Manufacturer's Certificate: Certify that the roof system is adhered properly to meet or exceed the requirements of FM 1-90.
- D. Pre-installation meeting: Refer to Division 07 roofing specifications for pre-installation meeting requirements.

1.6 DELIVERY, STORAGE AND HANDLING

- A. Deliver products to site with seals and labels intact, in manufacturer's original containers, dry and undamaged.
- B. Store all insulation materials in a manner to protect them from the wind, sun and moisture damage prior to and during installation. Any insulation that has been exposed to any moisture shall be removed from the project site.
- C. Keep materials enclosed in a watertight, ventilated enclosure (i.e. tarpaulins).
- D. Store materials off the ground. Any warped, broken or wet insulation boards shall be removed from the site.

PART 2 – PRODUCTS

1.1 PRODUCTS, GENERAL

- A. Refer to Division 01 Section "Common Product Requirements."
- B. Basis of Design: Materials, manufacturer's product designations, and/or manufacturer's names specified herein shall be regarded as the minimum standard of quality required for work of this Section. Comply with all manufacturer and contractor/fabricator quality and performance criteria specified in Part 1.
- C. Substitutions: Products proposed as equal to the products specified in this Section shall be submitted in accordance with Bidding Requirements and Division 01 provisions.
 - 1. Proposals shall be accompanied by a copy of the manufacturer's standard specification section. That specification section shall be signed and sealed by a professional engineer licensed in the state in which the installation is to take place. Substitution requests containing specifications without licensed engineer certification shall be rejected for non-conformance.
 - 2. Include a list of three (3) projects of similar type and extent, located within a one hundred mile radius from the location of the project. In addition, the three projects must be at least five (5) years old and be available for inspection by the Architect, Owner or Owner's Representative.
 - 3. Equivalency of performance criteria, warranty terms, submittal procedures, and contractual terms will constitute the basis of acceptance.
 - 4. The Owner's decision regarding substitutions will be considered final. Unauthorized substitutions will be rejected.

1.2 INSULATION MATERIALS –

- A. Thermal Insulation Properties and Approved Insulation Boards.
 - 1. Rigid Polyisocyanurate Roof Insulation; ASTM C1289:
 - a. Qualities: Rigid, closed cell polyisocyanurate foam core bonded to heavy duty glass fiber mat facers.
 - b. **Northfield Elementary Sections A & C:** 1/8" tapered with and average R-25.
 - c. **Northfield Elementary Sections I:** Minimum base layer 1.5" with a 1/8" tapered plan. An average R- 25 must be achieved.
 - d. **Rushwood Section E:** Minimum base layer 1.5" with a 1/8" tapered plan. An average R- 25 must be achieved

- e. **Rushwood Sections E 1 through E4:** 2 layers of 2.2". **Section D:** Match Existing
 - f. **Northfield Elementary School Sections J & K:** Minimum base layer 1.5" with a 1/8" tapered plan. An average R- 25 must be achieved.
 - g. R-Value: Minimum 5.7 per inch.
 - h. Compliances: UL, WH or FM listed under Roofing Systems Federal Specification HH-I-1972, Class 1.
 - i. Acceptable Products:
 - 1) ENRGY-3; Johns Manville
 - 2) Hytherm; Dow
 - 3) EnergyGuard; GAF
 - 4) Approved Equivalent
2. High Density Fiberboard Roof insulation; ASTM C208
- a. Qualities: Rigid, composed of interlocking fibers factory blended treated with asphalt on the top side.
 - b. Board Size: Four feet by four feet (4' x 4')
 - c. Thickness: Minimum ½".
 - d. Compliances: UL, WH, FM listed under Roofing Systems. Federal Specification LLL-I-535-B.
 - e. Acceptable Manufacturers:
 - 1) Blue Ridge; Celotex
 - 2) Temple Inland
 - 3) GAF Building Materials Corporation
 - 4) FescoBoard; JM
 - 5) Georgia-Pacific
 - 6) Approved Equivalent

1.3 RELATED MATERIALS

- A. Fiber Cant and Tapered Edge Strips: Performed rigid insulation units of sizes/shapes indicated, matching insulation board or of perlite or organic fiberboard, as per the approved manufacturer.
 - 1. Acceptable Manufacturers:
 - a. The Garland Company, Inc.
 - b. Celotex
 - c. Johns Manville
 - d. GAF
 - e. Approved Equivalent
 - 2. Fire Resistant for torch applications:
 - a. Mineral Wool/Roxul Wool
- B. Protection Board: Pre-molded semi-rigid asphalt composition board one half (1/2) inch.
- C. Roof Board Joint Tape: Six (6) inches wide glass fiber mat with adhesive compatible with insulation board facers.
- D. **Northfield Elementary:** Asphalt: ASTM D312, Type III Steep Asphalt.

- E. **Rushwood Elementary: All Areas, Asphalt:** ASTM D312, Type IV Steep Asphalt.
- F. **Northfield Middle School J & K:** Mechanically attach the base layer. Set all additional layers in Asphalt: ASTM D312, Type III Steep Asphalt
- G. **Alternate:** Roof Deck Insulation Adhesive: Dual-component, high rise foam adhesive as recommended by insulation manufacturer and approved by FM indicated ratings.
 - 1. Tensile Strength (ASTM D412).....250 psi
 - 2. Density (ASTM D1875).....8.5 lbs./gal.
 - 3. Viscosity (ASTM D2556).....22,000 to 60,000 cP.
 - 4. 2` Peel Strength (ASTM D903).....17 lb/in.
 - 5. 3` Flexibility (ASTM D816).....Pass @ -70°F
- H. Fasteners: Corrosion resistant screw fastener as recommended by roof membrane manufacturer.
 - 1. Factory Mutual Tested and Approved with three (3) inches coated disc for I-90 rating, length required to penetrate metal deck one inch.

PART 3 – EXECUTION

3.1 EXECUTION, GENERAL

- A. Comply with requirements of Division 01 Section “Common Execution Requirements.”

3.2 INSPECTOR OF SURFACES

- A. Roofing contractor shall be responsible for preparing an adequate substrate to receive insulation.
 - 1. Verify that work which penetrates roof deck has been completed.
 - 2. Verify that wood nailers are properly and securely installed.
 - 3. Examine surfaces for defects, rough spots, ridges, depressions, foreign material, moisture, and unevenness.
 - 4. Do not proceed until defects are corrected.
 - 5. Do not apply insulation until substrate is sufficiently dry.
 - 6. Broom clean substrate immediately prior to application.
 - 7. Use additional insulation to fill depressions and low spots that would otherwise cause ponding water.
 - 8. Verify that temporary roof has been completed.

3.3 INSTALLATION

- A. Attachment with Mechanical Fasteners
 - 1. Approved insulation board shall be fully attached to the deck with an approved mechanical fastening system. As a minimum, the amount of fasteners shall be in accordance with manufacturer’s recommendation for FM I-90 system. Otherwise, a minimum of one fastener per two square feet shall be installed.
 - a. **Zone 1: 11 fasteners per 4' x 8' board**
 - b. **Zone 2: 16 fasteners per 4' x 8' board**
 - c. **Zone 3: 22 fasteners per 4' x 8' board**

2. **Tectum Deck Areas: Type II Base Sheet, With approved FM Approved 1.7" Base Sheet Fasteners or Oly Lock 1.8 attached 9" O.C. minimum.**
 3. Filler pieces of insulation require at least two fasteners per piece if size of insulation is less than four square feet.
 4. Spacing pattern of fasteners shall be as per manufacturer's recommendations to meet the FM requirements. Placement of any fastener from edge of insulation board shall be a minimum of three inches, and a maximum of six (6) inches.
 5. Minimum penetration into deck shall be as recommended by the fastener manufacturer. There is a one (1) inch minimum for metal, wood and structural concrete decks where not specified by the manufacturer. For gypsum and cement-wood fiber decks, penetration shall be determined from pull-out test results with a minimum penetration of one and one-half (1 ½) inches.
 6. Gypsum and cementitious wood fiber decks: Where the roof deck is visible from the building interior, the contractor shall ensure no penetration of fasteners through underside of the deck. Any holes or spalling caused by fastener installation shall be repaired by the roofing contractor. Where the new roof system thickness exceeds an amount so that a minimum of 1 ½ of penetration cannot be achieved with an Olympic TB Fastener, or approved equivalent, then (and only then) toggle bolts may be used to secure installation to the deck.
 7. Tape joints of insulation as per manufacturer's requirements.
- B. Attachment with Hot Bitumen
1. Over the entire deck surface, prime concrete surfaces with asphalt primer at the rate of 1 (one) gallon per one hundred (100) square feet.
 2. Embed one layer of rigid insulation board in solid moppings of hot asphalt at the rate and temperature recommended by insulation manufacturer. Stagger end joints of boards so all open joints will be eliminated. Walk in each piece of insulation and leave boards completely adhered to deck. Each insulation board shall be butt firmly against adjoining panels. All open joints shall be eliminated.
 3. Embed second layer of insulation board in solid moppings of hot asphalt after first layer has been attached as recommended by insulation manufacturer. Stagger end joints of boards so all open joints will be eliminated. Walk in each piece of insulation and leave boards completely adhered to base felt or deck. Each insulation board shall be butt firmly against adjoining panels. All open joints shall be eliminated.
 4. Approved insulation shall be tapered around roof drains and scuppers. Tapered insulation sump shall start with a thickness of one-half at drain bowl to the specified dimension of three feet from the center line of the drain. Install tapered insulation sump in such a way to provide proper slope for runoff. Shape insulation with tool as required so completed surface is smooth and flush with ring of drain. Under no circumstances will the membrane be left unsupported in an area greater than one quarter (1/4) inch. Install recovery board over tapered insulation sump as required.
 5. Approved recovery board one half (1/2) inch thickness shall be installed over base tapered insulation using hot asphalt at the rate of approximately thirty three (33) pounds per square.
 6. All boards shall be cut and fitted where the roof deck intersects a vertical surface. The boards shall be cut to fit a minimum of one quarter (1/4) inch away from the vertical surface.
 7. Install no more insulation at one time than can be roofed on the same day.

8. Install temporary water cut-offs at completion of each day's work and remove upon resumption of work.
 9. Cant Strips/Tapered Edge Strips: Install preformed forty five (45) degree cant strip at junctures of vertical surfaces. Provide preformed, tapered edge strips at perimeter of edges of roof that do not terminate at vertical surfaces and/or indicated on the drawings.
 10. Tape joints of insulation as per manufacturer's requirements.
- C. Attachment with Insulation Adhesive Approved by Factory Mutual (FM).
1. Ensure all surfaces are clean, dry, free of dirt, debris, oils, loose ore embedded gravel, unadhered coatings, deteriorated membrane and other contaminants that may inhibit adhesion.
 2. Apply insulation adhesive directly to the substrate using a ribbon pattern with one quarter to one half (1/4-1/2) inch wide beads 12 inches o.c., using either the manual applicator or an automatic applicator, at a rate of one (1) gallon per one hundred (150) square feet per cartridge.
 - a. **Zone 1: insulation ribbons 12" O.C. Max 4' x 8' board**
 - b. **Zone 2: insulation ribbons 12" O.C. Max 4' x 8' board**
 - c. **Zone 3: insulation ribbons 12" O.C. Max 4' x 8' board**
 3. Immediately place insulation boards into wet adhesive. Do not slide boards into place. Do not allow the adhesive to skin over before installing insulation boards.
 4. Briefly step each board into place to ensure contact with the adhesive. Substrates with irregular surfaces may prevent the insulation board from making positive contact with the adhesive. Relief cuts or temporary weights may be required to ensure proper contact.
 5. All boards shall be cut and fitted where the roof deck intersects a vertical surface. The boards shall be cut to fit a minimum of one quarter (1/4) inch away from the vertical surface.
 6. Tape joints of insulation as per manufacturer's requirements.

3.4 CLEANING

- A. Remove debris and cartons from roof deck. Leave insulation clean and dry, ready to receive roofing membrane.

3.5 CONSTRUCTION WASTE MANAGEMENT

- A. Remove and properly dispose of waste products generated during installation. Comply with requirements of authorities having jurisdiction.

END OF SECTION

SECTION 075500
MODIFIED BITUMINOUS MEMBRANE ROOFING

PART 1 GENERAL

1.1 SECTION INCLUDES

- A. Hot Applied 2-Ply Asphalt Roofing
- B. Cold Applied 2-Ply Asphalt Roofing
- C. Accessories.
- D. Edge Treatment and Roof Penetration Flashings.
- E. All provide sections.

1.2 DESIGN / PERFORMANCE REQUIREMENTS

- A. Perform work in accordance with all federal, state and local codes.
- B. Exterior Fire Test Exposure: Roof system shall achieve a UL, FM or WH Class rating for roof slopes indicated on the Drawings as follows:
 - 1. Factory Mutual Class A Rating.
 - 2. Underwriters Laboratory Class A Rating.
 - 3. Warnock Hersey Class A Rating.
- C. Design Requirements:
 - 1. Uniform Wind Uplift Load Capacity
 - a. Installed roof system shall withstand negative (uplift) design wind loading pressures complying with the roof system manufacturer's wind uplift requirements.

1.3 SUBMITTALS

- A. Submit all non-Garland products upon request.

1.4 QUALITY ASSURANCE

- A. Perform Work in accordance with NRCA Roofing and Waterproofing Manual.
- B. Manufacturer Qualifications: Company specializing in manufacturing products specified with documented ISO 9001 certification and minimum of twelve years of documented experience and must not have been in Chapter 11 bankruptcy during the last five years.
- C. Installer Qualifications: Company specializing in performing Work of this section with minimum five years documented experience and a certified Pre-Approved Garland Contractor.
- D. Installer's Field Supervision: Maintain a full-time Supervisor/Foreman on job site during all phases of roofing work while roofing work is in progress.
- E. Product Certification: Provide manufacturer's certification that materials are manufactured in the United States and conform to requirements specified herein, are chemically and physically compatible with each other, and are suitable for inclusion within the total roof system specified herein.

- F. Source Limitations: Obtain all components of roof system from a single manufacturer. Secondary products that are required shall be recommended and approved in writing by the roofing system Manufacturer. Upon request of the Architect or Owner, submit Manufacturer's written approval of secondary components in list form, signed by an authorized agent of the Manufacturer.

1.5 DISCLOSURE OF MATERIALS AND SUBSTITUTIONS

- A. The materials outlined herein are the type of materials that should be used in this project. When a particular make or trade name is specified, it shall be indicative of the minimum standard required. The bidder must disclose in his/her bid package the manufacturer that is intended to be used on this Project if other than the Basis of Design manufacturer. If no manufacturer is listed, the bidder's bid is accepted only with the use of the Basis of Design manufacturer and the bidder must use the Basis of Design manufacturer.
- B. Bidder will not be allowed to change materials after the bid opening date.
- C. If an alternate material is bid, the material must be equal or exceed the specifications, and submitted by the bidding Roofing Contractor to the Architect for approval and include the following:
 - 1. Written application with explanation of why it should be considered.
 - 2. Material product data sheets.
 - 3. A certificate from an accredited testing laboratory comparing the physical and performance attributes of the proposed material with those materials denoted as pre-approved systems or the characteristics noted in the material specification section, including but not limited to the following:
 - 4. Modified roofing membrane(s) and flashings substantiating Flexibility, Tensile Strength and Tear Strength. Test results must be dated, notarized and be on testing laboratory stationary. Testing for SBS membrane must follow standard ASTM D 5147 test methods. Testing shall be performed at 77°F. Tests at 0°F shall not be considered.
 - 5. A list of at least five (5) jobs where the proposed alternate material was used under similar conditions. These jobs shall be located within fifty (50) miles of the job site. Each job must be at least five (5) years old, and each must be available for inspection by the Architect.
 - 6. The manufacturer must have a current ratio of 6:1 (current assets to current liabilities) and demonstrate such with an **audited** financial statement supported by an affidavit from a third party. Manufacturer must not have been in Chapter 11 bankruptcy during the last five (5) years. The manufacturer must also have current ISO 9001:2000 certification for the manufacturing of the products to be utilized on this project.
 - 7. A sample warranty by the manufacturer of the modified bitumen membrane roofing system. The manufacturer must be the organization that physically manufactures and guarantees the modified roofing membrane.
 - 8. All products must be in accordance with the Health, Safety and Environmental Control (H, S & E) Regulations, e.g., No asbestos materials, no harmful solvent release materials, etc.
 - 9. The Factory Mutual Roof Nav Assembly for the requested system meeting or exceeding all aspects of the specifications.

- D. In making a request for submission, Bidder/Contractor represents:
1. He/she has personally investigated the proposed product or method, and determined that it is equal or superior in all respects to that specified.
 2. He/she will provide the same guarantee for substitution as for the product and method specified.
 3. He/she will coordinate installation of accepted substitution in work, making such changes as may be required for work to be completed in all respects.
 4. He/she waives all claims for additional cost related to substitution, which consequently become apparent.
 5. Cost data is complete and includes all related cost under his/her contract or other contracts, which may be affected by the substitution.
 6. He will reimburse the Owner for all redesign cost by the Architect for accommodation of the substitute.
 7. The Architect reserves the right to be the final authority on the acceptance or rejection of any or all bids, proposed alternate roofing systems or materials that has met ALL specified requirement criteria.
 8. Alternate material submissions shall be sent to the Architect by the bidding Roofing Contractor. Only substitutes approved in writing by the Architect will be considered.

1.6 PRE-INSTALLATION MEETINGS

- A. Convene minimum two weeks prior to commencing Work of this section.
- B. Review installation procedures and coordination required with related Work.
- C. Inspect and make notes of job conditions prior to installation:
 1. Record minutes of the conference and provide copies to all parties present.
 2. Identify all outstanding issues in writing designating the responsible party for follow-up action and the timetable for completion.
 3. Installation of roofing system shall not begin until all outstanding issues are resolved to the satisfaction of the Architect.

1.7 DELIVERY, STORAGE, AND HANDLING

- A. Deliver and store products in manufacturer's unopened packaging with labels intact until ready for installation.
- B. Store all roofing materials in a dry place, on pallets or raised platforms, out of direct exposure to the elements until time of application. Store materials at least 4 inches above ground level and covered with "breathable" tarpaulins.
- C. Stored in accordance with the instructions of the manufacturer prior to their application or installation. Store roll goods on end on a clean flat surface except store KEE-Stone FB 60 rolls flat on a clean flat surface. No wet or damaged materials will be used in the application.
- D. Store at room temperature wherever possible, until immediately prior to installing the roll. During winter, store materials in a heated location with a 50 degree F (10 degree C) minimum temperature, removed only as needed for immediate use. Keep materials away from open flame or welding sparks.

- E. Avoid stockpiling of materials on roofs without first obtaining acceptance from the Architect/Engineer.
- F. Adhesive storage shall be between the range of above 50 degree F (10 degree C) and below 80 degree F (27 degree C). Area of storage shall be constructed for flammable storage.

1.8 COORDINATION

- A. Coordinate Work with installing associated metal flashings as work of this section proceeds.

1.9 PROJECT CONDITIONS

- A. Maintain environmental conditions (temperature, humidity, and ventilation) within limits recommended by manufacturer for optimum results. Do not install products under environmental conditions outside manufacturer's absolute limits.

1.10 WARRANTY

- A. Upon completion of the work, provide the Manufacturer's written and signed NDL Warranty, warranting that, if a leak develops in the roof during the term of this warranty, due either to defective material or defective workmanship by the installing contractor, the manufacturer shall provide the Owner, at the Manufacturer's expense, with the labor and material necessary to return the defective area to a watertight condition. The metal wall panels and edge metal shall be provided by the same manufacturer.
 - 1. Warranty Period:
 - a. 30 years from date of acceptance.
 - b. 90 MPH
- B. Installer is to guarantee all work against defects in materials and workmanship for a period indicated following final acceptance of the Work.
 - 1. Warranty Period:
 - a. 2 years from date of acceptance.

1.11 MANUFACTURER'S INSPECTIONS

- A. Provide daily job site inspections **with reports to the owner and all other applicable parties**. The reports will include pictures of the days progress made by the contractor and a detailed written report as to the work performed that day.
- C. The roofing manufacturer will provide an annual inspection of the roof system with a detailed report outlining the inspection. The report will notify the owner of any routine housekeeping such as cleaning of the drains, storm damage, etc.
- D. The architect has the right to hire a third-party inspector if the inspection requirements are not met. The contractor will be back charged for this service at the rate of \$500 per inspection.
- E. The roofing manufacturer will provide an annual inspection of the roof system with a detailed report outlining the inspection. The report will notify the owner of any routine housekeeping such as cleaning of the drains, storm damage, etc. There is to be no cost associated and it is to take place for the life of the warranty.

PART 2 PRODUCTS

2.1 MANUFACTURERS

- A. Acceptable Manufacturer: Garland Company, Inc. (The); 3800 E. 91st St., Cleveland, OH 44105. ASD. Toll Free: 800-321-9336. Phone: 216-641-7500. Fax: 216-641-0633. Web Site: www.garlandco.com.
- B. Or Approved Equal Per the Specification Requirements
- C. The Products specified are intended and the Standard of Quality for the products required for this project. If other products are proposed the bidder must disclose in the bid the manufacturer and the products that they intend to use on the Project. If no manufacturer and products are listed, the bid may be accepted only with the use of products specified.
 - 1. Bidder will not be allowed to change materials after the bid opening date.
 - 2. If alternate products are included in the bid, the products must be equal to or exceed the products specified. Supporting technical data shall be submitted to the Architect/ Owner for approval prior to acceptance.
 - 3. In making a request for substitution, the Bidder/Roofing Contractor represents that it has:
 - a. Personally investigated the proposed product or method, and determined that it is equal or superior in all respects to that specified.
 - b. Will provide the same guarantee for substitution as for the product and method specified.
 - c. Will coordinate installation of accepted substitution in work, making such changes as may be required for work to be completed in all respects.
 - d. Will waive all claims for additional cost related to substitution, which consequently become apparent.
 - e. Cost data is complete and includes all related cost under his/her contract or other contracts, which may be affected by the substitution.
 - f. Will reimburse the Owner for all redesign cost by the Architect for accommodation of the substitution.
 - 4. Architect/ Owner reserves the right to be the final authority on the acceptance or rejection of any or all bids, proposed alternate roofing systems or materials that has met ALL specified requirement criteria.
 - 5. Failure to submit substitution package, or any portion thereof requested, will result in immediate disqualification and consideration for that particular contractors request for manufacturer substitution.

2.2 ALTERNATE: COLD APPLIED 2-PLY ROOF SYSTEM

- A. Base (Ply) Sheet: One ply bonded to the prepared substrate with Interply Adhesive:
 - 1. Flex Base 80:
- B. Modified Cap (Ply) Sheet: One ply bonded to the prepared substrate with Interply Adhesive:
 - 1. Stress Ply Plus:
- C. Interply Adhesive: (1 and 2)
 - 1. Weatherking :
- D. Flashing Base Ply: One ply bonded to the prepared substrate with Interply Adhesive:
 - 1. Flex Base 80:
- E. Flashing Cap (Ply) Sheet: One ply bonded to the prepared substrate with Interply Adhesive:
 - 1. Stress Ply Plus:
- F. Flashing Ply Adhesive:
 - 1. Flashing Bond:
- G. Surfacing: Requires 30 day wait before applying. Or approval from a Garland Representative.

1. Flood Coat/Aggregate:
 - a. Black-Knight/Black-Stallion Cold:
 - b. #8 Silica, wash grade, pea gravel
2. Surface Coatings:
 - a. Silver-Shield: all exposed membrane
 - b. Silver Flash: 3-coursing of vertical seams.

2.3 **BOTH BASE BID AND ALTERNATE: COLD APPLIED 2-PLY COAL TAR ROOFING – MILLENNIUM (Drain Sumps Only & Nordonía Elementary Section I - Area Between the Drain and the HVAC Unit)**

- A. Base (Ply) Sheet: One ply bonded to the prepared substrate with Interply Adhesive:
 1. Millennium Base:
- B. Modified Cap (Ply) Sheet: One ply bonded to the prepared substrate with interply adhesive.
 1. Millennium FR Mineral:
- C. Interply Adhesive: (1 and 2)
 1. Black-Knight/Black-Stallion Cold:

2.4 **BASE BID: HOT APPLIED 2-PLY ASPHALT ROOFING**

- A. Base (Ply) Sheet: One ply bonded to the prepared substrate with Interply Adhesive:
 1. FlexBase 80:
- B. **Northfield Elementary and Nordonía Middle School** - Interply Adhesive: (1 and 2)
 1. Generic Type III Asphalt:
- C. **Rushwood Elementary** - Interply Adhesive: (1 and 2)
 1. Generic Type IV Asphalt:
- D. Flashing Base Ply: One ply bonded to the prepared substrate with Interply Adhesive: except torch sheet.
 1. Flex Base 80:
- E. Flashing Cap (Ply) Sheet: One ply bonded to the prepared substrate with Interply Adhesive: except torch sheet.
 1. StressPly Plus:
- F. Surfacing:
 1. Aggregate/Flood Coat
 - a. Black-Knight/Black-Stallion Cold:
 2. Surface Coatings (Exposed Flashings & Sloped Areas (**E 1 & E4 of Rushwood**))
 - a. Silver-Shield:

2.5 **ACCESSORIES:**

- A. Roof Insulation: In accordance with Section 07220.
- B. Nails and Fasteners: Non-ferrous metal or galvanized steel, except that hard copper nails shall be used with copper; aluminum or stainless steel nails shall be used with aluminum; and stainless steel nails shall be used with stainless steel, Fasteners shall be self-clinching type of penetrating type as recommended by the deck manufacturer. Fasten nails and fasteners flush-driven through flat metal discs not less than 1 inch (25 mm) diameter. Omit metal discs when one-piece composite nails or fasteners with heads not less than 1 inch (25 mm) diameter are used.

- C. Non-Shrink Grout GarRock: All weather fast setting chemical action concrete material to fill pitch pans.
 - 1. Flexural Strength, ASTM C 78: (modified) 7 days 1100psi
 - 2. High Strength, ASTM C 109: (modified) 24 days 8400lbs (3810kg)
- D. Pitch Pocket Sealer - Seal-Tite: Two part, 100% solids, self-leveling, polyurethane sealant for filling pitch pans as recommended and furnished by the membrane manufacturer.
 - 1. Durometer, ASTM D 2240: 40-50 Shore
 - 2. Elongation, ASTM D 412: 250%
 - 3. Tensile Strength, ASTM D 412: 200 @ 100 mil

2.6 EDGE TREATMENT AND ROOF PENETRATION FLASHINGS

- A. Shop Fabricated Edge Metal: Coping, Edge Metal, and Splice Plate.
 - 1. Zinc-coated steel, ASTM A653, coating designation G-90, in thickness of 22-gauge, chemically treated, commercial or lock-forming quality.
- B. Edge Metal Finishes:
 - 1. Exposed and unexposed surfaces for mill finish flashing, fascia, and coping cap, as shipped from the mill
 - 2. Exposed surfaces for coated panels:
 - a. Steel Finishes: fluorocarbon finish. Epoxy primer baked both sides, .2-.25 mils thickness as approved by finish coat manufacturer. Weathering finish as referred by National Coil Coaters Association (NCCA). Provided with the following properties.
 - 1) Pencil Hardness: ASTM D3363, HB-H / NCCA II-2.
 - 2) Bend: ASTM D-4145, O-T / NCCA II-19
 - 3) Cross-Hatch Adhesion: ASTM D3359, no loss of adhesion
 - 4) Gloss (60 deg. angle): ASTM D523, 25+/-5%
 - 5) Reverse Bend: ASTM D2794, no cracking or loss of adhesion
 - 6) Nominal Thickness: ASTM D1005
 - a) Primer: 0.2 mils
 - b) Topcoat, 0.7 mils min
 - c) Clear Coat (optional, only used with 22 ga. steel) 0.3 mils
 - 7) Color: Provide as specified. (Subject to minimum quantities)
- C. Pitch pans, Rain Collar 22 gauge stainless or 20oz (567gram) copper. All joints should be welded/soldered watertight. See details for design.
- D. Drain Flashings should be 4lb (1.8kg) sheet lead formed and rolled.
- E. Plumbing stacks should be 4lb (1.8kg) sheet lead formed and rolled.
- F. Liquid Flashing - Tuff-Flash: An asphaltic-polyurethane, low odor, liquid flashing material designed for specialized details unable to be waterproofed with typical modified membrane flashings.
 - 1. Tensile Strength, ASTM D 412: 400 psi
 - 2. Elongation, ASTM D 412: 300%
 - 3. Density @77 deg. F 8.5 lb/gal typical
- G. Manufactured Roof Specialties: Shop fabricated copings, fascia, gravel stops, control joints, expansion joints, joint covers and related flashings and trim are specified in Section 07710.
 - 1. Manufactured roof specialties shall conform to the detail requirements of SMACNA "Architectural Sheet Metal Manual" and/or the NRCA "Roofing and Waterproofing Manual" as applicable.

PART 3 EXECUTION

07550-7

Nordonia Hills City School District – Summer Roofing 2023

3.1 EXAMINATION

- A. Do not begin installation until substrates have been properly prepared.
- B. Inspect and approve the deck condition, slopes and fastener backing if applicable, parapet walls, expansion joints, roof drains, stack vents, vent outlets, nailers and surfaces and elements.
- C. Verify that work penetrating the roof deck, or which may otherwise affect the roofing, has been properly completed.
- D. If substrate preparation and other conditions are the responsibility of another installer, notify Architect of unsatisfactory preparation before proceeding.

3.2 PREPARATION

- A. General: Clean surfaces thoroughly prior to installation.
 - 1. Prepare surfaces using the methods recommended by the manufacturer for achieving the best result for the substrate under the project conditions.
 - 2. Fill substrate surface voids that are greater than 1/4 inch wide with an acceptable fill material.
 - 3. Roof surface to receive roofing system shall be smooth, clean, free from loose gravel, dirt and debris, dry and structurally sound.
 - 4. Wherever necessary, all surfaces to receive roofing materials shall be power broom and vacuumed to remove debris and loose matter prior to starting work.
 - 5. Do not apply roofing during inclement weather. Do not apply roofing membrane to damp, frozen, dirty, or dusty surfaces.
 - 6. Fasteners and plates for fastening components mechanically to the substrate shall provide a minimum pull-out capacity of 300 lbs. (136 k) per fastener. Base or ply sheets attached with cap nails require a minimum pullout capacity of 40 lb. per nail.
 - 7. Prime decks where required, in accordance with requirements and recommendations of the primer and deck manufacturer.
- B. Metal Deck: Metal deck shall be installed as specified in Section
 - 1. Fastening of the deck should comply with the anticipated live and dead loads pertaining to the building as well as applicable Code.
 - 2. Steel decks shall be minimum 22-gauge factory galvanized or zinc alloy coated for protection against corrosion.
 - 3. Suitable insulation shall be mechanically attached as recommended by the insulation manufacturer.
 - 4. Decks shall comply with the gauge and span requirements in the current Factory Mutual FM Approval Guide and be installed in accordance with Loss Prevention Data Sheet 1-28 or specific FM approval.
 - 5. When re-roofing over steel decks, surface corrosion shall be removed, and repairs to severely corroded areas made. Loose or inadequately secured decking shall be fastened, and irreparable or otherwise defective decking shall be replaced.
- C. Cementitious Wood Fiber
 - 1. Protect decks from the weather during storage and application. Any wet or deformed decking shall be removed and replaced.
 - 2. Cementitious wood fiber decks shall not be installed over high humidity occupancies.
 - 3. Cementitious wood fiber decks shall have a minimum design load as recommended by the deck manufacturer.
 - 4. Anchor cementitious wood fiber deck panels against uplift and lateral movement.
 - 5. Install deck level. Correct or replace deck with any deflection, irregularities, or otherwise damaged panels.
 - 6. Install a mechanically attached base sheet prior to installation of insulation or roofing

membrane.

3.3 INSTALLATION - GENERAL

- A. Install modified bitumen membranes and flashings in accordance with manufacturer's instructions and with the recommendations provided by the National Roofing Contractors Association's Roofing & Waterproofing Manual, the Asphalt Roofing Manufacturers Association, and applicable codes.
- B. General: Avoid installation of modified bitumen membranes at temperatures lower than 40-45 degrees F. When work at such temperatures unavoidable use the following precautions:
 - 1. Take extra care during cold weather installation and when ambient temperatures are affected by wind or humidity, to ensure adequate bonding is achieved between the surfaces to be joined. Use extra care at material seam welds and where adhesion of the applied product to the appropriately prepared substrate as the substrate can be affected by such temperature constraints as well.
 - 2. Unrolling of cold materials, under low ambient conditions must be avoided to prevent the likelihood of unnecessary stress cracking. Rolls must be at least 40 degrees F at the time of application. If the membrane roll becomes stiff or difficult to install, it must be replaced with roll from a heated storage area.
- C. Commence installation of the roofing system at the lowest point of the roof (or roof area), working up the slope toward the highest point. Lap sheets shingle fashion so as to constantly shed water
- D. All slopes greater than 2:12 require back-nailing to prevent slippage of the ply sheets. Use ring or spiral-shank 1 inch cap nails, or screws and plates at a rate of 1 fastener per ply (including the membrane) at each insulation stop. Place insulation stops at 16 ft o.c. for slopes less than 3:12 and 4 feet o.c. for slopes greater than 3:12. On non-insulated systems, nail each ply directly into the deck at the rate specified above. When slope exceeds 2:12, install all plies parallel to the slope (strapping) to facilitate backnailing. Install 4 additional fasteners at the upper edge of the membrane when strapping the plies.

3.4 INSTALLATION HOT APPLIED ROOF SYSTEM

- A. Base/Felt Ply(s): Install base sheet or felt plies in twenty five (25) lbs (11.3kg) per square of bitumen shingled uniformly to achieve one or more plies over the entire prepared substrate. Shingle in direction of slope of roof to shed water on each area of roof. Do not step on base rolls until asphalt has cooled, fish mouths should be cut and patched.
 - 1. Lap ply sheet ends 8 inches (203 mm). Stagger end laps 2 inches (304mm) minimum.
 - 2. Install base flashing ply to all perimeter and projection details after membrane application.
 - 3. Extend plies 2 inches beyond top edges of cants at wall and projection bases.
 - 4. Install base flashing ply to all perimeter and projection details.
 - 5. Allow the one ply of base sheet to cure at least 30 minutes before installing the modified membrane. However, the modified membrane must be installed the same day as the base plies.
- B. Modified Cap Ply(s): Solidly bond the modified membrane to the base layers with specified material at the rate of 25 to thirty 30 lbs. (11-13kg) per 100 square feet.
 - 1. Roll must push a puddle of hot material in front of it with material slightly visible at all side laps. Use care to eliminate air entrapment under the membrane. Exercise care during application to eliminate air entrapment under the membrane.
 - 2. Apply pressure to all seams to ensure that the laps are solidly bonded to substrate.
 - 3. Install subsequent rolls of modified membrane as above with a minimum of 4 inch (101 mm) side laps and 8 inch (203 mm) end laps. Stagger end laps. Apply membrane in the same direction as the previous layers but stagger the laps so they

- do not coincide with the laps of the base layers.
4. Apply hot material no more than 5 feet (1.5 m) ahead of each roll being embedded.
 5. Extend membrane 2 inches (50 mm) beyond top edge of all cants in full moppings of the specified hot material.
- C. Fibrous Cant Strips: Provide non-combustible perlite or glass fiber cant strips at all wall/curb detail treatments where angle changes are greater than 45 degrees. Cant may be set in approved cold adhesives, hot asphalt or mechanically attached with approved plates and fasteners.
- D. Wood Blocking, Nailers and Cant Strips: Provide wood blocking, nailers and cant strips as specified in Section 06114.
1. Provide nailers at all roof perimeters and penetrations for fastening membrane flashings and sheet metal components.
 2. Wood nailers should match the height of any insulation, providing a smooth and even transition between flashing and insulation areas.
 3. Nailer lengths should be spaced with a minimum 1/8 inch gap for expansion and contraction between each length or change of direction.
 4. Nailers and flashings should be fastened in accordance with Factory Mutual "Loss Prevention Data Sheet 1- 49, Perimeter Flashing" and be designed to be capable of resisting a minimum force of 200 lbs/lineal foot in any direction.
- E. Metal Work: Provide metal flashings, counter flashings, parapet coping caps and thru-wall flashings as specified in Section 07620 or Section 07710. Install in accordance with the SMACNA "Architectural Sheet Metal Manual" or the NRCA Roofing Waterproofing manual.
- F. Termination Bar: Provide a metal termination bar or approved top edge securement at the terminus of all flashing sheets at walls and curbs. Fasten the bar a minimum of 8 inches (203 mm) o/c to achieve constant compression. Provide suitable, sealant at the top edge if required.
- G. Flashing Base Ply: Install flashing sheets by the same application method used for the base ply.
1. Seal curb, wall and parapet flashings with an application of mastic and mesh on a daily basis. Do not permit conditions to exist that will allow moisture to enter behind, around or under the roof or flashing membrane.
 2. Prepare all walls, penetrations, expansion joints and surfaces to be flashed with required primer at the rate of 100 square feet per gallon. Allow primer to dry tack free.
 3. Adhere to the underlying base flashing ply with specified hot material unless otherwise noted in these specifications. Nail off at a minimum of 8 inches (203 mm) o.c. from the finished roof at all vertical surfaces.
 4. Solidly adhere the entire sheet of flashing membrane to the substrate.
 5. Seal all vertical laps of flashing membrane with a three-course application of trowel-grade mastic and mesh.
 6. Coordinate counter flashing, cap flashings, expansion joints, and similar work with modified bitumen roofing work as specified.
 7. Coordinate roof accessories, miscellaneous sheet metal accessory items, including piping vents and other devices with the roofing system work.
- H. Flood Coat/Aggregate:
1. Install after cap sheets and modified flashing, tests, repairs and corrective actions have been completed and approved.
 2. Apply flood coat materials in the quantities recommended by the manufacturer.
 3. Uniformly embed aggregate in the flood coat of cold adhesive at a rate recommended by the manufacturer.
 4. Aggregate must be dry and placed in a manner required to form a compact, embedded overlay. To aid in embedment, lightly roll aggregate.

- I. Flashing Cap Ply: Install flashing cap sheets by the same application method used for the cap ply.
 - 1. Seal curb, wall and parapet flashings with an application of mastic and mesh on a daily basis. Do not permit conditions to exist that will allow moisture to enter behind, around or under the roof or flashing membrane.
 - 2. Prepare all walls, penetrations, expansion joints and where shown on the Drawings to be flashed with required primer at the rate of 100 square feet per gallon. Allow primer to dry tack free.
 - 3. Adhere to the underlying base flashing ply with specified flashing ply adhesive unless otherwise specified. Nail off at a minimum of 8 inches (203 mm) o.c. from the finished roof at all vertical surfaces.
 - 4. Coordinate counter flashing, cap flashings, expansion joints and similar work with modified bitumen roofing work as specified.
 - 5. Coordinate roof accessories, miscellaneous sheet metal accessory items with the roofing system work.
 - 6. All stripping shall be installed prior to flashing cap sheet installation.
 - 7. Heat and scrape granules when welding or adhering at cut areas and seams to granular surfaces at all flashings.
 - 8. Secure the top edge of the flashing sheet using a termination bar only when the wall surface above is waterproofed, or nailed 4 inches on center and covered with an acceptable counter flashing.

- J. Surface Coatings: Apply roof coatings in strict conformance with the manufacturer's recommended procedures.

3.5 INSTALLATION COLD APPLIED ROOF SYSTEM

- A. Base Ply: Cut base ply sheets into 18 foot lengths and allow plies to relax before installing. Install base sheet in Interply Adhesive: applied at the rate required by the manufacturer. Shingle base sheets uniformly to achieve one ply throughout over the prepared substrate. Shingle in proper direction to shed water on each large area of roofing.
 - 1. Lap ply sheet ends 8 inches. Stagger end laps 12 inches minimum.
 - 2. Solidly bond to the substrate and adjacent ply with specified cold adhesive at the rate of 2-1/2 gallons per 100 square feet.
 - 3. Roll must push a puddle of adhesive in front of it with adhesive slightly visible at all side laps. Use care to eliminate air entrapment under the membrane.
 - 4. Install subsequent rolls of modified across the roof as above with a minimum of 4 inch side laps and 8 inch staggered end laps. Lay modified membrane in the same direction as the underlayers but the laps shall not coincide with the laps of the base layers.
 - 5. Extend plies 2 inches beyond top edges of cants at wall and projection bases.
 - 6. Install base flashing ply to all perimeter and projection details.
 - 7. Allow the one ply of base sheet to cure at least 30 minutes before installing the modified membrane. However, the modified membrane must be installed the same day as the base plies.

- B. Modified Cap Ply(s): Cut cap ply sheets into 18 foot lengths and allow plies to relax before installing. Install in interplay adhesive applied at the rate required by the manufacturer. Shingle sheets uniformly over the prepared substrate to achieve the number of plies specified. Shingle in proper direction to shed water on each large area of roofing.
 - 1. Lap ply sheet ends 8 inches. Stagger end laps 12 inches minimum.
 - 2. Solidly bond to the base layers with specified cold adhesive at the rate of 2 to 2-1/2 gallons per 100 square feet.
 - 3. Roll must push a puddle of adhesive in front of it with adhesive slightly visible at all side laps. Care should be taken to eliminate air entrapment under the membrane.
 - 4. Install subsequent rolls of modified across the roof as above with a minimum of 4 inch

- side laps and 8 inch staggered end laps. Lay modified membrane in the same direction as the underlayers but the laps shall not coincide with the laps of the base layers.
5. Allow cold adhesive to set for 5 to 10 minutes before installing the top layer of modified membrane.
 6. Extend membrane 2 inches beyond top edge of all cants in full moppings of the cold adhesive as shown on the Drawings.
- C. Fibrous Cant Strips: Provide non-combustible perlite or glass fiber cant strips at all wall/curb detail treatments where angle changes are greater than 45 degrees. Cant may be set in approved cold adhesives, hot asphalt or mechanically attached with approved plates and fasteners.
- D. Wood Blocking, Nailers and Cant Strips: Provide wood blocking, nailers and cant strips as specified in Section 06114.
1. Provide nailers at all roof perimeters and penetrations for fastening membrane flashings and sheet metal components.
 2. Wood nailers should match the height of any insulation, providing a smooth and even transition between flashing and insulation areas.
 3. Nailer lengths should be spaced with a minimum 1/8 inch gap for expansion and contraction between each length or change of direction.
 4. Nailers and flashings should be fastened in accordance with Factory Mutual "Loss Prevention Data Sheet 1- 49, Perimeter Flashing" and be designed to be capable of resisting a minimum force of 200 lbs/lineal foot in any direction.
- E. Metal Work: Provide metal flashings, counter flashings, parapet coping caps and thru-wall flashings as specified in Section 07620 or Section 07710. Install in accordance with the SMACNA "Architectural Sheet Metal Manual" or the NRCA Roofing Waterproofing manual.
- F. Termination Bar: Provide a metal termination bar or approved top edge securement at the terminus of all flashing sheets at walls and curbs. Fasten the bar a minimum of 8 inches (203 mm) o/c to achieve constant compression. Provide suitable, sealant at the top edge if required.
- G. Flashing Base Ply: Install flashing sheets by the same application method used for the base ply.
1. Seal curb, wall and parapet flashings with an application of mastic and mesh on a daily basis. Do not permit conditions to exist that will allow moisture to enter behind, around or under the roof or flashing membrane.
 2. Prepare all walls, penetrations, expansion joints and where shown on the Drawings to be flashed with required primer at the rate of 100 square feet per gallon. Allow primer to dry tack free.
 3. Adhere to the underlying base ply with specified flashing ply adhesive unless otherwise specified. Nail off at a minimum of 8 inches (203 mm) o.c. from the finished roof at all vertical surfaces.
 4. Solidly adhere the entire flashing ply to the substrate. Secure the tops of all flashings that are not run up and over curb through termination bar fastened at 6 inches (152 mm) O.C. and sealed at top.
 5. Seal all vertical laps of flashing ply with a three-course application of trowel-grade mastic and fiberglass mesh.
 6. Coordinate counter flashing, cap flashings, expansion joints and similar work with modified bitumen roofing work as specified.
 7. Coordinate roof accessories, miscellaneous sheet metal accessory items, including piping vents and other devices with the roofing system work.
 8. Secure the top edge of the flashing sheet using a termination bar only when the wall surface above is waterproofed, or nailed 4 inches on center and covered with an acceptable counter flashing.

- H. Flood Coat/Aggregate:
 1. Install after cap sheets and modified flashing, tests, repairs and corrective actions have been completed and approved.
 2. Apply flood coat materials in the quantities recommended by the manufacturer.
 3. Uniformly embed aggregate in the flood coat of cold adhesive at a rate recommended by the manufacturer.
 4. Aggregate must be dry and placed in a manner required to form a compact, embedded overlay. To aid in embedment, lightly roll aggregate.

- I. Flashing Cap Ply:
 1. Seal curb, wall and parapet flashings with an application of mastic and mesh on a daily basis. Do not permit conditions to exist that will allow moisture to enter behind, around or under the roof or flashing membrane.
 2. Prepare all walls, penetrations, expansion joints and where shown on the Drawings to be flashed with required primer at the rate of 100 square feet per gallon. Allow primer to dry tack free.
 3. Adhere to the underlying base flashing ply with specified flashing ply adhesive unless otherwise specified. Nail off at a minimum of 8 inches (203 mm) o.c. from the finished roof at all vertical surfaces.
 4. Coordinate counter flashing, cap flashings, expansion joints and similar work with modified bitumen roofing work as specified.
 5. Coordinate roof accessories, miscellaneous sheet metal accessory items with the roofing system work.
 6. All stripping shall be installed prior to flashing cap sheet installation.
 7. Heat and scrape granules when welding or adhering at cut areas and seams to granular surfaces at all flashings.
 8. Secure the top edge of the flashing sheet using a termination bar only when the wall surface above is waterproofed, or nailed 4 inches on center and covered with an acceptable counter flashing.

- J. Surface Coatings: Apply roof coatings in strict conformance with the manufacturer's recommended procedures.

- K. Roof Walkways: Provide walkways in areas indicated on the Drawings.

3.6 INSTALLATION EDGE TREATMENT AND ROOF PENETRATION FLASHING

- A. Metal Edge:
 1. Inspect the nailers to assure proper attachment and configuration.
 2. Run one ply over the edge. Assure coverage of all wood nailers. Fasten plies with ring shank nails at 8 inches (203 mm) o.c.
 3. Install continuous cleat and fasten at 6 inches (152 mm) o.c.
 4. Install new metal edge hooked to continuous cleat and set in bed of roof cement. Fasten flange to wood nailers every 3 inches (76 mm) o.c. staggered.
 5. Prime metal edge at a rate of 100 square feet per gallon and allow to dry. Do not prime for Green-Lock System lightly sand metal to improve bond.
 6. Strip in flange with base flashing ply covering entire flange in bitumen with 6 inches (152 mm) on to the field of roof. Assure ply laps do not coincide with metal laps.
 7. Install a second ply of modified flashing ply in bitumen over the base flashing ply, 9 inches (228 mm) on to the field of the roof. Seal outside edge with rubberized cement.

- B. Raised Metal Edge:
 1. Inspect the nailer to assure proper attachment and configuration.
 2. Run one ply over the edge. Assure coverage of all wood nailers. Fasten plies with ring shank nails at 8 inches (203 mm) o.c.
 3. Install continuous cleat and fasten at 6 inches (152 mm) o.c.
 4. Install new metal edge hooked to continuous cleat and set in bed of roof cement.

Fasten flange to wood nailer every 3 inches (76 mm) o.c. staggered.

5. Prime metal edge at a rate of 100 square feet per gallon and allow to dry. Do not prime for Green-Lock System lightly sand metal to improve bond.
6. Strip in flange with base flashing ply covering entire flange in bitumen with 6 inches (152 mm) on to the field of roof. Assure ply laps do not coincide with metal laps.
7. Install a second ply of modified flashing ply in bitumen over the base flashing ply, 9 inches (228 mm) on to the field of the roof.

C. Coping Cap:

1. Minimum flashing height is 8 inches (203 mm) above finished roof height. Maximum flashing height is 24 inches (609 mm). Prime vertical wall at a rate of 100 square feet per gallon and allow to dry.
2. Set cant in bitumen. Run all field plies over cant a minimum of 2 inches (50 mm).
3. Attach tapered board to top of wall.
4. Install base flashing ply covering entire wall and wrapped over top of wall and down face with 6 inches (152 mm) on to field of roof and set in cold asphalt. Nail membrane at 8 inches (203 mm) o.c.
5. Install a second ply of modified flashing ply in bitumen over the base flashing ply, 9 inches (228 mm) on to the field of the roof. Apply a three-course application of mastic and mesh at all seams and allow to cure and aluminize.
6. Install continuous cleat and fasten at 6 inches (152 mm) o.c. to outside wall.
7. Install new metal coping cap hooked to continuous cleat.
8. Fasten inside cap 24 inches (609 mm) o.c. with approved fasteners and neoprene washers through slotted holes, which allow for expansion and contraction.

D. Surface Mounted Counterflashing:

1. Minimum flashing height is 8 inches (203 mm) above finished roof height. Maximum flashing height is 24 inches (609 mm). Prime vertical wall at a rate of 100 square feet per gallon and allow to dry.
2. Set cant in bitumen. Run all field plies over cant a minimum of 2 inches (50 mm).
3. Install base flashing ply covering wall set in bitumen with 6 inches (152 mm) on to field of the roof.
4. Install a second ply of modified flashing ply in bitumen over the base flashing ply, 9 inches (228 mm) on to the field of the roof. Apply a three-course application of mastic and mesh at all vertical seams and allow to cure and aluminize.
5. Apply butyl tape to wall behind flashing. Secure termination bar through flashing, butyl tape and into wall. Alternatively use caulk to replace the butyl tape.
6. Secure counterflashing set on butyl tape above flashing at 8 inches (203 mm) o.c. and caulk top of counterflashing.

E. Manufactured Wall Panel W/Modified Roof/Flashing (Slip Flashing):

1. Minimum flashing height is 8 inches (203 mm) above finished roof height. Prime vertical wall at a rate of 100 square feet per gallon and allow to dry.
2. Set cant in bitumen. Run all plies over cant a minimum of 2 inches (50 mm).
3. Install base flashing ply covering wall with 6 inches (152 mm) on to field of the roof.
4. Install a second ply of modified flashing ply in bitumen over the base flashing ply, 9 inches (228 mm) on to the field of the roof. Apply a three-course application of mastic and mesh at all vertical seams and allow to cure and aluminize.
5. Install manufacturer's standard hat channel into the top of the modified membrane to act as a termination bar.
6. Install hat channels vertically spaced up the wall and fastened in accordance with the wind uplift calculation requirements.
7. Install the uppermost hat channel at the bottom edge of the coping cap. Insert rigid insulation between the hat channels. Place manufacturer's standard seam tape on top of all hat channels.
8. Fasten the first manufactured wall panel vertically plumb and fasten every) inches

- (152 mm) o.c.
9. Install adjoining panels by engaging the opposing interlocking seam and fastening as described above.
 10. Complete inside and outside corners by installing pre-fabricated corners or job site braking a full width panel to accommodate the corner, so that the sides engage the lock of the panels to the corner areas.
 11. Trim excess seam tape and seam raw edges with manufacturer's recommended sealant.
 12. Fasten slip flashing to existing coping cap with a waterproof rivet every 24 inches (609 mm) o.c. to act as a counterflashing over the manufactured wall panel.
- F. Manufactured Wall Panel W/Modified Bitumen Roof/Flashing:
1. Minimum flashing height is 8 inches (203 mm) above finished roof height. Prime vertical wall at a rate of 100 square feet per gallon and allow to dry.
 2. Set cant in bitumen. Run all plies over cant a minimum of 2 inches (50 mm).
 3. Install base flashing ply covering wall with 6 inches (152 mm) on to field of the roof.
 4. Install a second ply of modified flashing ply in bitumen over the base flashing ply, 9 inches (228 mm) on to the field of the roof. Apply a three-course application of mastic and mesh at all vertical seams and allow to cure and aluminize.
 5. Install manufacturer's standard hat channel into the top of the modified membrane to act as a termination bar.
 6. Install hat channels vertically spaced up the wall and fastened in accordance with the wind uplift calculation requirements.
 7. Install the uppermost hat channel at the bottom edge of the coping cap. Insert rigid insulation between the hat channels. Apply manufacturer' standard seam tape on top of all hat channels.
 8. Fasten the first manufactured wall panel vertically plumb and fasten every 6 inches (152 mm) o.c.
 9. Install adjoining panels by engaging the opposing interlocking seam and fastening as described above.
 10. Complete inside and outside corners by installing pre-fabricated corners or job site braking a full width panel to accommodate the corner so that the sides engage the lock of the panels to the corner areas.
 11. Trim excess seam tape and seam raw edges with manufacturer's recommended sealant.
- G. Area Divider:
1. Minimum curb height is 8 inches (203 mm) above finished roof height. Prime vertical curb at a rate of 100 square feet per gallon and allow to dry.
 2. Set cant in bitumen. Run all field plies over cant a minimum of 2 inches (50 mm).
 3. Install base flashing ply covering curb set in bitumen with 6 inches (152 mm) on to field of the roof.
 4. Install a second ply of modified flashing ply in bitumen over the base flashing ply, 9 inches (228 mm) on to the field of the roof. Attach top of membrane to top of curb and nail at 8 inches (203 mm) o.c. Apply a three-course application of mastic and mesh at all vertical seams and allow to cure and aluminize.
 5. Install pre-manufactured cover. Fasten sides at 24 inches (609 mm) o.c. with fasteners and neoprene washers through slotted holes. Furnish all joint cover laps with butyl tape between metal covers.
- H. Equipment Support:
1. Minimum curb height is 8 inches (203 mm) above finished roof height. Prime vertical at a rate of 100 square feet per gallon and allow to dry.
 2. Set cant in bitumen. Run all field plies over cant a minimum of 2 inches (50 mm).
 3. Install base flashing ply covering curb set in bitumen with 6 inches (152 mm) on to field of the roof.

4. Install a second ply of modified flashing ply in bitumen over the base flashing ply, 9 inches (228 mm) on to the field of the roof. Attach top of membrane to top of curb and nail at 8 inches (203 mm) o.c. Apply a three-course application of mastic and mesh at all vertical seams and allow to cure and aluminize.
 5. Install pre-manufactured cover. Fasten sides at 24 inches (609 mm) o.c. with fasteners and neoprene washers. Furnish all joint cover laps with butyl tape between metal covers.
 6. Set equipment on neoprene pad and fasten as required by equipment manufacturer.
- I. Pre-manufactured Curb For Equipment Support:
1. Minimum curb height is 8 inches (203 mm) above finished roof height. Prime vertical at a rate of 100 square feet per gallon and allow to dry.
 2. Run all field plies over cant of the pre-manufactured equipment support a minimum of 2 inches.
 3. Install base flashing ply covering pre-manufactured curb with 6 inches (152 mm) on to field of the roof.
 4. Install a second ply of modified flashing ply installed over the base flashing ply, 9 inches (228 mm) on to field of the roof. Attach top of membrane to top of wood curb and nail at 8 inches (203 mm) o.c. Apply a three-course application of mastic and mesh at all vertical seams and allow to cure and aluminize.
 5. Install pre-manufactured cover. Fasten sides at 24 inches (609 mm) o.c. with fasteners and neoprene washers. Furnish all joint cover laps with butyl tape between metal covers.
 6. Set equipment on neoprene pad and fasten as required by equipment manufacturer.
- J. Exhaust Fan:
1. Minimum curb height is 8 inches (203 mm) above finished roof height. Prime vertical at a rate of 100 square feet per gallon and allow to dry.
 2. Set cant in bitumen. Run all plies over cant a minimum of 2 inches (50 mm).
 3. Install base flashing ply covering curb with 6 inches (152 mm) on to field of the roof.
 4. Install a second ply of modified flashing ply installed over the base flashing ply, 9 inches (228 mm) on to field of the roof. Attach top of membrane to top of wood curb and nail at 8 inches (203 mm) o.c. Apply a three-course application of mastic and mesh at all vertical seams and allow to cure and aluminize.
 5. Install metal exhaust fan over the wood nailers and flashing to act as counterflashing. Fasten per manufacturer's recommendation.
- K. Passive Vent/Air Intake:
1. Minimum curb height is 8 inches (203 mm) above finished roof height. Prime vertical at a rate of 100 square feet per gallon and allow to dry.
 2. Set cant in bitumen. Run all plies over cant a minimum of 2 inches (50 mm).
 3. Install base flashing ply covering curb with 6 inches (152mm) on to the field of the roof.
 4. Install a second ply of modified flashing ply installed over the base flashing ply, 9 inches (228 mm) on to field of the roof. Attach top of membrane to top of wood curb and nail at 8 inches (203 mm) o.c. Apply a three-course application of mastic and mesh at all vertical seams and allow to cure and aluminize.
 5. Install passive vent/air intake over the wood nailers and flashing to act as counterflashing. Fasten per manufacturer's recommendations.
- L. Roof Drain:
1. Plug drain to prevent debris from entering plumbing.
 2. Taper insulation to drain minimum of 24 inches (609 mm) from center of drain.
 3. Run roof system plies over drain. Cut out plies inside drain bowl.
 4. Set lead/copper flashing (30 inch square minimum) in 1/4 inch bed of mastic. Run lead/copper into drain a minimum of 2 inches (50 mm). Prime lead/copper at a rate of

100 square feet per gallon and allow to dry.

5. Install base flashing ply (40 inch square minimum) in bitumen.
6. Install modified membrane (48 inch square minimum) in bitumen.
7. Install clamping ring and assure that all plies are under the clamping ring.
8. Remove drain plug and install strainer.

M. Plumbing Stack:

1. Minimum stack height is 12 inches (609 mm).
2. Run roof system over the entire surface of the roof. Seal the base of the stack with elastomeric sealant.
3. Prime flange of new sleeve. Install properly sized sleeves set in 1/4 inch (6 mm) bed of roof cement.
4. Install base flashing ply in bitumen.
5. Install membrane in bitumen.
6. Caulk the intersection of the membrane with elastomeric sealant.
7. Turn sleeve a minimum of 1 inch (25 mm) down inside of stack.

N. Heat Stack:

1. Minimum stack height is 12 inches (609 mm).
2. Run roof system over the entire surface of the roof. Seal the base of the stack with elastomeric sealant.
3. Prime flange of new sleeve. Install properly sized sleeves set in 1/4 inch (6 mm) bed of roof cement.
4. Install base flashing ply in bitumen.
5. Install modified membrane in bitumen.
6. Caulk the intersection of the membrane with elastomeric sealant.
7. Install new collar over cape. Weld collar or install stainless steel draw brand.

O. Pitch Pocket Umbrella:

1. Run all plies up to the penetration.
2. Place the pitch pocket over the penetration and prime all flanges.
3. Strip in flange of pitch pocket with one ply of base flashing ply. Extend 6 inches (152 mm) onto field of roof.
4. Install second layer of modified membrane extending 9 inches (228 mm) onto field of the roof.
5. Fill pitch pocket half full with non-shrink grout. Let this cure and top off with pourable sealant.
6. Caulk joint between roof system and pitch pocket with roof cement.
7. Place a watershedding type bonnet over the top of the pitch pocket and clamp the top with a drawband collar. Caulk the upper edge of the band with an elastomeric sealant.

P. Liquid Flashing:

1. Mask target area on roof membrane with tape.
2. Clean all non-porous areas with isopropyl alcohol.
3. Apply 32 wet mil base coat of liquid flashing over masked area.
4. Embed polyester reinforcement fabric into the base coat of the liquid flashing.
5. Apply 48-64 wet mil top coat of the liquid flashing material over the fabric extending 2 inches (51 mm) past the scrim in all directions.
6. Apply minerals immediately or allow the liquid flashing material to cure 15-30 days and then install reflective coating.

3.7 CLEANING

- A. Clean-up and remove daily from the site all wrappings, empty containers, paper, loose particles and other debris resulting from these operations.
- B. Remove asphalt markings from finished surfaces.

- C. Repair or replace defaced or disfigured finishes caused by Work of this section.

3.8 PROTECTION

- A. Provide traffic ways, erect barriers, fences, guards, rails, enclosures, chutes and the like to protect personnel, roofs and structures, vehicles and utilities.
- B. Protect exposed surfaces of finished walls with tarps to prevent damage.
- C. Plywood for traffic ways required for material movement over existing roofs shall be not less than 5/8 inch (16 mm) thick.
- D. In addition to the plywood listed above, an underlayment of minimum 1/2 inch (13 mm) recover board is required on new roofing.
- E. Special permission shall be obtained from the Manufacturer before any traffic shall be permitted over new roofing.

3.9 FIELD QUALITY CONTROL

- A. Inspection: Provide manufacturer's field observations at start-up and at intervals of approximately 30 percent, 60 percent and 90 percent completion. Provide a final inspection upon completion of the Work.
 - 1. Warranty shall be issued upon manufacturer's acceptance of the installation.
 - 2. Field observations shall be performed by a Sales Representative employed full-time by the manufacturer and whose primary job description is to assist, inspect and approve membrane installations for the manufacturer.
 - 3. Provide observation reports from the Sales Representative indicating procedures followed, weather conditions and any discrepancies found during inspection.
 - 4. Provide a final report from the Sales Representative, certifying that the roofing system has been satisfactorily installed according to the project specifications, approved details and good general roofing practice.

3.10 SCHEDULES

- A. Base (Ply) Sheet:
 - 1. FlexBase 80: 80 mil SBS (Styrene-Butadiene-Styrene) rubber modified roofing base sheet reinforced with a dual fiberglass reinforced scrim, performance requirements according to ASTM D 5147.
 - a. Tensile Strength, ASTM D 5147
 - 1) 2 in/min. @ 73.4 +/- 3.6 deg. F MD 225 lbf/in XD 225 lbf/in
 - 2) 50 mm/min. @ 23 +/- 2 deg. C MD 39.0 kN/m XD 39 kN/m
 - b. Tear Strength, ASTM D 5147
 - 1) 2 in/min. @ 73.4 +/- 3.6 deg. F MD 300 lbf XD 300 lbf
 - 2) 50 mm/min. @ 23 +/- 2 deg. C MD 1335 N XD 1335 N
 - c. Elongation at Maximum Tensile, ASTM D 5147
 - 1) 2 in/min. @ 73.4 +/- 3.6 deg. F MD 7% XD 7%
 - 2) 50 mm/min. @ 23 +/- 2 deg. C MD 7% XD 7%
 - d. Low Temperature Flexibility, ASTM D 5147, Passes -30 deg. F (-34.4 deg. C)
- B. Modified Cap (Ply) Sheet:
 - 1. StressPly Plus: 105 mil SBS (Styrene-Butadiene-Styrene) rubber modified roofing membrane incorporating recycled rubber and reinforced with a fiberglass and polyester composite scrim. ASTM D 6162, Type III Grade S
 - a. Tensile Strength, ASTM D 5147
 - 1) 2 in/min. @ 73.4 +/- 3.6 deg. F MD 310 lbf/in XD 310 lbf/in
 - 2) 50 mm/min. @ 23 +/- 2 deg. C MD 54.25 kN/m XD 54.25 kN/m

- b. Tear Strength, ASTM D 5147
 - 1) 2 in/min. @ 73.4 +/- 3.6 deg. F MD 500 lbf XD 500 lbf
 - 2) 50 mm/min. @ 23 +/- 2 deg. C MD 2224 N XD 2224 N
 - c. Elongation at Maximum Tensile, ASTM D 5147
 - 1) 2 in/min. @ 73.4 +/- 3.6F MD 8% XD 8%
 - 2) 50 mm/min. @ 23 +/- 2 deg. C MD 8% XD 8%
 - d. Low Temperature Flexibility, ASTM D 5147, Passes -30 deg. F (-34 deg. C)
- C. Interply Adhesive:
1. **Alternate:** Weatherking:Rubberized, polymer modified cold process asphalt roofing bitumen V.O.C. compliant ASTM D 3019. Performance Requirements:
 - a. Non-Volatile Content ASTM D 4479 70%
 - b. Density ASTM D1475 8.9 lbs./gal.
 - c. Viscosity Stormer ASTM D562 400-500 grams
 - d. Flash Point ASTM D 93 100 deg. F min. (37 deg. C)
 - e. Slope: up to 3:12
 2. **Base Bid: Northfield Elementary & Nordonia Middle School** - Generic Type III Asphalt: Hot Bitumen, ASTM D 312, Type III steep asphalt having the following characteristics:
 - a. Softening Point 185 deg. F - 205 deg. F
 - b. Flash Point 500 deg. F
 - c. Penetration @ 77 deg. F 15-35 units
 - d. Ductility @ 77 deg. F 2.5 cm
 3. **Base Bid: Rushwood Elementary** - Generic Type IV Asphalt: Hot Bitumen, ASTM D 312, Type IV special steep asphalt having the following characteristics:
 - a. Softening Point 210 deg. F - 225 deg. F
 - b. Flash Point 500 deg. F
 - c. Penetration @ 77 deg. F 15-25 units
 - d. Ductility @ 77 deg. F 1.5 cm
- D. Flashing Base (Ply) Sheet:
1. FlexBase 80: 80 mil SBS (Styrene-Butadiene-Styrene) rubber modified roofing base sheet reinforced with a dual fiberglass reinforced scrim, performance requirements according to ASTM D 5147.
 - a. Tensile Strength, ASTM D 5147
 - 1) 2 in/min. @ 73.4 +/- 3.6 deg. F MD 225 lbf/in XD 225 lbf/in
 - 2) 50 mm/min. @ 23 +/- 2 deg. C MD 39.0 kN/m XD 39 kN/m
 - b. Tear Strength, ASTM D 5147
 - 1) 2 in/min. @ 73.4 +/- 3.6 deg. F MD 300 lbf XD 300 lbf
 - 2) 50 mm/min. @ 23 +/- 2 deg. C MD 1335 N XD 1335 N
 - c. Elongation at Maximum Tensile, ASTM D 5147
 - 1) 2 in/min. @ 73.4 +/- 3.6 deg. F MD 7% XD 7%
 - 2) 50 mm/min. @ 23 +/- 2 deg. C MD 7% XD 7%
 - d. Low Temperature Flexibility, ASTM D 5147, Passes -30 deg. F (-34.4 deg. C)
- E. Flashing Ply Adhesive:
1. **Alternate:** Flashing Bond: Asphalt roofing mastic V.O.C. compliant, ASTM D 4586, Type II trowel grade flashing adhesive.
 - a. Non-Volatile Content ASTM D 4479 70 min.
 - b. Density ASTM D 1475 8.3 lbs./gal. (1kg/l)
 - c. Flash Point ASTM D 93 103 deg. F (39 deg. C)
 2. **Base Bid: Northfield Elementary & Nordonia Middle School**- Generic Type III Asphalt: Hot Bitumen, ASTM D 312, Type III steep asphalt having the following characteristics:
 - a. Softening Point 185 deg. F - 205 deg. F
 - b. Flash Point 500 deg. F

- c. Penetration @ 77 deg. F 15-35 units
- d. Ductility @ 77 deg. F 2.5 cm
- 3. **Base Bid: Rushwood Elementary** - Generic Type IV Asphalt: Hot Bitumen, ASTM D 312, Type IV special steep asphalt having the following characteristics:
 - a. Softening Point 210 deg. F - 225 deg. F
 - b. Flash Point 500 deg. F
 - c. Penetration @ 77 deg. F 15-25 units

F. Surfacing:

- 1. **Drain Sump Cap Sheet & Section I Area Between the Drain and HVAC Unit:**
Millennium FR Mineral: 160 mil SBS (Styrene-Butadiene- Styrene) Mineral Surfaced Coal Tar polymer modified membrane with fire retardant characteristics utilizing polyester and fiberglass reinforcement.
 - a. Tensile Strength, ASTM D 5147
 - 1) 2 in/min. @ 73.4 +/- 3.6 deg. F MD 310 lbf/in XD 310 lbf/in
 - 2) 50mm/min. @ 23 +/- 2 deg. C MD 54.25 kN/m XD 54.25 kN/m
 - b. Tear Strength, ASTM D 5147
 - 1) 2 in/min. @ 73.4 +/- 3.6 deg. F MD 500 lbf XD 500 lbf
 - 2) 50mm/min. @ 23 +/- +2 deg. C MD 2224 N XD 2224 N
 - c. Elongation at Maximum Tensile, ASTM D 5147
 - 1) 2 in/min. @ 73.4 +/- 3.6 deg. F MD 3.5% XD 3.5%
 - 2) 50mm/min. @ 23 +/- 2 deg. C MD 3.5% XD 3.5%
 - d. Low Temperature Flexibility, ASTM D 5147, Passes -76 deg. F (-60 deg. C)
- 2. Drain Sump Adhesive:
 - a. Black-Knight/Black-Stallion Cold: Coal Tar protective roof coating; heavy-bodied, fiber reinforced, cold process polymer modified, coal tar roof coating having the following characteristics:
 - 1) Weight/Gallon 9.0 lbs./gal. (1.07 g/cm³)
 - 2) Solids by weight 87%
 - 3) Viscosity; Brookfield Heliopath, 2.5 rpm 120,000 cPs
 - 4) Roofing Aggregate: ASTM D 1863
- 3. Flood Coat/Aggregate:
 - a. Black-Knight/Black-Stallion Cold: Coal Tar protective roof coating; heavy-bodied, fiber reinforced, cold process polymer modified, coal tar roof coating having the following characteristics:
 - 1) Weight/Gallon 9.0 lbs./gal. (1.07 g/cm³)
 - 2) Solids by weight 87%
 - 3) Viscosity; Brookfield Heliopath, 2.5 rpm 120,000 cPs
 - 4) Roofing Aggregate: ASTM D 1863
 - a) #8, Wash Grade, Silica Pea gravel.
- 4. Surface Coatings: Exposed Flashing Membrane
 - a. Surfacing:
 - 1) Silver-Shield: ASTM D 2824 aluminum coating fibered aluminum roof coating fibered aluminum roof coating having the following characteristics:
 - a) Flash Point 100 deg. F (38 deg. C) min.
 - b) Weight/Gallon 8.2 lbs./gal. (1.0 g/cm³)
 - c) Viscosity (75 deg. F) 100 - 125 K.U

END OF SECTION

SECTION 07600 - SHEET METAL FLASHING AND TRIM

PART 1 - GENERAL

1.1 SECTION INCLUDES:

- A. Provide all labor, equipment, and materials fabricate and install the following.
 - 1. Shop Fabricated metal edge, extenders and trim.
 - 2. Surface mounted wall counterflashings over bituminous base flashing.
 - 3. Metal flashings,
 - 4. Counterflashings over bituminous base flashing.
 - 5. Counterflashings at roof mounted equipment and vent stacks.
 - 6. Counterflashings for roof accessories.
 - 7. Counterflashings at walls and penetrations.
 - 8. Lead flashing for bituminous membranes.
 - 9. Other components.

1.2 RELATED SECTIONS

- A. All Provided Sections

1.3 QUALITY ASSURANCE

- A. Reference Standards
 - 1. Comply with details and recommendations of SMACNA Manual for workmanship, methods of joining, anchorage, provisions for expansion, etc.
 - 2. ANSI/SPRI ES-1 Testing & Certification.
- B. If required, fabricator/installer shall submit work experience and evidence of adequate financial Responsibility. The owner's representative reserves the right to inspect fabrication facilities in determining qualifications.
- C. Successful contractor must obtain all components of roof system from a single manufacturer including any roll good materials if required. Any secondary products that are required, which cannot be supplied by the specified manufacturer, must be recommended and approved in writing by primary manufacturer prior to bid submittal.
- D. Manufacturer shall have in place a documented, standardized method for maintaining quality control such as ISO-9001 approval.
- E. The roof material manufacturer shall conduct all required periodic inspections a minimum of three (3) days a week of work in progress as described herein and shall furnish written documentation of all such inspections.

1.4 DELIVERY, STORAGE, AND HANDLING

- A. Deliver materials in manufacturer's original, unopened containers or packages with labels intact and legible.

- B. Stack pre-formed and pre-finished material to prevent twisting, bending, or abrasion, and to provide ventilation. Slope metal sheets to ensure drainage.
- C. Prevent contact with materials which may cause discoloration or staining.

1.5 JOB CONDITIONS

- A. Determine that work of other trades will not hamper or conflict with necessary fabrication and storage requirements for pre-formed metal roofing system.
- B. Protection:
 - 1. Provide protection or avoid traffic on completed roof surfaces.
 - 2. Do not overload roof with stored materials.
 - 3. Support no roof-mounted equipment directly on the roofing system.
- C. Ascertain that work of other trades which penetrates the roof or is to be made watertight by the roof, is in place and approved prior to installation of roofing.

1.6 DESIGN AND PERFORMANCE CRITERIA

- A. SMACNA
 - 1. Install per the published SMACN requirements or greater.

1.7 WARRANTIES

- A. Material Manufacturer's Warranty
 - 1. Pre-finished metal material shall require a written 30-year non-prorated warranty covering fade, chalking and film integrity. The material shall not show a color change greater than 5 NBS color units per ASTM D-2244 or chalking excess of 8 units per ASTM D-659. If either occurs material shall be replaced per warranty, at no cost to the Owner.
- B. Contractor's Warranty
 - 1. The Contractor shall provide the Owner with a notarized written warranty assuring that all sheet metal work including caulking and fasteners to be watertight and secure for a period of two (2) years from the date of final acceptance of the building. Warranty shall include all materials and workmanship required to repair any leaks that develop, and make good any damage to other work or equipment caused by such leaks or the repairs thereof.
- C. Manufacturer's Warranty
 - 1. Warranty shall also include the modified bitumen roof system and metal edge system, and shall be a single-source warranty provided by ONE manufacturer. Warranty will include the roof systems, metal coping cap, flashings, and the transition between all systems.

2. At the request of the Owner, the Manufacturer will provide an annual inspection. The request for annual inspections shall be applicable for the life of the warranty.

PART 2- PRODUCTS

2.1 MATERIALS

- A. Metal systems (metal coping cap system, metal edge system, slip flashings, etc.), are to be comprised of 22-Gauge Steel, coated on both sides with an epoxy primer and on the weathering surface with a polyvinylidene fluoride (Kynar) coated finish. Equipment counterflashings and slip flashings shall be mill finish. Pitch pockets shall be either stainless steel or 20 oz. copper, and have all corners welded or soldered, and a continuous deck flange at corners.
- B. Shop Fabricated Metal: The Garland Company, Inc
- C. Flat Stock = 22 gauge
- D. Pitch pockets shall be 22-gauge stainless steel, 20 oz. copper, or approved equal. All corners soldered or welded, and a continuous deck flange at corners.
- E. Miscellaneous Metals and Flashings:
 1. Architectural Metal Walls Panels: Metal trim and flashing is specified in Division 7 Section "Architectural Metal Wall Panels".
 2. Surface Mounted Counter Flashings: matching color, 22-gauge
 3. Copper Slip Counterflashings: ASTM B370, temper H00 (cold-rolled), 20 oz. copper
 4. Equipment Slip Flashing: Mill finished Aluminum, 0.040 inch thick.
 5. Equipment Support Flashing: Mill finished Aluminum, 0.040 inch thick.
 6. Solder for Stainless Steel: ASTM B 32, Grade Sn60, used with an acid flux of type recommended by stainless-steel sheet manufacturer; use a noncorrosive rosin flux over tinned surfaces.
 7. Solder for Copper: ASTM B 32, Grade Sn50, 50 percent tin and 50 percent lead.
 8. Fasteners: Same metal as sheet metal flashing or other noncorrosive metal as recommended by sheet metal manufacturer. Match finish of exposed heads with material being fastened. Exposed fasteners shall have a neoprene or other suitable weatherproofing washer.
 9. Asphalt Mastic: SSPC-Paint 12, solvent-type asphalt mastic, nominally free of sulfur and containing no asbestos fibers, compounded for 15-mil dry film thickness per coat.

10. Mastic Sealant: Polyisobutylene; nonhardening, nonskinning, nondrying, nonmigrating sealant.
11. Sealing Tape: Pressure sensitive, 100 percent solids, polyisobutylene compound sealing tape with release-paper backing. Provide permanently elastic, nonsag, nontoxic, nonstaining tape.
12. Adhesives: Type recommended by flashing sheet metal manufacturer for waterproof and weather-resistant seaming and adhesive application of flashing sheet metal.
13. Metal Accessories: Provide sheet metal clips, straps, anchoring devices, and similar accessory units as required for installation of Work, matching or compatible with material being installed; noncorrosive; size and thickness required for performance.
14. Roofing Cement: ASTM D 4586, Type I, asbestos free, asphalt based.
15. Zinc-Coated Steel Sheet: ASTM A526, 0.20% copper, 26 gage (0.0179"); designation G90 hot-dip galvanized, mill phosphatized.
16. Stainless Steel Sheet: Type 302/304, ASTM A167, 26 gage, (0.0217"), annealed except dead soft where fully concealed by other work, 2D (dull) finish.
17. Copper Sheet: ASTM B370, 20 oz., temper H00 (cold-rolled).
18. Lead-Coated Copper Sheet: ASTM B101. Type I, Class A (12-15 1 lb. of lead coating per 100 sq. ft.), 17.1 oz. (0.022").
19. Zinc Alloy Sheet: Zinc with 0.6% copper and 0.14% titanium; 0.27" thick (21 gauge); standard (soft) temper, mil finish.

2.2 RELATED MATERIALS

- A. Metal Primer: Zinc chromate type.
- B. Plastic Cement: ASTM D 4586
- C. Sealant: As required by material manufacturer.
- D. Lead: Meets Federal Specification QQ-L-201, Grade B, four pounds per square foot.
- E. Solder: ANSI/ASTM B32; 95/05 type.
- F. Flux: FS O-F-506.
- G. Underlayment: Ply of specified base flashing modified membrane or approved equal.
- H. Fasteners:
 1. Nails and Fasteners: Non-ferrous metal or hot dipped galvanized fasteners complying with ASTM A153 and connectors complying with ASTM A653, Class G185; Type 304 or Type 316 stainless steel fasteners and connectors shall be

used with new generation of pressure-treated wood; except that hard copper nails shall be used with copper; aluminum or stainless steel nails shall be used with aluminum; and stainless steel nails shall be used with stainless steel. Fasteners shall be self-clinching type of penetrating type as recommended by the manufacturer of the wood blocking/nailer material. Nails and fasteners shall be flush-driven through flat metal discs of not less than one (1) inch diameter. Omit metal discs when one-piece composite nails or fasteners with heads not less than one (1) inch diameter are used.

2. Fastening shall conform to ANSI/SPRI ES-1 and/or Factory Mutual 1-90 requirements or as stated on section details, whichever is more stringent and per the manufacturer's requirements.

I. Metal Termination Bars:

1. Shall be heavy flat bar aluminum unless otherwise recommended by membrane manufacturers.
2. Material shall be .125" x 1" (minimum) aluminum conforming to ASTM B-221, mill finish. Bars shall have holes for fasteners at 6" o.c. maximum.

PART 2 - EXECUTION

3.1 PROTECTION

- A. Isolate contact areas of dissimilar metals with heavy asphalt or other approved coating, specifically made to stop electrolytic action.

3.2 GENERAL

- A. Install work watertight, without waves, warps, buckles, fastening stress, or distortion, allowing for expansion and contraction.
- B. Fastening of metal to walls and wood blocking shall comply with ANSI-SPRI ES-1, SMACNA Architectural Sheet Metal Manual, Factory Mutual 1-100 wind uplift specifications and/or manufacturer's recommendations whichever is of the highest standard.
- C. All accessories or other items essential to the completeness of sheet metal installation, whether specifically indicated or not, shall be provided and of the same material as item to which applied.

3.3 INSPECTION

- A. Verify roof openings, curbs, pipes, sleeves, ducts, or vents through roof are solidly set, cant strips and reglets are in place, and nailing strips located.
- B. Verify membrane termination and base flashings are in place, sealed, and secure.
- C. Beginning of installation means acceptance of existing conditions.

D. Field measure site conditions prior to fabricating work.

3.4 SHOP FABRICATED SHEET METAL

- A. Installing Contractor shall be responsible for determining if the sheet metal systems are in general conformance with roof manufacturer's recommendations.
- B. Metal work shall be shop fabricated to configurations and forms in accordance with recognized sheet metal practices.
- C. Hem exposed edges.
- D. Angle bottom edges of exposed vertical surfaces to form drip.
- E. All corners for sheet metal shall be lapped with adjoining pieces fastened and set in sealant.
- F. Install sheet metal to comply with ANSI/SPRI, SMACNA and NRCA standards, and per the manufacturer's instructions.

3.5 FLASHING MEMBRANE INSTALLATION

A. ROOF DRAIN

- 1. Prime lead at a rate of 100 square feet per gallon and allow to dry.
- 2. Set lead flashing (30" square minimum) in a 1/4" bed of mastic.
- 3. Install specified roof flashing system.
- 4. Install metal clamping ring and strainer. Stop all plies short of the clamping ring and seal edge with a three course application of the specified liquid applied flashing system and reinforcing mesh.

B. PLUMBING STACK

- 1. Prime flange and sleeve at a rate of 100 square feet per gallon and allow to dry.
- 2. Install properly sized sleeves in a 1/4" bed of roof cement.
- 3. Turn sleeve a minimum of 1" down inside of stack or lead caps on pipes 2" or less in diameter.
- 4. Caulk intersection of the membrane and flange with asphalt roof cement.

C. EQUIPMENT SUPPORTS/EXHAUST VENTS

- 1. Mill finished aluminum counterflashing and/or slip flashing extender shall be provided with watertight accessories such as miters, transitions, end caps, etc. and finished to match.
- 2. Accessories: Joint covers, corners, fasteners, strip flashing at joinings, fastening, and other accessories shall be included.

3. On small units, install an 0.040 mill finished aluminum extender will be installed under the existing counterflashing or curb lip to cover the newly installed roof flashing system by at least 4 inches. The new extender will be secured with fasteners and neoprene washers every 8 inches on center.

D. PITCH POCKET

1. Prime flange and sleeve at a rate of 100 square feet per gallon and allow to dry.
2. Install properly sized and prefabricated stainless steel or copper pitch pockets with welded watertight joints in a 1/4" bed of roof mastic.
3. Install specified two ply roof flashing system.
4. Caulk intersection of the flashing membrane and flange with asphalt roof cement.
5. In accordance with project the detail, fill pitch pocket with non-shrink grout and pourable sealer.

E. COPING CAP SYSTEM

1. Accessories: Joint covers, seam sealant, seam tape, caulking, fasteners, and other accessories shall be included.
2. Where metal extender is required, install continuous cleat on the outside face of the wall and fasten to the masonry wall at 6" o.c.
3. Metal coping cap pieces shall be formed with 1/4" joints between sections. The joint shall be backed by an internal drainage plate formed to the profile of fascia piece. The metal coping cap shall be embedded in two (2) rows of butyl sealant tape over the internal drainage plate. The internal drainage plate shall be installed over the anchor chair. Install Miters first.
5. Position base flashing of the Modified Roofing membrane over the wall edge covering nailers completely, fastening eight (8) inches on center. Install membrane and cap sheet with proper material and procedure according to manufacturer's recommendations.
6. Install 8" wide splice plate by centering over sixteen (16) inch wide anchor chair. Install two (2) layers of butyl sealant tape, one (1) to either side of the splice plate's center. Approximately two (2) inches from the coping cap joint. Install Coping Cap by hooking outside hem of coping on outside face of anchor chair. Press downward on inside edge of coping until "snap" occurs and hem is engaged on the entire chair.

F. CURB DETAIL/AIR HANDLING STATION

1. Mill finish aluminum slip flashing extender shall be provided with watertight accessories such as miters, transitions, end caps, etc. and finished to match.

2. Accessories: Joint covers, corners, fasteners, strip flashing at joinings, fastening, and other accessories shall be included.
3. Over the termination bar, an 0.040 mill finished aluminum extender will be installed under the existing counterflashing or curb lip to cover the newly installed roof flashing system by at least 4 inches. New counterflashing will be secured with fasteners and neoprene washers every 8 inches on center.

END OF SECTION

PART 5 - CONTRACTOR'S QUALIFICATION STATEMENT

The undersigned certified under oath that the information provided herein is true and sufficiently complete so as not to be misleading.

Submitted to: Nordonia Hills City School District. Attn: Mr. Rick Wolf

Submitted by: Firm Name: _____

Address: _____

Principal Office Location: _____

Qualification Statement Submitted for - Project Name

Type of Work:

Site Preparation _____ General Construction _____
Roofing _____ Plumbing _____
HVAC _____ Sprinkler _____
Electrical _____ Other _____

(File separate form for each classification of work)

Organization:

Please provide the following information concerning your organization:

Type of Entity:
Corporation _____
Partnership _____
Individual _____
Other _____

Name of Principal, Owners or Partners

<u>Name</u>	<u>Position</u>	<u>Years of Service with Organization</u>
_____	_____	_____
_____	_____	_____
_____	_____	_____

Number of years this organization has been in business? _____

Have members of this organization operated under former Yes _____ No _____

names/businesses? If "yes," list name, type of entity and names of principal, owners or partners.

Provide a brief description of the general type of construction the firm performs. Please indicate for this project the work you intend to subcontract or perform.

	<u>Perform</u>	<u>Subcontract</u>
Earth Work	_____	_____
Concrete Work	_____	_____
Masonry Work	_____	_____
Structural Work	_____	_____
Roofing Work	_____	_____
Sprinkler	_____	_____
Plumbing	_____	_____
HVAC	_____	_____
Electrical	_____	_____

Experience

Please list the type and number of educational projects your firm has constructed which were subject to the Owner Guidelines and other Ohio regulatory agency construction requirements:

<u>Type</u>	<u>Number</u>
New Construction - Primary	_____
New Construction - Secondary	_____
Renovations - Primary	_____
Renovations - Secondary	_____

Please list on a separate sheet marked "Appendix A" the major construction projects your organization has in progress providing the name of project, owner, architect, contract amount, bonding company, insurance carrier, percentage complete and scheduled completion date.

Please list on a separate sheet marked "Appendix B" the major projects your organization has completed in the past five years, giving the name of project, owner, architect, contract amount, bonding company, date of completion and percentage of the cost of the work performed with your own forces.

Insurance and Bonds

Please list names of current insurance carrier and number of projects insured by carrier:

Please list names of bonding company/agent utilized for projects constructed during the last five years:

Claims and Suites

Has your organization ever failed to complete and construction work it has been awarded?

Yes ___ No ___

Within the last five years, has any officer or principal of your organization ever been an officer or principal of another organization when it failed to complete a construction contract? (If the answer is yes, please describe in full.)

Yes ___ No ___

Has there been in the last ten years, or is there now pending or threatened, any litigation, arbitration, investigation, or governmental or regulatory proceeding involving claims in excess of \$100,000 or requesting a declaratory judgment or injunctive relief with respect to the construction or operation of any building which your firm, its principals, predecessors or affiliates constructed?

Yes ___ No ___

Are all city, county, state and Federal taxes of any type, including real estate, FICA and Workmen's Compensation paid to date?

Yes ___ No ___

Is there any potential claim, demand, litigation, arbitration, investigation, governmental proceeding or regulatory proceeding involving your firm, or its principals, predecessors or affiliates? If the answer to either of the preceding questions is "Yes," please describe in full in an attachment.

Yes ___ No ___

In addition to the litigation, arbitration, investigation or governmental or regulatory proceeding referred to in the preceding paragraphs, is there any litigation, arbitration, investigation or governmental or regulatory proceeding now pending or threatened to which your firm is or may be a party, or are you aware of any potential claim or demand, which might otherwise affect the capacity of your firm to perform with respect to your involvement with the Owner, whether or not it concerns other work which you have undertaken? If so, please describe in full.

Yes ___ No ___

Bankruptcy

Has your firm, its principals, predecessors, or affiliates been the subject of any proceeding under the federal bankruptcy laws or any other proceedings under state or federal law in which a court or government agency has assumed jurisdiction over any of the assets or business of your firm, its principals, predecessors or affiliates? If so, please identify the proceedings, the court or governmental body and the date such jurisdiction was assumed in an attachment.

Yes ___ No ___

Change Order History

Describe each instance within the last five (5) years where change orders applied for during construction amounted in the aggregate to more than five percent (5%) of the contract price for any building which your firm constructed, or in which actual construction costs exceeded the contract price by more than five percent (5%) in an attachment.

Financial Condition

Please attach your organizations' last two (2) years' financial statements including your latest balance sheet and income statement showing the following:

Current assets (e.g., cash, joint venture accounts, receivable, accrued income, deposits, materials inventory and prepaid expenses):

Net Fixed Assets:

Other Assets:

Current Liabilities (e.g., accounts payable, notes payable, accrued expenses, provision for income taxes, advances, accrued salaries and accrued payroll taxes): List all older than 60 days.

Other Liabilities (e.g., capital stock, authorized and outstanding shares per values, earned surplus and retained earnings):

Name and address of firm preparing attached financial statement and date thereof.

References

Please list below Trade References:

Please list below Bank References:

END OF SECTION

ROOFING MANUFACTURER CHECK LIST:

COMPANY NAME:

Quality Assurance:

Manufacturer Qualifications: Shall have manufactured and warranted SBS Modified Bitumen Systems for at least 10 years in the United States.

1. *Are you an actual manufacturer of any of any of the main components of your specified roofing system?

yes or no

If so, please list these components for your specified roofing system.

2. *Please state how long your company has been a manufacturer of roofing products:

_____ years.

3. *Please list the address of your manufacturing plant for the product specified herein:

4. Please list your I.S.O. certification number as required in the bid documents.

5. The manufacturer of the Primary Waterproofing Membrane shall be currently certified by the International Organization for Standardization as meeting the minimum quality assurance standards outlined in the I.S.O. 9001 and/or I.S.O. 9001 program, and shall be registered in the current listing of I.S.O. Certified Manufacturers. The Manufacturers I.S.O. certification number must be included in the bid documents along with the name of the licensed quality assessment auditing firm issuing the certification.

6. How long has your company been manufacturing the “**exact**” roofing membrane/system which is specified for this project?
 _____years.

7. What is the oldest application of this “**exact**” specified roofing system your company has in place in the United States?
 _____years.

8. The manufacturer of the “SBS and SIS” roofing system which is specified shall have at least 5 hot asphalt applied modified “SBS and SIS” applications within a 50 miles radius which have been installed for at least 5 years. These applications shall be documented and available for site visitation if deemed necessary. Invoices proving polymer purchases may be requested by the Owner / Architect for verification.

List at least 5 references with contacts and phone numbers of 5 roofing projects (Municipal Projects) with the “**exact**” roofing system specified by your company for this project that are at least 5 years old. These projects must be within a 50 miles (or list miles) radius and they must be available for site visitation.

8.1 _____

8.2 _____

8.3 _____

8.4 _____

8.5 _____

9. As a representative of your company, how long have you personally been in the roofing business?
 _____ years.

10. Did you work for another roofing company before your present one? Yes or no

If yes, what company?

-
11. The materials manufacturer issuing the final guarantee on this roofing project must have a full time representative with at least 5 years of field experience in all phases of built up roofing that lives within a seventy-five (75) mile radius of the proposed project. This employee will serve as a Manufacturer's Representative during the project.

If you do not have 5 years of field experience who will be your company's Manufacturer's Representative during this project? Please list name, address and phone number so that we may verify information with this person:

12. Submit all UL and Factory Mutual documentation for this project as stated below. Again, our office requires separate documentation for each different structural roofing deck encountered on this roofing project. Documentation will be required showing that the **“exact”** specified roofing system, exact configurations and thickness' of roofing insulation and any base sheet passes the listed Fire and Wind Uplift tests.

13. Requirements of Regulatory Agencies:

- 13.1 Underwriter's Laboratories, Inc.; Built-Up Roof Covering-Class A fire hazard classification. The **“exact”** specified roofing system must meet all requirements of UL 790/E-108 Fire Test. Bidder shall furnish documentation from UL/Underwriters Laboratories that the proposed roofing system has passed UL 790/E-108 Fire Test for the exact structural roof decking, insulation and **“SBS and SIS”** modified bitumen built up roofing system as specified. Similar applications which are not exact will not be considered due to safety concerns. In cases where several different structural roofing decks are encountered on a roofing project, documentation will be required showing that the **“exact”** specified roofing system and roofing insulation passes UL 790/E-108 Fire Test over each different type of structural roofing deck.

- 13.2 Factory Mutual: The **“exact”** specified roofing system must meet all requirements of FM 4470 Class 1, A, I-90 (Class 1 **“Internal Fire Rating”**, A **“External Fire Rating”**, I-90 **“Wind Uplift Rating”**). Bidder shall furnish documentation from Factory Mutual that the proposed roofing system has passed FM 4470 for the exact structural roof decking,

insulation and SBS/SIS modified bitumen built up roofing system as specified. Similar applications which are not exact will not be considered due to safety concerns. In cases where several different structural roofing decks are encountered on a roofing project, documentation will be required showing that the exact specified roofing system and roofing insulation passes FM 4470 over each different type of structural roofing deck.. (Note: Structural roof decks which are not approved by Factory Mutual are excluded from these requirements.)

14. Submit the following as stated in the specifications:
 - 14.1 A sample of all modified membranes installed in your “**exact**” specified roofing system, including any base sheets, cap sheets and flashing sheets.
 - 14.2 A verified data sheet showing physical and performance attributes of your companies modified bitumen cap sheet and/or flashing sheet. This data sheet shall list Tensile Strength (MD and CMD), Tear Strength (MD and CMD), Elongation at Maximum Tensile (MD and CMD), and Low Temperature Flexibility.
- NOTE: This testing shall conform to ASTM D-5147 and all testing for tensile, tear and elongation shall be performed at 77 Degrees F. Tests at 0 Degrees F will not be considered.
15. What percentage of rubber is in your “**exact**” specified modified cap sheet? _____%
(What blend of modifier is in your cap sheet? SBS SBS/SIS SBS/SIS/SEBS)
16. If you do not have a modified cap sheet in this specification, what is the percentage of rubber is in your base sheet? _____%
(What blend of modifier is in your base sheet? SBS SBS/SIS SBS/SIS/SEBS)
17. Submit a Ultra-violet microscopy analysis photograph showing a sample of the minimum 16% “SBS and SIS” modified asphalt sample used in the “**exact**” specified membrane for this particular roofing project. This submitted compound must currently be used in the manufacturing of the “**exact**” modified membrane by the submitting manufacturer and it must look similar to the blend of the specified manufacturer which is included in these bid documents.
18. Each roofing manufacturer shall be required to submit, at the time of bidding, a minimum 12” x 12” or maximum 18” x 18” actual mockup representation of the “**exact**” specified roofing system to be installed including, insulation, fiberboard, fasteners, moppings, base sheet, cap sheet, flood coat and gravel surfacing and flashings. Each layer shall be stepped back exposing the layer below it and each layer shall be clearly marked as to its name and specifications. These samples shall be used to illustrate each roofing system to the Owner for the purpose of awarding the contract. Any roofing system not submitted according to this description will not be approved as an acceptable bid.
19. Manufacturer shall warrant that the work of this Section will be water-tight and free from defects in materials and workmanship for a period of thirty (30) years from the date of acceptance of the work.
NOTE: This guarantee must be signed by an officer of the Parent Company. Officers of subsidiaries or divisions of the Parent Company are not acceptable personnel to sign the roofing warranty.

NOTE: A sample copy of the final warranty must be submitted to The Owner at least one hundred twenty (120) hours prior to the bid opening along with a letter from the officer of the Parent Company stating that they are authorized to sign the submitted 30 year guarantee upon the completion of this project as outlined in this section.

20. Consideration will be given only to those materials that have approval prior to the scheduled bid opening date.
21. The Architect/Owner reserves the right to be the final authority on the acceptance or rejection of any proposed alternate materials.
22. *Failure to comply with all particulars as outlined herein, shall be considered as reason for rejection of bid.
23. The Signature below is certification that the Signatory is the authorized representative of The Company, and that the Signatory further acknowledges that to the best of his/her knowledge, the information provided has been verified by The Company and is true and correct.

Signature

Company

Date

NOTARY SEAL

BID GUARANTY AND CONTRACT BOND
O.R.C. Sec. 153.571

KNOW ALL MEN BY THESE PRESENTS, that we, the undersigned

_____ as PRINCIPAL
(full name or legal title of Contractor and address)

and

_____ as SURETY are
(full name or legal title of Surety)

hereby held and firmly bound unto _____ as
(full name or legal title of owner)

OBLIGEE in the penal sum of the dollar amount of the bid submitted by the
PRINCIPAL to the OBLIGEE on _____ to undertake the project
(Date)

known as _____
(Insert full name of project)

The penal sum referred to herein shall be the dollar amount of the PRINCIPAL'S bid to the OBLIGEE, incorporating any additive or deductive proposals made by the PRINCIPAL on the date referred to above to the OBLIGEE, which are accepted by the OBLIGEE. In no case shall the penal sum exceed the amount of (\$ _____) Dollars.

(If the foregoing blank is not filled in, the penal sum will be the full amount of the PRINCIPAL'S bid, including alternates. Alternatively, if the blank is filled in, the amount stated must not be less than the full amount of the bid including alternates, in dollars and cents. A percentage is not acceptable) For the payment of the penal sum well and truly to be made, we hereby jointly and severally bind ourselves, our heirs, executors, administrators, successors, and assigns.

THE CONDITION OF THE ABOVE OBLIGATION IS SUCH, that whereas the above named PRINCIPAL has submitted a bid for the above referenced project.

NOW, THEREFORE, if the OBLIGEE accepts the bid of the PRINCIPAL and the PRINCIPAL fails to enter into a proper contract in accordance with the bid, plans, details, specifications, and bills of material; and in the event the PRINCIPAL pays to the OBLIGEE not to exceed ten per cent of the penalty hereof between the amount specified in the bid and such larger amount for which the OBLIGEE may in good faith contract with the next lowest bidder to perform the work covered by the bid; or in the event the OBLIGEE does not award the contract to the next lowest bidder and resubmits the project for bidding, the PRINCIPAL pays to the OBLIGEE the difference not to exceed ten percent of the penalty hereof between

the amount specified in the bid, or the costs, in connection with the resubmission, of printing new contract documents, required advertising, and printing and mailing notices to prospective bidders, whichever is less, then this obligation shall be null and void, otherwise to remain in full force and effect; if the OBLIGEE accepts the bid of the PRINCIPAL and the PRINCIPAL within ten days after the awarding of the contract enters into a proper contract in accordance with the bid, plans, details, specifications, and bills of material, which said contract is made a part of this bond the same as though set forth herein;

NOW ALSO, if the said PRINCIPAL shall well and faithfully do and perform each and every condition of such contract according to the terms of said contract; and shall pay all lawful claims of subcontractors, materialmen, and laborers, for labor performed and materials furnished in the carrying forward, performing, or completing of said contract; we agreeing and assenting that this undertaking shall be for the benefit of any materialman or laborer having a just claim, as well as for the OBLIGEE herein; then this obligation shall be void; otherwise the same shall remain in full force and effect; it being expressly understood and agreed that the liability of the SURETY for any and all claims hereunder shall in no event exceed the penal amount of this obligation as herein stated.

The said SURETY hereby stipulates and agrees that no modifications, omissions, or additions, in or to the terms of the said contract or in or to the plans or specifications therefor shall in any way wise affect the obligations of said SURETY on its bond, and it does hereby waive notice of any such modifications, omissions or additions to the terms of the contract or to the work of the specifications.

Signed this _____ day of _____, 20_____.

PRINCIPAL

BY: _____

TITLE: _____

SURETY

BY: _____

SURETY ADDRESS

Street

City, State Zip

SURETY AGENT:

Street

City, State Zip

THIS **AFFIDAVIT** IS TO FILLED OUT AND EXECUTED BY THE BIDDER:
IF THE BID IS MADE OUT BY A CORPORATION, THEN BY ITS
PROPERLY AUTHORIZED AGENT

STATE OF OHIO, COUNTY OF _____,

----- (NAME OF BIDDER)

RESIDING AT _____ BEING DULY SWORN DOES

DEPOSE AND SAY
THAT _____

(NAMES AND ADDRESS OF ALL OTHER PERSONS)

IS THE ONLY PARTY INTERESTED IN THE PROFITS OF THE HEREIN CONTAINED BID;
THAT THE SAID BID IS MADE WITHOUT ANY CONNECTION OR INTEREST IN THE
PROFITS THEREOF WITH ANY OTHER PERSON MAKING THE BID OR PROPOSAL FOR
SAID WORK; THAT SAID BID IS IN ALL RESPECTS FAIR, AND WITHOUT COLLUSION OF
FRAUD; AND ALSO THAT NO MEMBER OF, HEAD OF ANY DEPARTMENT OR BUREAU, OR
EMPLOYEE THEREIN, OR ANY OFFICER OF THE BOARD OF EDUCATION OF THE
_____ SCHOOL DISTRICT, IS DIRECTLY OR
INDIRECTLY INTERESTED THEREIN.

(SIGNATURE OF BIDDER)

SUBSCRIBED AND SWORN TO THIS _____

DAY OF _____ 20____ BEFORE _____
(NOTARY PUBLIC)

My commission expires _____.

Seal:

THIS **STATEMENT** IS TO BE SIGNED AND INCLUDED WITH THE BID

DETAILED SPECIFICATIONS, LEGAL ADVERTISEMENT, AFFIDAVIT OF PECUNIARY INTEREST, BOND (OR CERTIFIED CHECK), AND PROVISIONS OF SEC. 3313.46 OF THE REVISED CODE OF OHIO, ARE HEREBY MADE A PART OF THIS PROPOSAL AND THE BIDDER HEREBY ACKNOWLEDGES THAT HE HAS READ AND UNDERSTANDS THEM.

(BIDDER)

COMPANY

ADDRESS

WAIVER OF DELINQUENT PERSONAL PROPERTY TAX

This is to certify that _____
(Name of Company)

_____ is not _____ is charged with any delinquent personal property taxes on the general tax list of personal property of any county in which the taxing district has territory. If charged with delinquent personal property taxes on any such list, submit with this statement the amount of such due and unpaid delinquent taxes and any due and unpaid penalties and interest thereon.

Date

Official Signature

Signed in my presence this _____ day of _____, 20_____.

Notary

My commision expires _____.

Seal:

Rushwood Elementary School Roof Replacement Scope of Work – Sections E, D, & E1 through

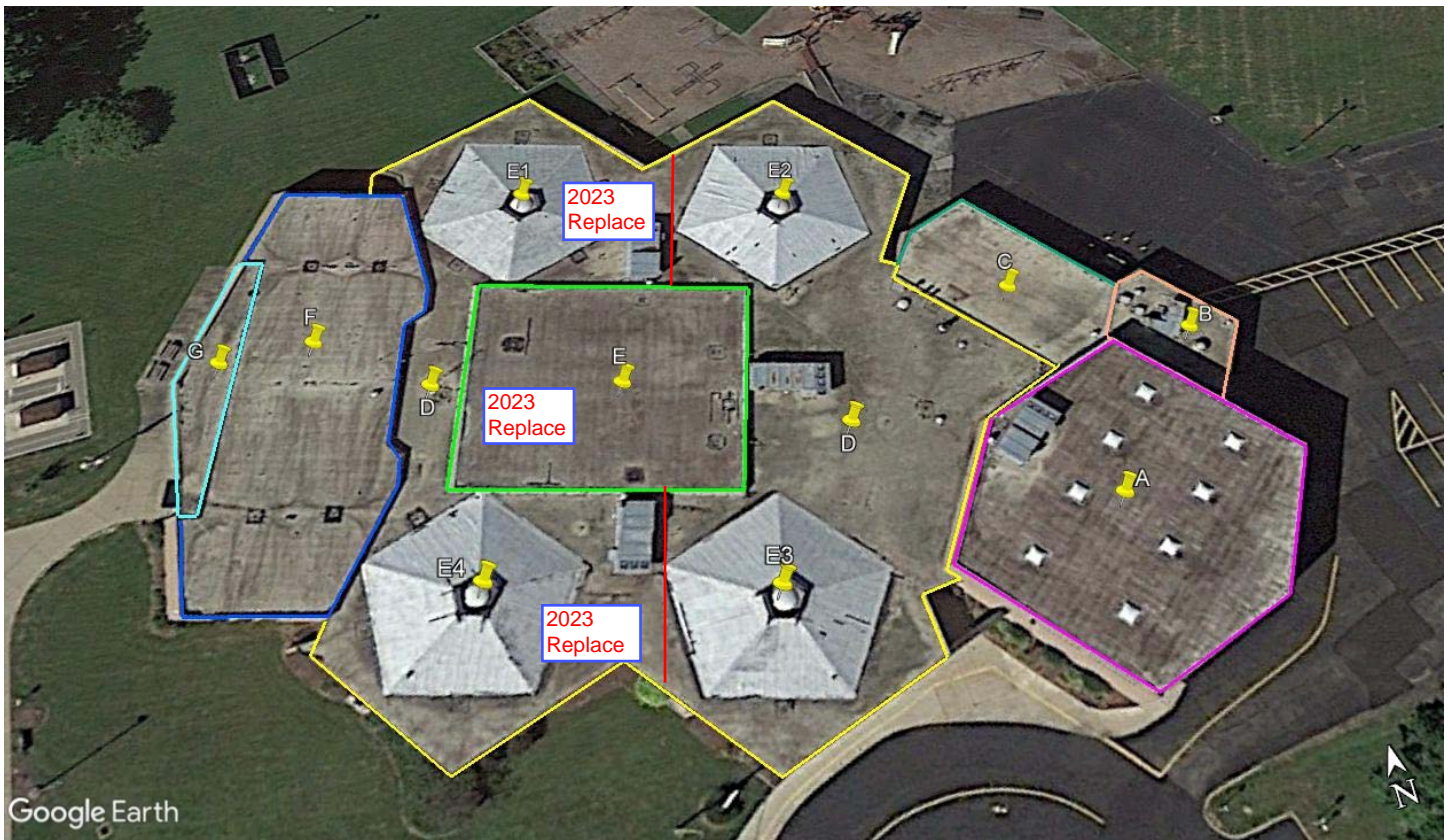

Sections E, E1, & E4: Roof Replacement Scope of Work

- 1.) Comply with all OSHA and Norderia Hill's City Schools housekeeping rules.
- 2.) Remove all roofing materials down to the roof deck.
 - **Section E Core Cut** = metal deck + 3 layers of perlite + BUR and Gravel



- **Section D Core Cut** = Metal deck + 2.5" ISO + Perlite + BUR and Gravel.



- **Section E1 to E4 Core Cut (3/12 pitch)** = tectum deck + roof plies and gravel + phenolic foam + HD board + modified roof plies.



3.) **Section E:** mechanically attach a minimum base layer of 1.5" ISO per the provided wind uplift calculations + 1/8" tapered system using full moppings of type IV hot asphalt. An average R-value of 25 must be achieved.

Alternate: set the tapered insulation in approved cold adhesive.

4.) **Section E1 & E4:** Mechanically attach a type II base using Olylok 1.8" base sheet fasteners or 1.7" FM approved twin leg base sheet fasteners. Space the fasteners 9" on center.

5.) Install an insulation stops at the low side of the tectum deck and high side just below the pitch pockets equaling the thickness of the insulation and coverboard. Use auger fasteners. Ensure the plies are properly secured.

6.) **Section E1 & E4:** Use full moppings of type IV hot asphalt to install 2 layers of 2.2" ISO insulation.

Alternate: set the insulation in approved cold adhesive.

7.) Install saddles/crickets where needed throughout. Ensure positive drainage exists throughout.

8.) Install a 1/2" HD wood fiber board using full moppings of type IV hot asphalt.

Alternate: set the fiber board in approved cold adhesive.

9.) Install the base and cap sheet using full moppings of type IV hot asphalt.

Alternate: set the base and cap sheet in cold adhesive.

- 10.) **Section D** - envelope the newly installed roof section from the existing roof. Install a modified ply using cold extending from the roof surface to the decking.
- 11.) Install a new 2-ply flashing system. All vertical seams are to be 3-coursed with Silver Flash.
- 12.) Install new pitch pockets with a cap throughout. 2-Part liquid flashing can be used on the difficult/low flashing height details.
- 13.) Flood coat the entire roof surface with cold process coal tar at the rate of 5 gallons per 100 sq. ft. Immediately imbed #8 wash grade, silica pea gravel at the rate of 450 lbs. per square feet.
- 14.) Install new skylights equaling the existing size with curbs extending a minimum of 8 inches above the roof surface.
- 15.) Install 2' x 2' gravel guards around all drains. Install a cold applied, coal tar mineral cap sheet in all sumped drains using cold applied coal tar adhesive.
 - Note: if new drain inserts are installed no gravel guard is needed. Apply the flood coat and gravel to the drain collar of the insert.
- 16.) **Section D to F:** Install a new wall to roof expansion joint (JM or approved equal).
- 17.) Install a new 22-gauge, shop fabricated, metal coping, edge metal, and metal trim throughout.
- 18.) **Walls of Section E** - Seal the vertical joints of the metal panels with seam tape and the specified coating – CPR Trowel Grade.

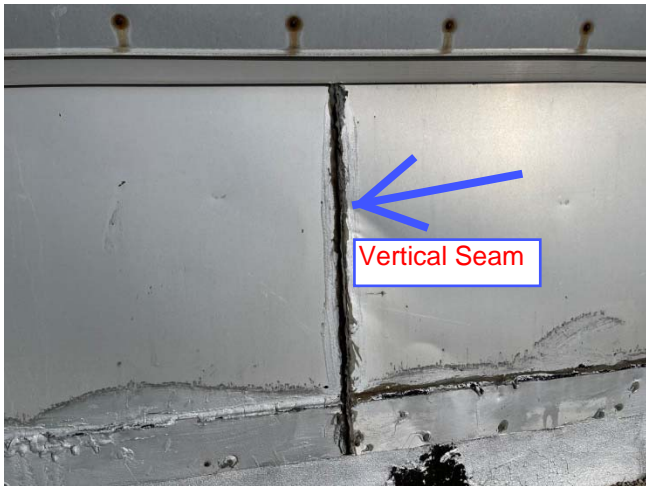

- Contractor shall Provide a 2-year Leak Free Warranty.
- The Garland Company shall provide a 30-year leak free warranty covering both labor and material.

***NOTE: The school district will provide (TBD) 2.2" insulation. The insulation material cost is not to be included in the bid.**



The Garland Company, Inc.

GENERAL NOTES:

1.) IT IS THE ROOFING CONTRACTOR'S RESPONSIBILITY TO FAMILIARIZE THEMSELVES WITH ALL DETAILS INVOLVED IN THE ROOFING CONTRACT.

2.) ALL DRAWINGS ARE GRAPHIC REPRESENTATION OF APPROXIMATE LOCATIONS OF EXISTING AND NEW MATERIALS. IT IS THE CONTRACTOR'S RESPONSIBILITY TO VERIFY ALL EXISTING CONDITIONS PRIOR TO COMMENCEMENT OF WORK.

3.) THE ROOFING CONTRACTOR TO PROTECT ALL ADJACENT SURFACES NOT SCHEDULED FOR WORK AND TO REPAIR ANY DAMAGED AREAS AS A RESULT OF CONTRACTOR WORK AT NO ADDITIONAL COST TO THE OWNER.

4.) THE ROOFING CONTRACTOR SHALL BE RESPONSIBLE TO MAINTAIN WATER TIGHTNESS AND PROVIDE PROTECTION AT ANY/ALL OPENINGS IN THE ROOF LEFT AT THE END OF EACH CONSTRUCTION DAY.

5.) CONTRACTOR SHALL FIELD VERIFY ALL DIMENSIONS, CONDITIONS AND QUANTITIES.

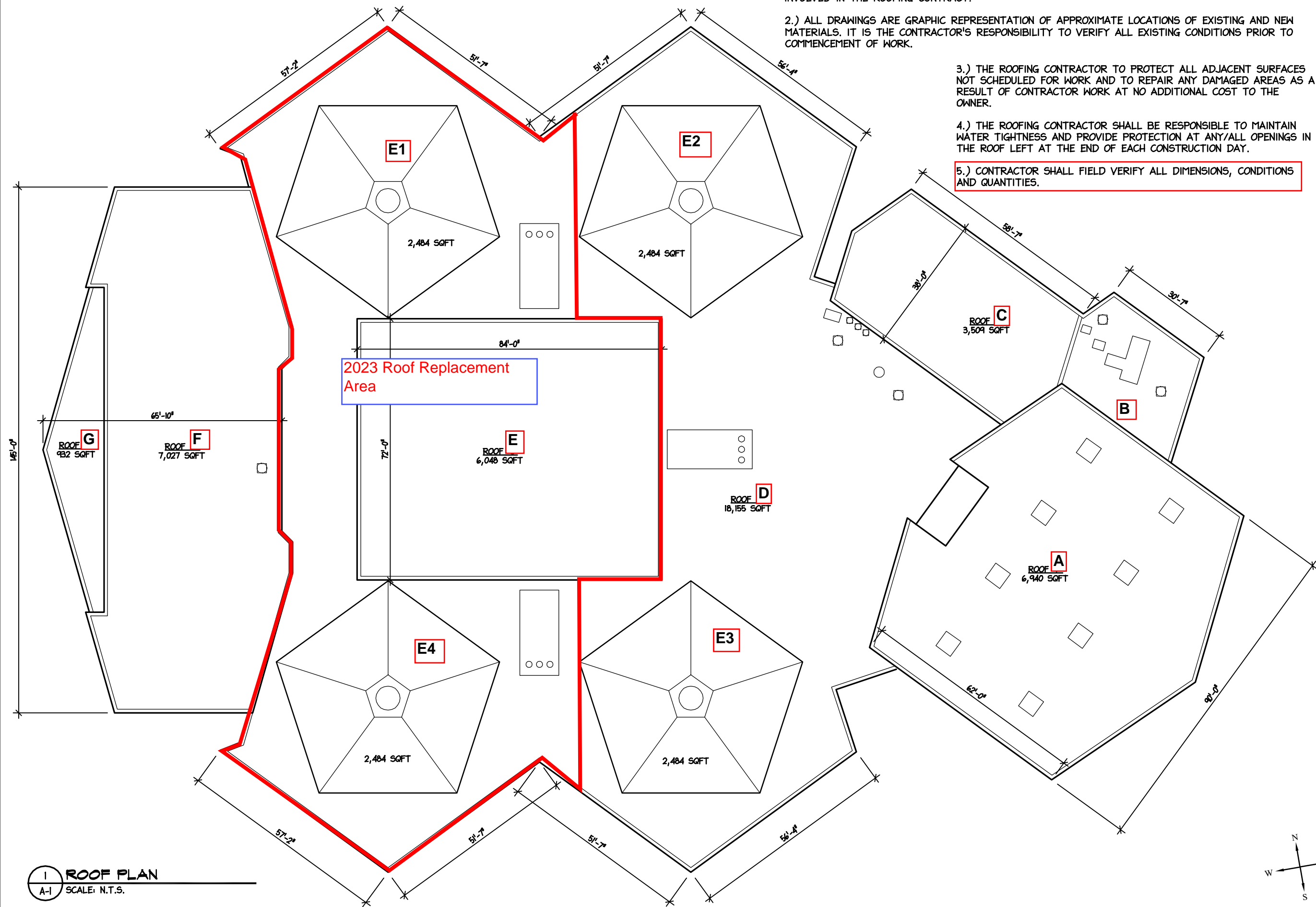

2023 Roof Replacement Area

1 ROOF PLAN
A-1 SCALE: N.T.S.

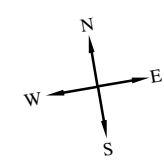

Rushwood

Elementary School

8200 Rushwood Lane
Northfield, OH

SCALE: AS NOTED
DATE: 02/08/2016
PROJ. #:
DRAWN BY:
REV. Δ:
REV. Δ:
REV. Δ:
2015

ROOF PLAN

A-1

Northfield Elementary School Roof Replacement Scope of Work – Sections A, C, & I

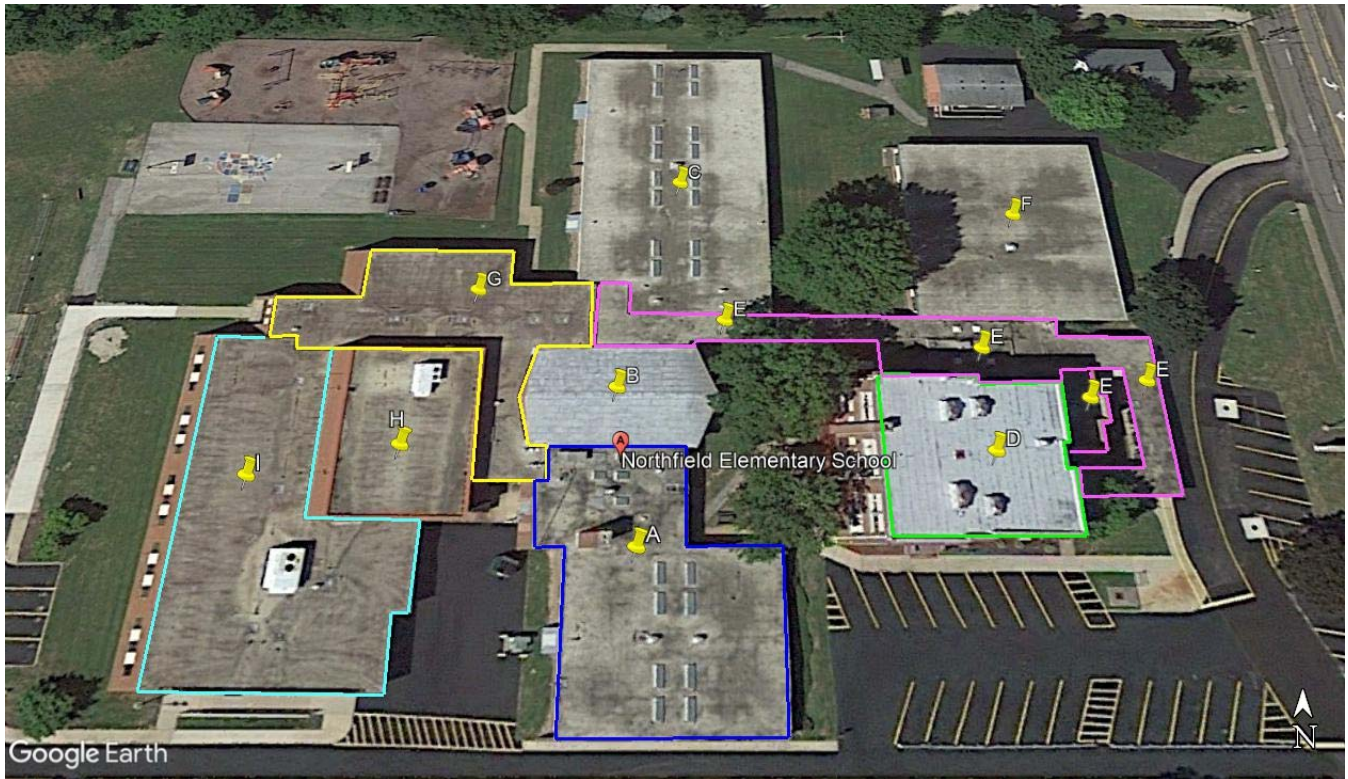

Sections A & C: Roof Replacement Scope of Work

- 1.) Comply with all OSHA and Nordonia Hill's City Schools housekeeping rules.
- 2.) Remove all roofing materials down to the roof deck.
 - Core cut = flat tectum deck (did not cut all the way) + 1st roof + ISO + CB + BUR Flood and Gravel



- 3.) Remove the existing skylights and install new $\frac{3}{4}$ " ply or 18-gauge steel decking. Secure to the surrounding metal beams and infill with ISO insulation.
- 4.) Mechanically attach a type II base using Olylok 1.8" base sheet fasteners or 1.7" FM approved twin leg base sheet fasteners. Space the fasteners 9" on center.
- 5.) Install an $\frac{1}{8}$ " tapered system using full moppings of hot asphalt. An average R-value of 25 must be achieved. Install saddles/crickets where needed. Positive drainage must be achieved.

Alternate: set the insulation in approved cold adhesive.

6.) Install a ½" HD wood fiber board using full moppings of hot asphalt.

Alternate: set the fiber board in approved cold adhesive.

7.) Install the base and cap sheet using full moppings of hot asphalt.

Alternate: set the base and cap sheet in cold adhesive.

8.) Install a new 2-ply flashing system. All vertical seams are to be 3-coursed with Silver Flash.

9.) Install new pitch pockets with a cap throughout. 2-Part liquid flashing can be used on the difficult/low flashing height details.

10.) Flood coat the entire roof surface with cold process coal tar at the rate of 5 gallons per 100 sq. ft. Immediately imbed #8 wash grade, silica pea gravel at the rate of 450 lbs. per square feet.

11.) Install 2' x 2' gravel guards around all drains. Install a **cold applied, coal tar mineral cap sheet in all sumped drains using cold applied coal tar adhesive.**

- Note: if new drain inserts are installed no gravel guard is needed. Apply the flood coat and gravel to the drain collar of the insert.

12.) Install a new 22-gauge, shop fabricated, metal coping, edge metal, and metal trim throughout.

Section I: Roof Replacement Scope of Work

1.) Comply with all OSHA and Nordonia Hill's City Schools housekeeping rules.

2.) Remove all roofing materials down to the roof deck.

- Core cut = tapered metal deck + 3.5" ISO + 1/2" coverboard + 2 ply BUR and gravel.



3.) Mechanically attach 2 layers of 2.2"ISO* + ½" coverboard set in hot asphalt. Install new saddles throughout. Sump the roof drains. Install saddles/crickets where needed. Positive drainage must be achieved.

Alternate: set the cover board in approved cold adhesive.

4.) Install the base and cap sheet using full moppings of hot asphalt.

Alternate: set the base and cap sheet in cold adhesive.

5.) Install a new 2-ply flashing system. All vertical seams are to be 3-coursed with Silver Flash.

Alternate: set the base and cap sheet in cold adhesive.

6.) Install new pitch pockets with a cap throughout. 2-Part liquid flashing can be used on the difficult/low flashing height details.

7.) Install new expansion joints between Sections G & I.

8.) Flood coat the entire roof surface with cold process coal tar at the rate of 5 gallons per 100 sq. ft. Immediately imbed #8 wash grade, silica pea gravel at the rate of 450 lbs. per square feet.

9.) Install new over flow drain inserts throughout.



10.) Install 2' x 2' gravel guards around all drains. Install a cold applied, **coal tar mineral cap sheet in all sumped drains using cold applied coal tar adhesive.**

- Note: if new drain inserts are installed no gravel guard is needed. Apply the flood coat and gravel to the drain collar of the insert.

11.) Install a cold applied, **coal tar mineral cap sheet set in coal tar adhesive** in the area between the HVAC unit and drain

12.) Install a new 22-gauge, shop fabricated, metal coping, edge metal, and metal trim throughout.

- **Contractor shall Provide a 2-year Leak Free Warranty.**
- **The Garland Company shall provide a 30-year leak free warranty covering both labor and material.**

***NOTE: The school district will provide (TBD) 2.2" insulation. The insulation material cost is not to be included in the bid.**

GENERAL NOTES:

- 1.) IT IS THE ROOFING CONTRACTOR'S RESPONSIBILITY TO FAMILIARIZE THEMSELVES WITH ALL DETAILS INVOLVED IN THE ROOFING CONTRACT.
- 2.) ALL DRAWINGS ARE GRAPHIC REPRESENTATION OF APPROXIMATE LOCATIONS OF EXISTING AND NEW MATERIALS. IT IS THE CONTRACTOR'S RESPONSIBILITY TO VERIFY ALL EXISTING CONDITIONS PRIOR TO COMMENCEMENT OF WORK.
- 3.) THE ROOFING CONTRACTOR TO PROTECT ALL ADJACENT SURFACES NOT SCHEDULED FOR WORK AND TO REPAIR ANY DAMAGED AREAS AS A RESULT OF CONTRACTOR WORK AT NO ADDITIONAL COST TO THE OWNER.
- 4.) THE ROOFING CONTRACTOR SHALL BE RESPONSIBLE TO MAINTAIN WATER TIGHTNESS AND PROVIDE PROTECTION AT ANY/ALL OPENINGS IN THE ROOF LEFT AT THE END OF EACH CONSTRUCTION DAY.
- 5.) CONTRACTOR SHALL FIELD VERIFY ALL DIMENSIONS, CONDITIONS AND QUANTITIES.



since 1895

The Garland Company, Inc.

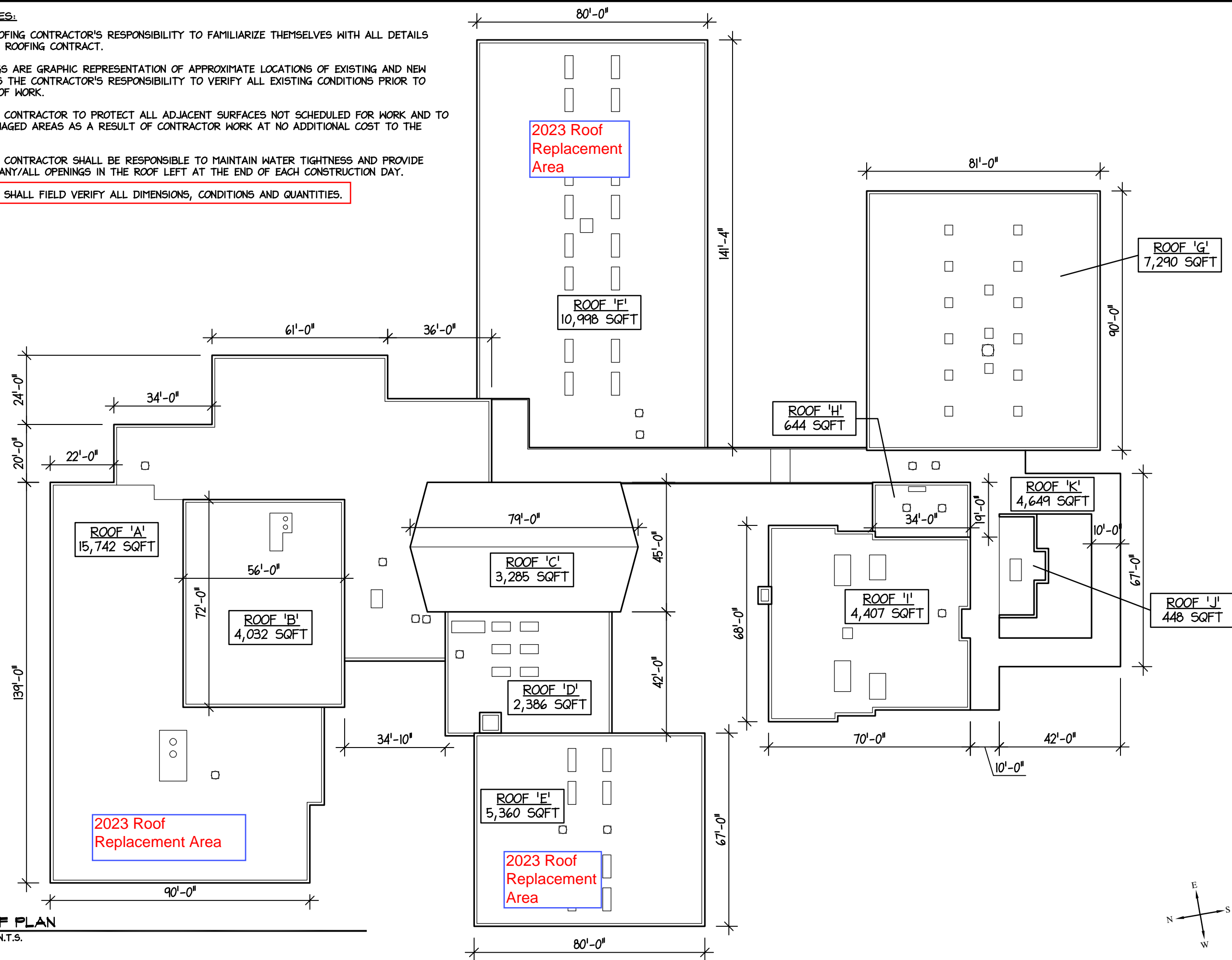

Northfield
Elementary School
9370 Olde 8 Road
Northfield, OH

SCALE: AS NOTED
DATE: 02/12/2016
PROJ. #:
DRAWN BY:
REV. Δ:
REV. Δ:
REV. Δ:
2015

ROOF PLAN

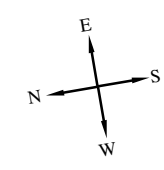

1 ROOF PLAN
A-1 SCALE: N.T.S.

A-1

PROJECT INFORMATION

Project: Nordonia School Areas A and C
 Location:
 Date: 2/20/23 Page #: 1 of 1
 Version #: 1
 Tapered Slope: 1/8"
 Cricket Slope: 1/4"
 Base Layer: Noted R-Value: 25.70
 Minimum Thickness: 2.00"
 Maximum Thickness: 7.13"

SHOP DRAWING APPROVAL

I understand that the information provided to the SRS Technical Design Department has been reviewed and approved and the layout of materials are in compliance to project documents and existing field conditions.

Signature

Company

Date

Panel Information

Panel Code:	Description:	Size:	Typ. PSI	Slope:	Used As:
AA	0.50" - 1.00"	4'x4'	20	1/8" FT	Tapered Panel
A	1.00" - 1.50"	4'x4'	20	1/8" FT	Tapered Panel
B	1.50" - 2.00"	4'x4'	20	1/8" FT	Tapered Panel
C	2.00" - 2.50"	4'x4'	20	1/8" FT	Tapered Panel
X	0.50" - 1.50"	4'x4'	20	1/4" FT	Cricket Panel
Y	1.50" - 2.50"	4'x4'	20	1/4" FT	Cricket Panel
2.00"	2.00" Flat	4'x4'	20	Flat	Fill Panel

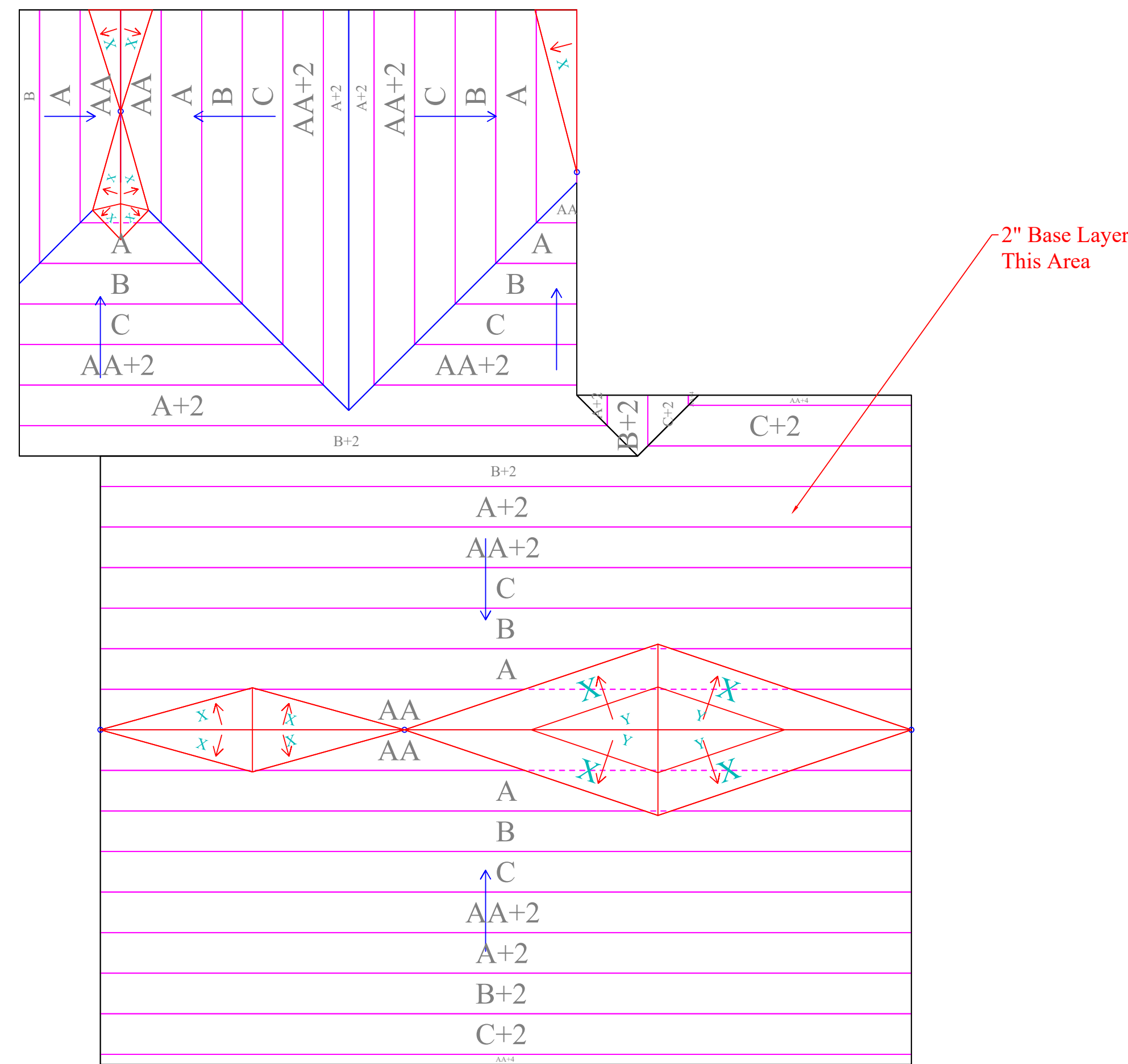

Area A Tapered Roof Plan

Not to Scale

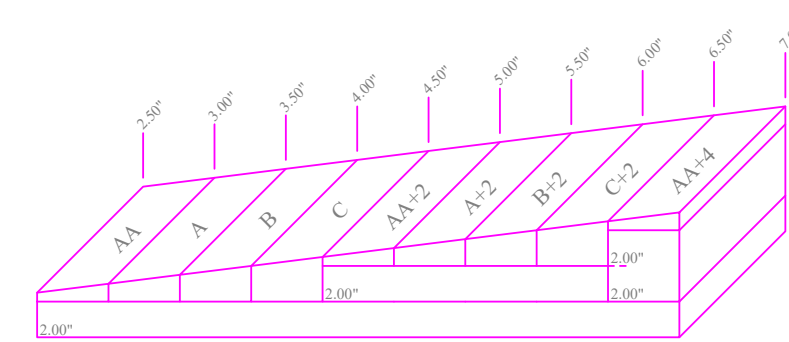

1/8" PER FOOT Tapered Detail

NOT TO SCALE

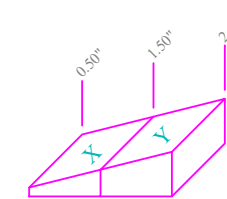

1/4" PER FOOT Cricket Detail

NOT TO SCALE

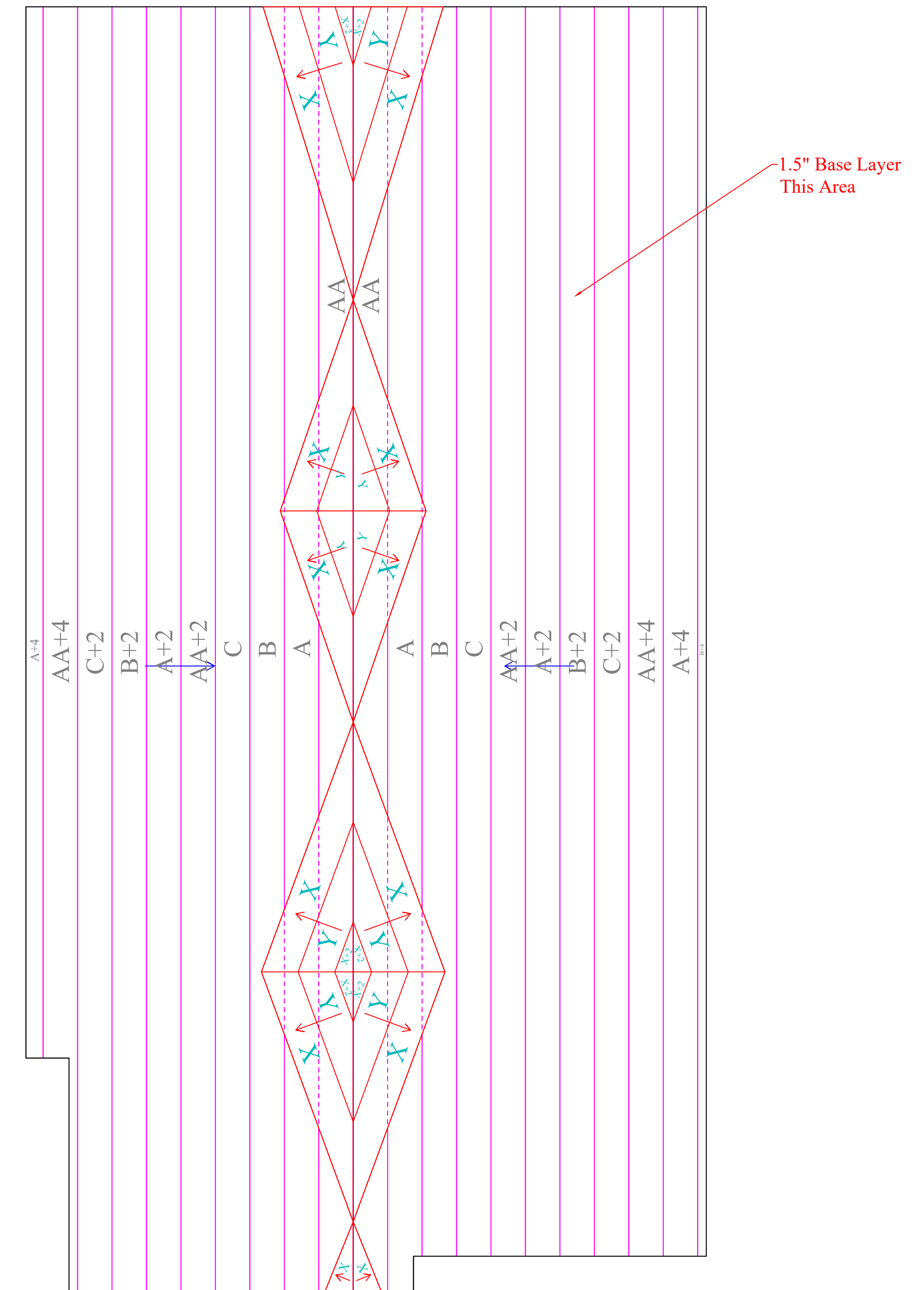

Area C Tapered Roof Plan

Not to Scale

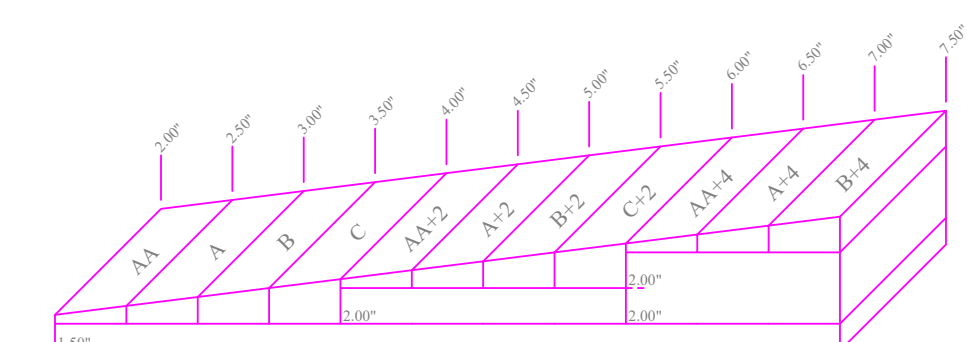

1/8" PER FOOT Tapered Detail

NOT TO SCALE

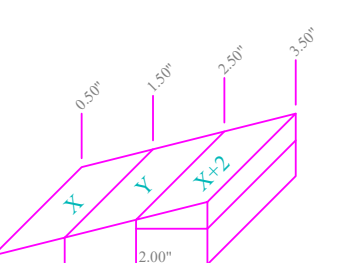

1/4" PER FOOT Cricket Detail

NOT TO SCALE

Northfield Middle School Roof Replacement Scope of Work – Sections J & K



Sections J & K: Roof Replacement Scope of Work

- 1.) Comply with all OSHA and Nordonia Hill's City Schools housekeeping rules.
- 2.) Remove all roofing materials down to the roof deck.
 - **Core cut** = metal deck + perlite board + ISO insulation + HD board + BUR & gravel.



- 3.) Mechanically attach a minimum base layer of 1.5" ISO per the provided wind uplift calculations + 1/8" tapered system using full moppings of hot asphalt. An average R-value of 25 must be achieved.

Alternate: set the insulation in approved cold adhesive.

- 4.) Install a 1/2" HD wood fiber board using full moppings of hot asphalt.

Alternate: set the fiber board in approved cold adhesive.

5.) Install the base and cap sheet using full moppings of hot asphalt.

Alternate: set the base and cap sheet in cold adhesive.

6.) Install a new 2-ply flashing system. All vertical seams are to be 3-coursed with Silver Flash.

7.) Install new pitch pockets with a cap throughout. 2-Part liquid flashing can be used on the difficult/low flashing height details.

8.) Flood coat the entire roof surface with cold process coal tar at the rate of 5 gallons per 100 sq. ft. Immediately imbed #8 wash grade, silica pea gravel at the rate of 450 lbs. per square feet.

9.) Install 2' x 2' gravel guards around all drains. Install a **cold applied, coal tar mineral cap sheet in all sumped drains using cold applied coal tar adhesive.**

- Note: if new drain inserts are installed no gravel guard is needed. Apply the flood coat and gravel to the drain collar of the insert.

10.) Install a new 22-gauge, shop fabricated, metal coping, edge metal, and metal trim throughout.

- **Contractor shall Provide a 2-year Leak Free Warranty.**
- **The Garland Company shall provide a 30-year leak free warranty covering both labor and material.**

***NOTE: The school district will provide (TBD) 2.2" insulation. The insulation material cost is not to be included in the bid.**

GENERAL NOTES:

- 1.) IT IS THE ROOFING CONTRACTOR'S RESPONSIBILITY TO FAMILIARIZE THEMSELVES WITH ALL DETAILS INVOLVED IN THE ROOFING CONTRACT.
- 2.) ALL DRAWINGS ARE GRAPHIC REPRESENTATION OF APPROXIMATE LOCATIONS OF EXISTING AND NEW MATERIALS. IT IS THE CONTRACTOR'S RESPONSIBILITY TO VERIFY ALL EXISTING CONDITIONS PRIOR TO COMMENCEMENT OF WORK.
- 3.) THE ROOFING CONTRACTOR TO PROTECT ALL ADJACENT SURFACES NOT SCHEDULED FOR WORK AND TO REPAIR ANY DAMAGED AREAS AS A RESULT OF CONTRACTOR WORK AT NO ADDITIONAL COST TO THE OWNER.
- 4.) THE ROOFING CONTRACTOR SHALL BE RESPONSIBLE TO MAINTAIN WATER TIGHTNESS AND PROVIDE PROTECTION AT ANY/ALL OPENINGS IN THE ROOF LEFT AT THE END OF EACH CONSTRUCTION DAY.
- 5.) ALL WOOD BLOCKING USED SHALL BE PRESSURE TREATED.

6.) CONTRACTOR SHALL FIELD VERIFY ALL DIMENSIONS, CONDITIONS AND QUANTITIES.

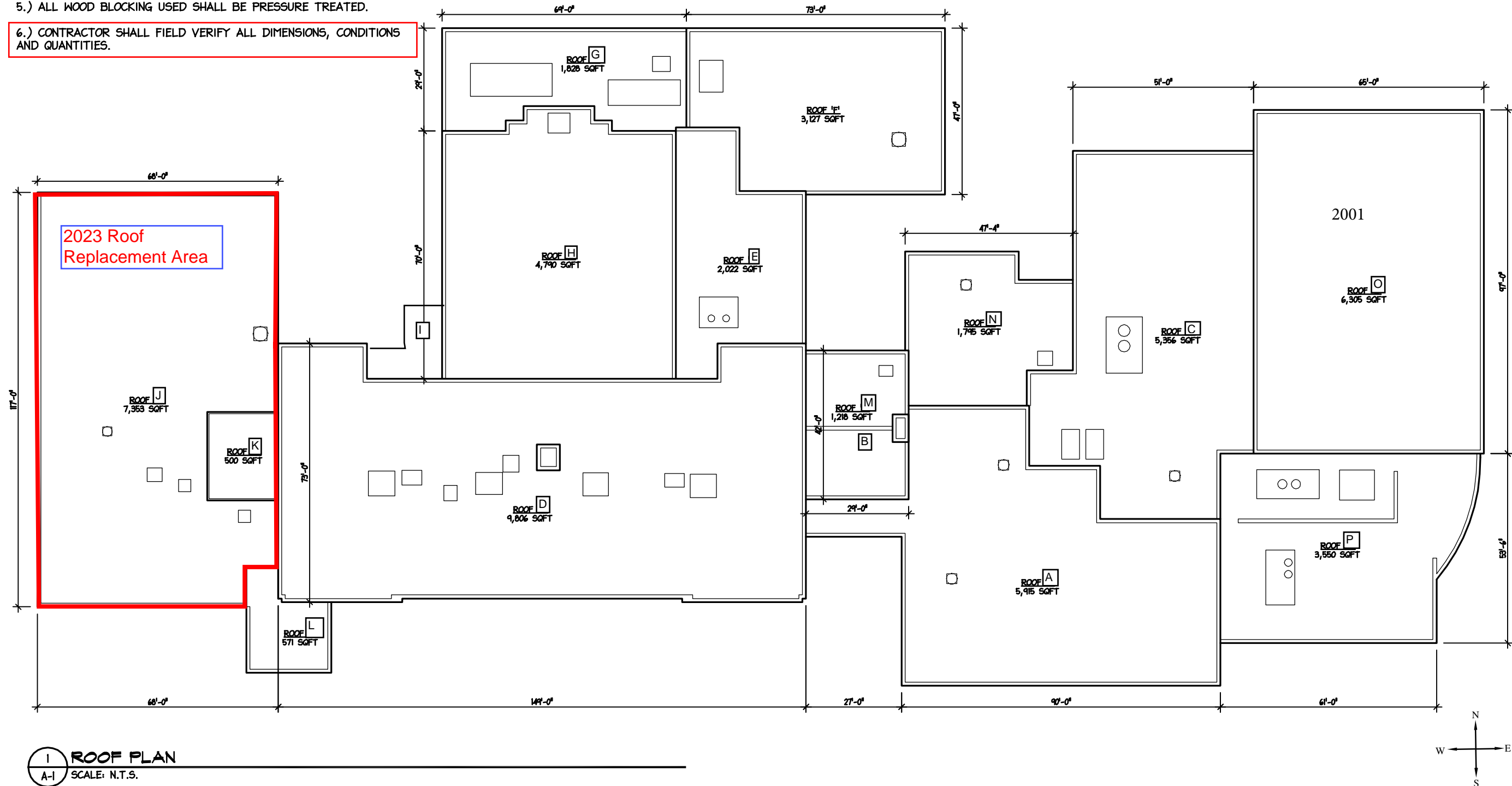

since 1895

The Garland Company, Inc.

Nordonia

Middle School

73 Leonard Ave
Northfield, OH

SCALE: AS NOTED

DATE: 02/08/2016

PROJ. #:

DRAWN BY:

REV. Δ:

REV. Δ:

REV. Δ:

2016

ROOF PLAN

1 ROOF PLAN
A-1 SCALE: N.T.S.

A-1

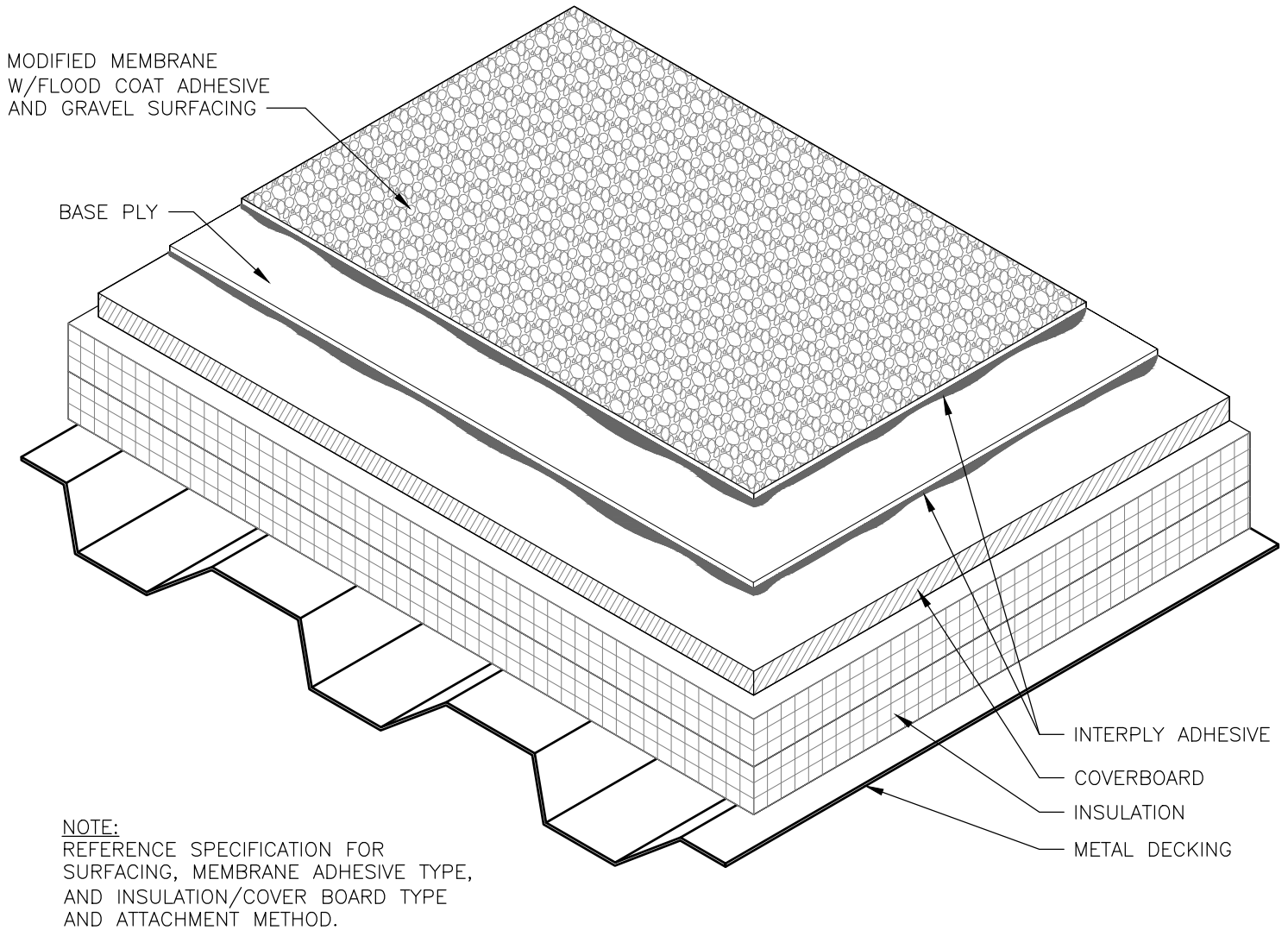

DRAWINGS ON 8½"x11 TITLE BLOCKS ARE NOT TO SCALE.

TYPICAL ROOF SYSTEM GRAVEL SURFACE



THE GARLAND COMPANY, INC.
GARLAND CANADA, INC.
THE GARLAND COMPANY UK, LTD

PROJECT:	
CUSTOMER:	
ARCHITECT:	
REPRESENTATIVE:	
DATE:	SHT: OF

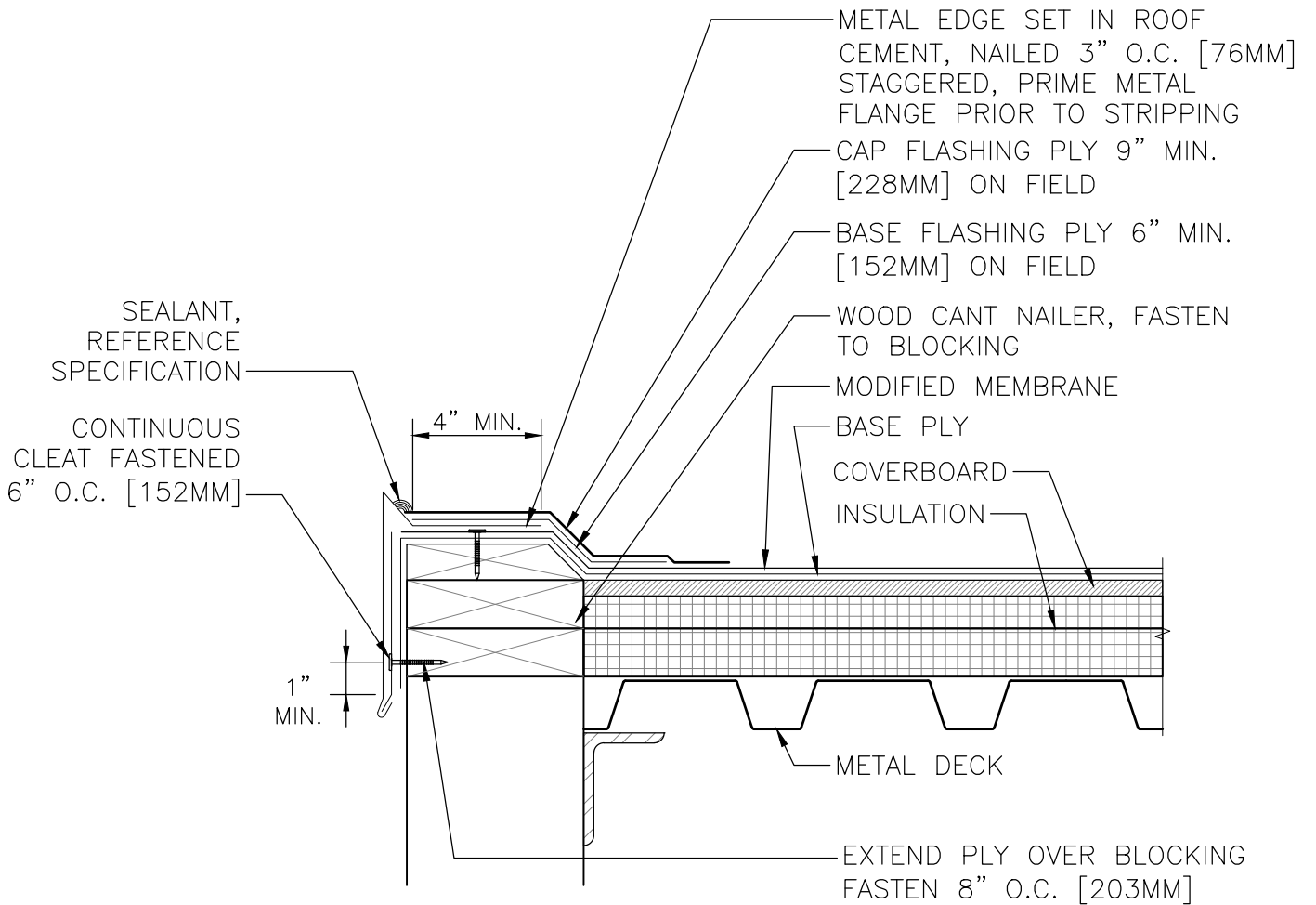

NOTE:
 REFERENCE SPECIFICATION FOR SURFACING, MEMBRANE ADHESIVE TYPE, AND INSULATION/COVER BOARD TYPE AND ATTACHMENT METHOD.

DRAWINGS ON 8½"x11 TITLE BLOCKS ARE NOT TO SCALE.

METAL EDGE - RAISED



THE GARLAND COMPANY, INC.
 GARLAND CANADA, INC.
 THE GARLAND COMPANY UK, LTD

PROJECT:	
CUSTOMER:	
ARCHITECT:	
REPRESENTATIVE:	
DATE:	SHT: OF

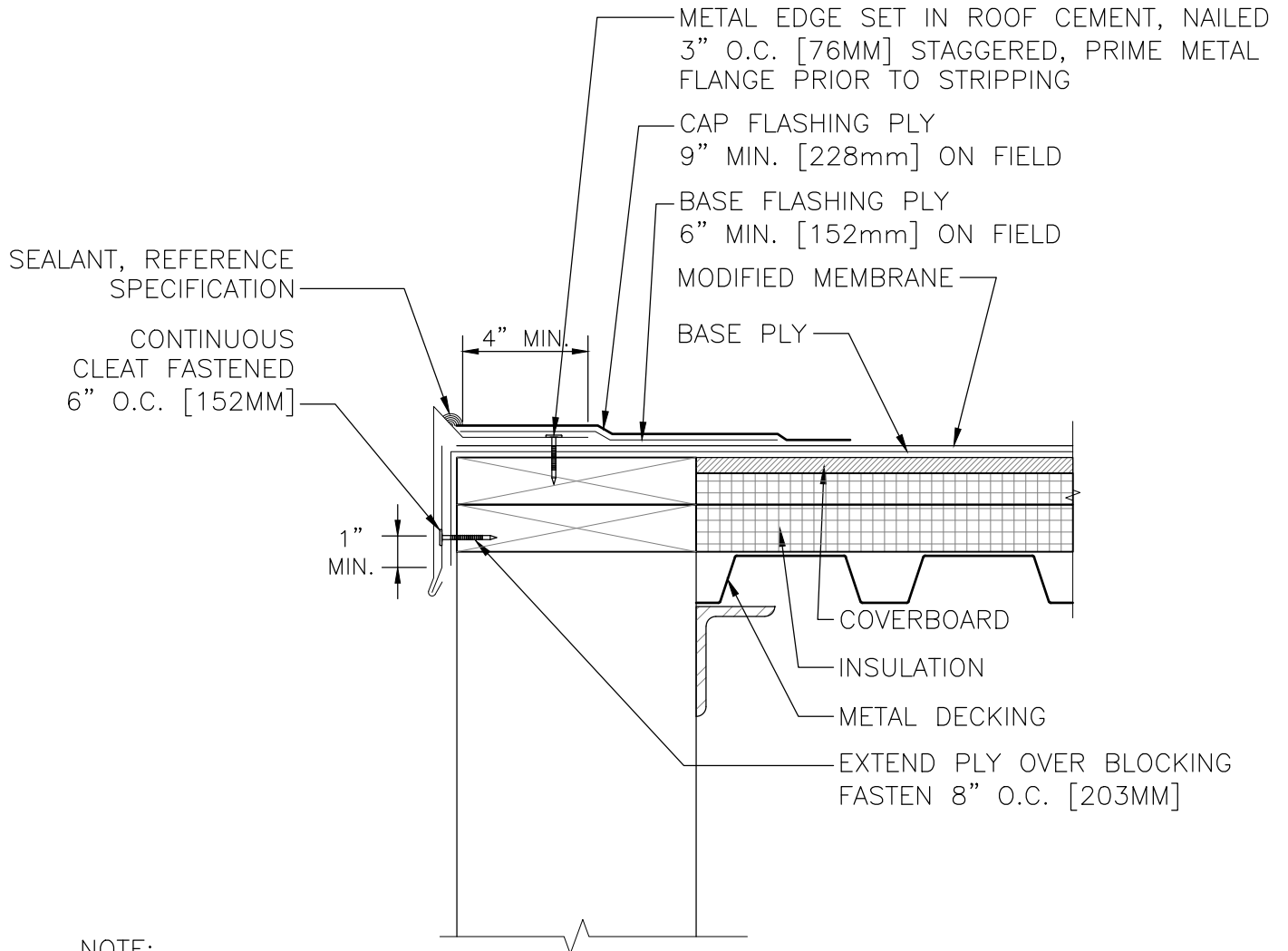

NOTE:
 REFERENCE SPECIFICATION FOR SURFACING, MEMBRANE ADHESIVE TYPE, AND INSULATION/COVER BOARD TYPE AND ATTACHMENT METHOD.

DRAWINGS ON 8½"x11 TITLE BLOCKS ARE NOT TO SCALE.

METAL EDGE - GRAVEL STOP



THE GARLAND COMPANY, INC.
 GARLAND CANADA, INC.
 THE GARLAND COMPANY UK, LTD

PROJECT:	
CUSTOMER:	
ARCHITECT:	
REPRESENTATIVE:	
DATE:	SHT: OF

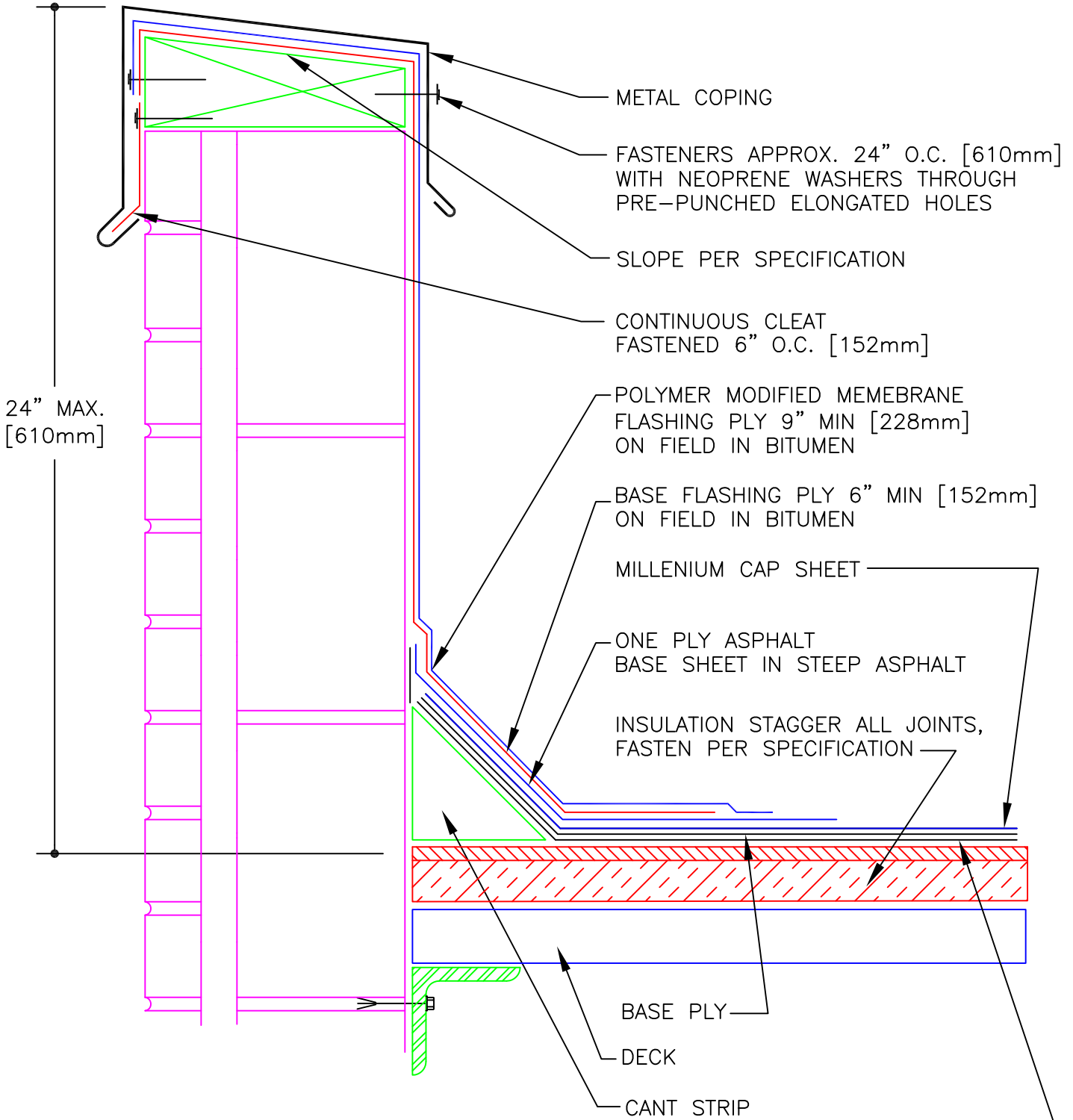

ALL PLIES SET IN BITUMEN
SEE SPECIFICATIONS FOR SURFACING

OPTIONAL: ONE PLY ASPHALT BASE SHEET IN STEEP ASPHALT



THE GARLAND COMPANY, INC.
GARLAND CANADA, INC.
THE GARLAND COMPANY UK, LTD

DETAIL:

C O P I N G C A P

HOT APPLIED

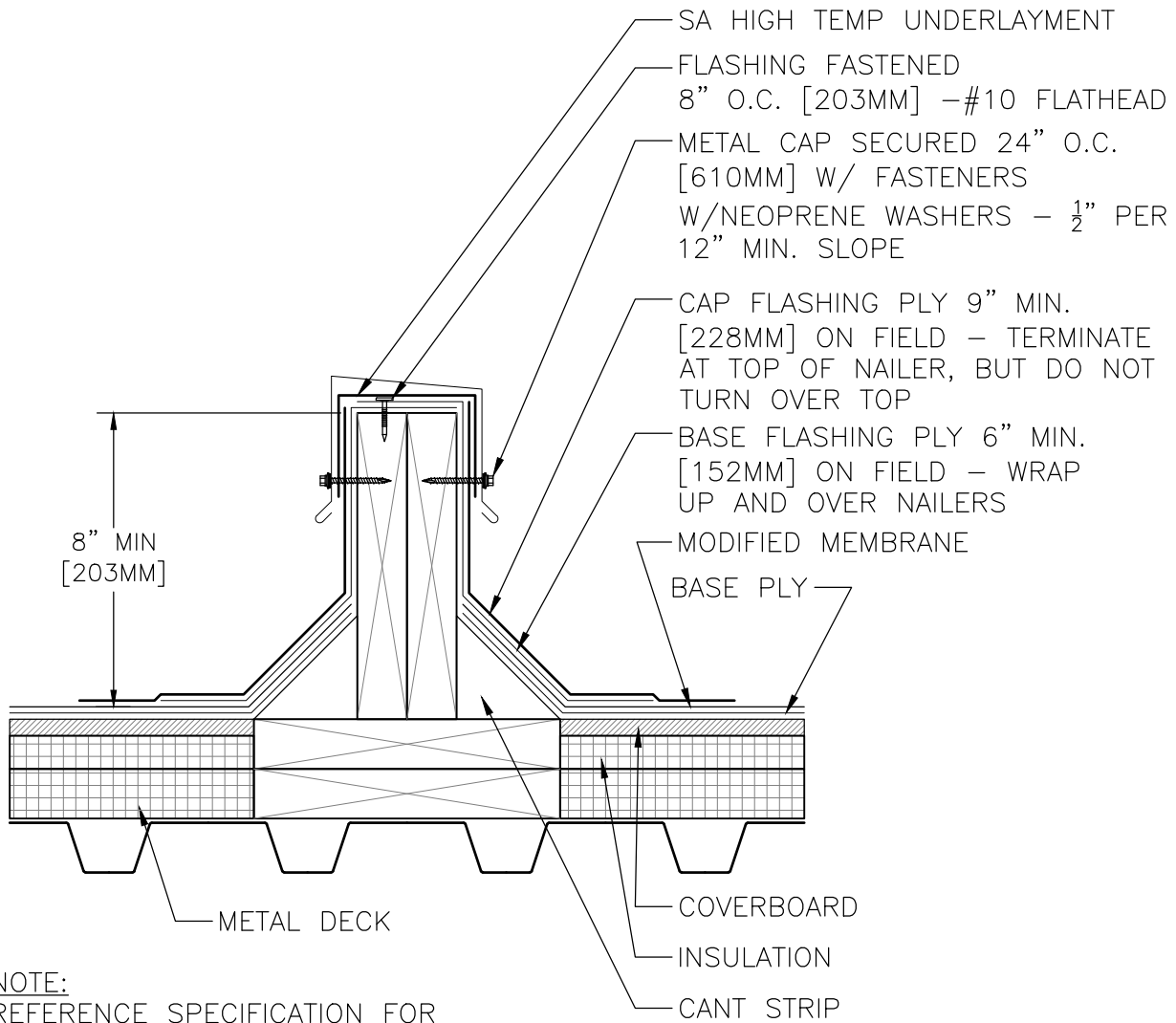

NOTE:
REFERENCE SPECIFICATION FOR
SURFACING, MEMBRANE ADHESIVE TYPE,
AND INSULATION/COVER BOARD TYPE
AND ATTACHMENT METHOD.

DRAWINGS ON 8 1/2"x11 TITLE BLOCKS ARE NOT TO SCALE.

AREA DIVIDER



THE GARLAND COMPANY, INC.
GARLAND CANADA, INC.
THE GARLAND COMPANY UK, LTD

PROJECT:	
CUSTOMER:	
ARCHITECT:	
REPRESENTATIVE:	
DATE:	SHT: OF

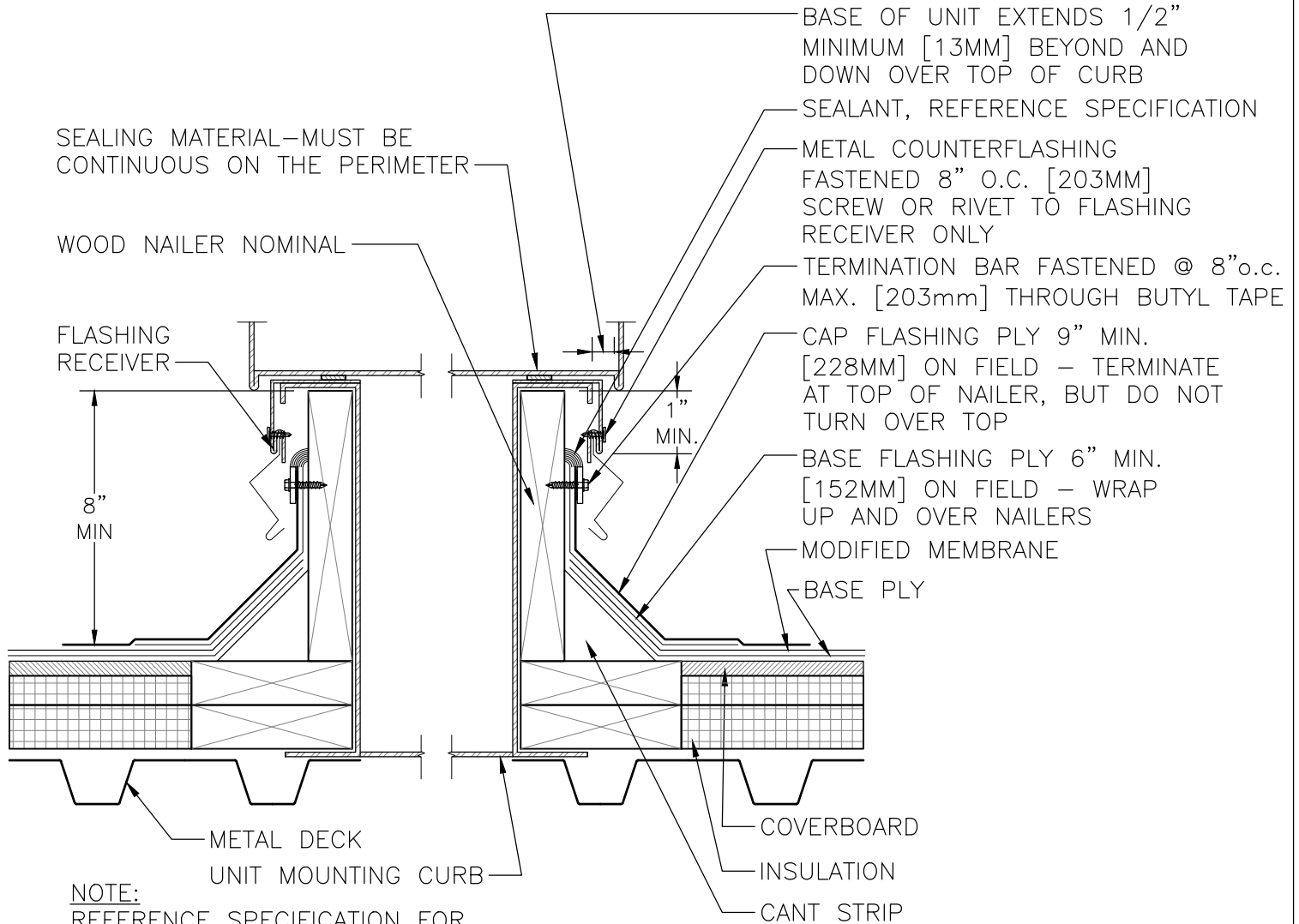

NOTE:
 REFERENCE SPECIFICATION FOR SURFACING, MEMBRANE ADHESIVE TYPE, AND INSULATION/COVER BOARD TYPE AND ATTACHMENT METHOD.

DRAWINGS ON 8 1/2"x11 TITLE BLOCKS ARE NOT TO SCALE.

CURB DETAIL / AIR HANDLING STATION



THE GARLAND COMPANY, INC.
 GARLAND CANADA, INC.
 THE GARLAND COMPANY UK, LTD

PROJECT:	
CUSTOMER:	
ARCHITECT:	
REPRESENTATIVE:	
DATE:	SHT: OF

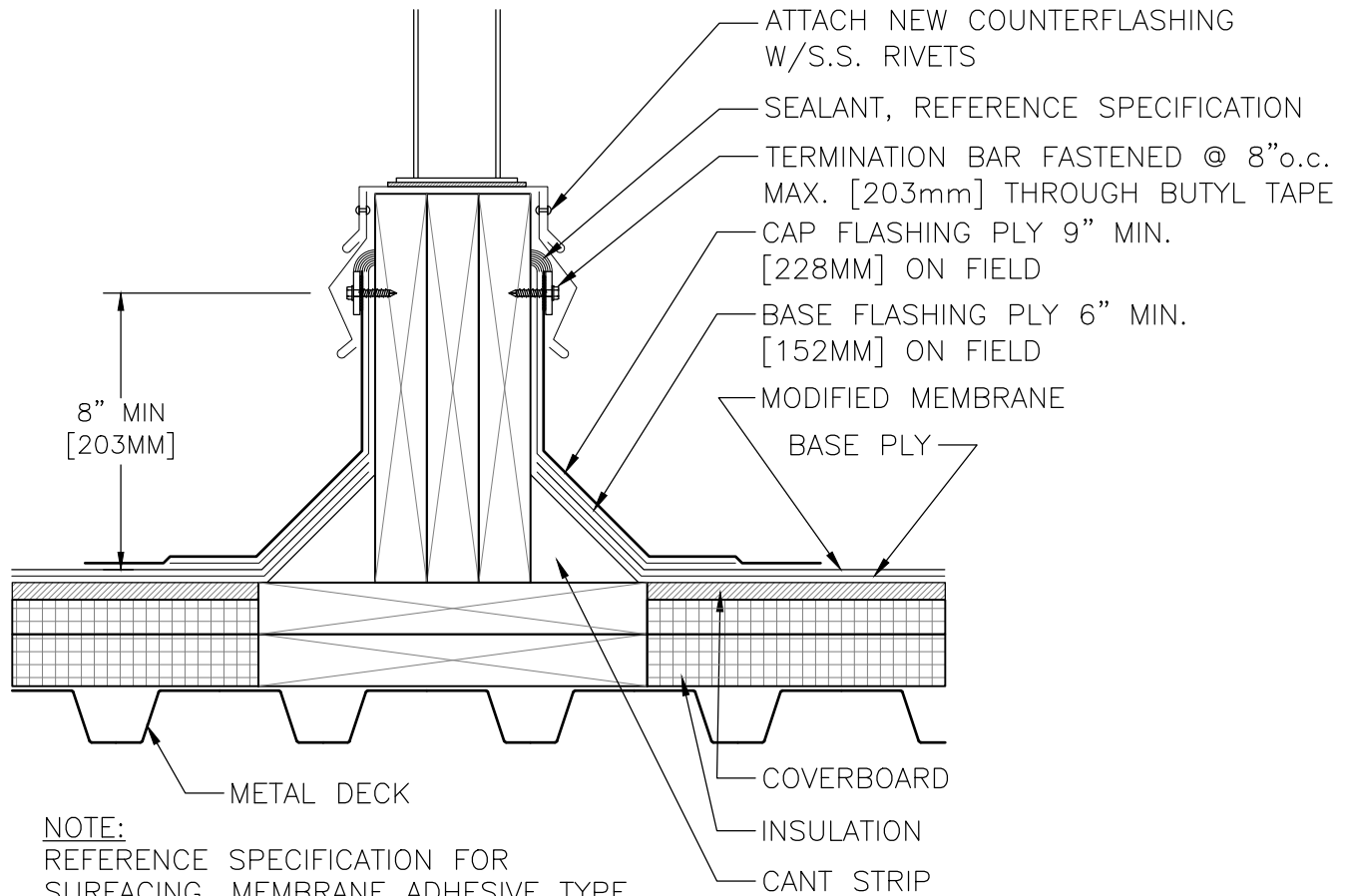

NOTE:
 REFERENCE SPECIFICATION FOR SURFACING, MEMBRANE ADHESIVE TYPE, AND INSULATION/COVER BOARD TYPE AND ATTACHMENT METHOD.

DRAWINGS ON 8½"x11 TITLE BLOCKS ARE NOT TO SCALE.

EQUIPMENT SUPPORT - EXISTING



THE GARLAND COMPANY, INC.
 GARLAND CANADA, INC.
 THE GARLAND COMPANY UK, LTD

PROJECT:	
CUSTOMER:	
ARCHITECT:	
REPRESENTATIVE:	
DATE:	SHT: OF

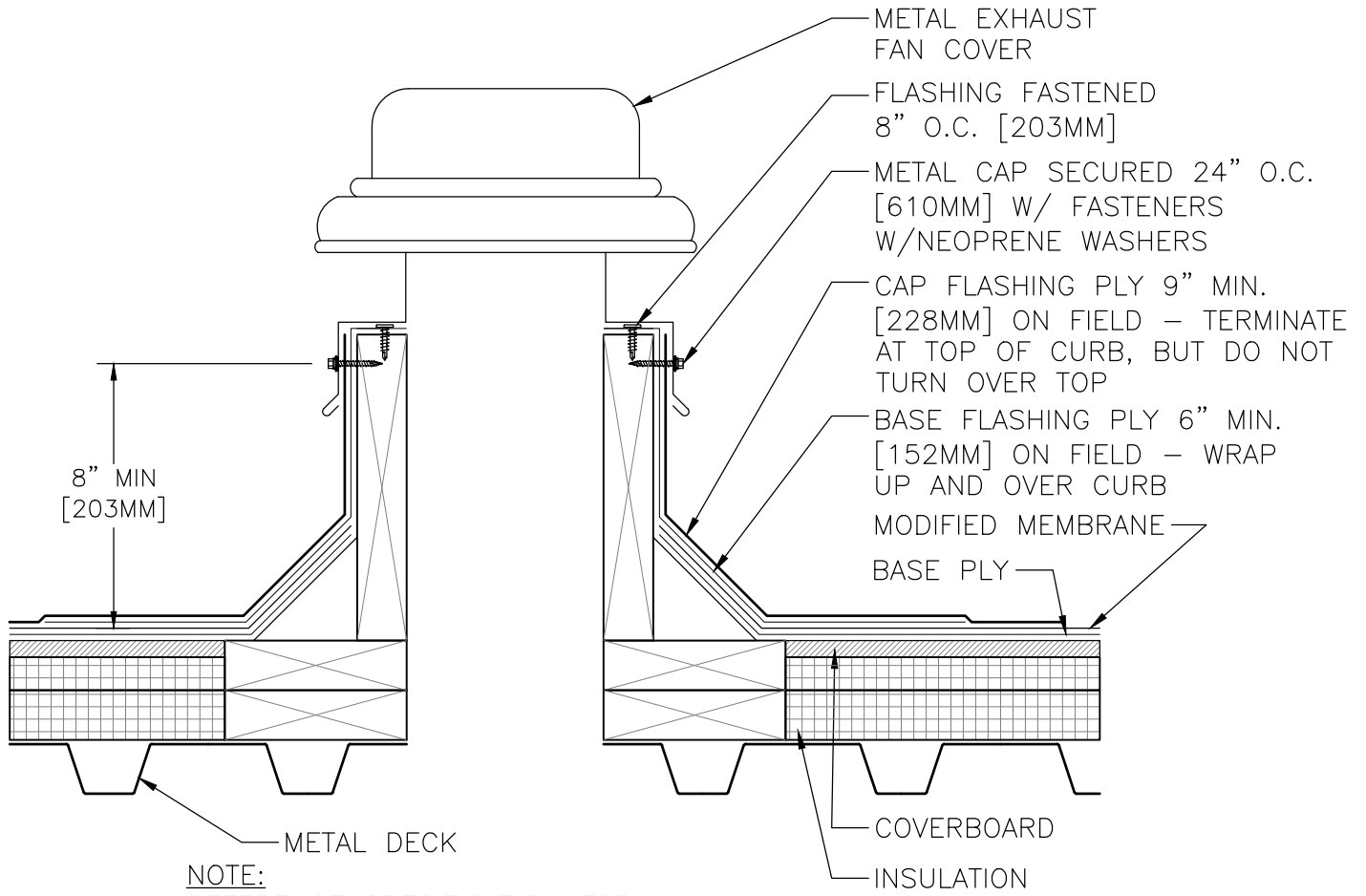

NOTE:
 REFERENCE SPECIFICATION FOR SURFACING, MEMBRANE ADHESIVE TYPE, AND INSULATION/COVER BOARD TYPE AND ATTACHMENT METHOD.

DRAWINGS ON 8½"x11 TITLE BLOCKS ARE NOT TO SCALE.

EXHAUST FAN



THE GARLAND COMPANY, INC.
 GARLAND CANADA, INC.
 THE GARLAND COMPANY UK, LTD

PROJECT:	
CUSTOMER:	
ARCHITECT:	
REPRESENTATIVE:	
DATE:	SHT: OF

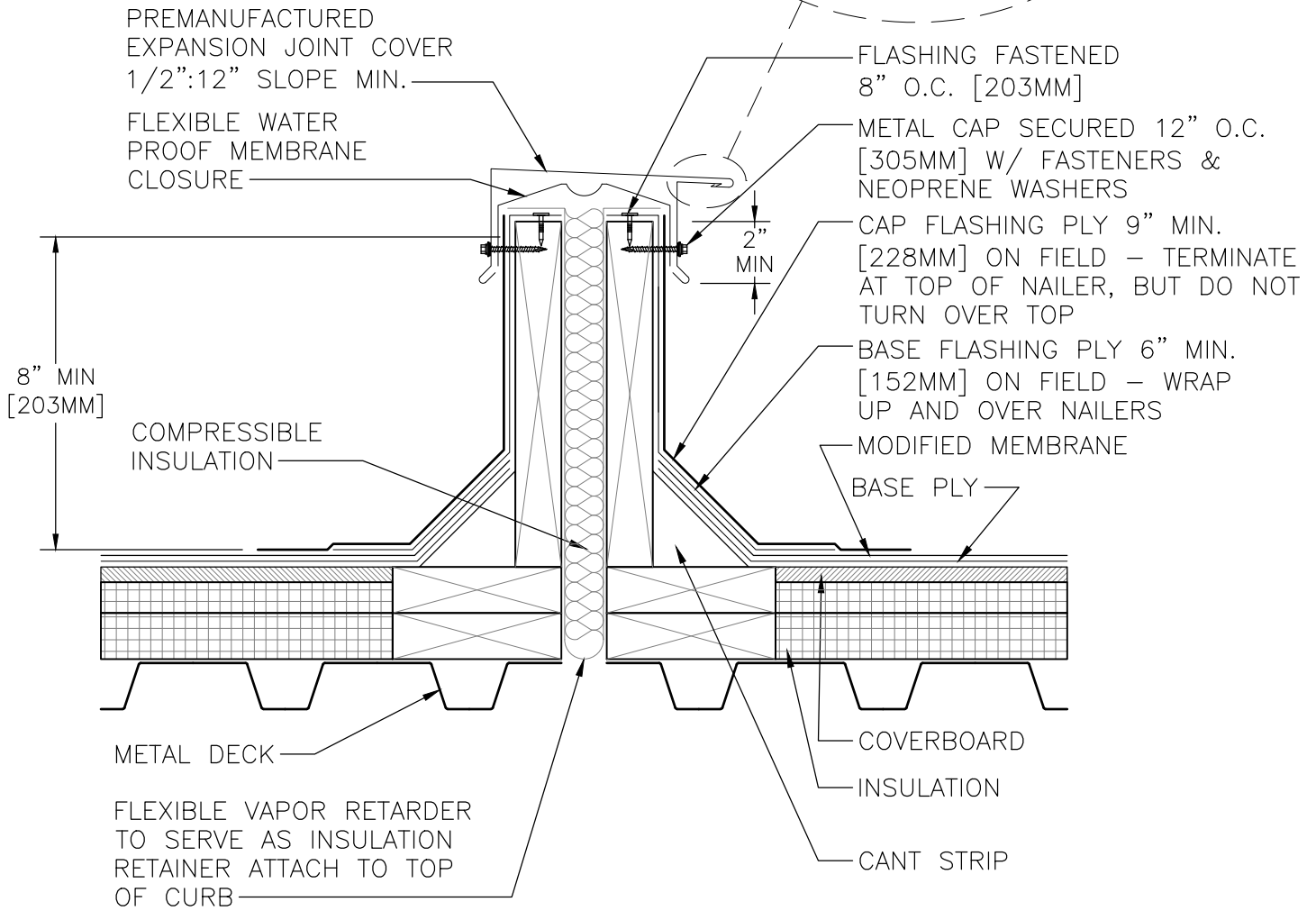
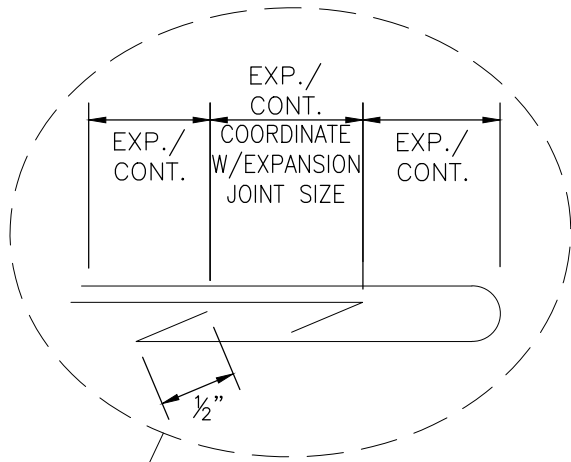

NOTE:
REFERENCE SPECIFICATION FOR SURFACING, MEMBRANE ADHESIVE TYPE, AND INSULATION/COVER BOARD TYPE AND ATTACHMENT METHOD.

DRAWINGS ON 8 1/2"x11 TITLE BLOCKS ARE NOT TO SCALE.

EXPANSION JOINT



THE GARLAND COMPANY, INC.
GARLAND CANADA, INC.
THE GARLAND COMPANY UK, LTD

PROJECT:	
CUSTOMER:	
ARCHITECT:	
REPRESENTATIVE:	
DATE:	SHT: OF

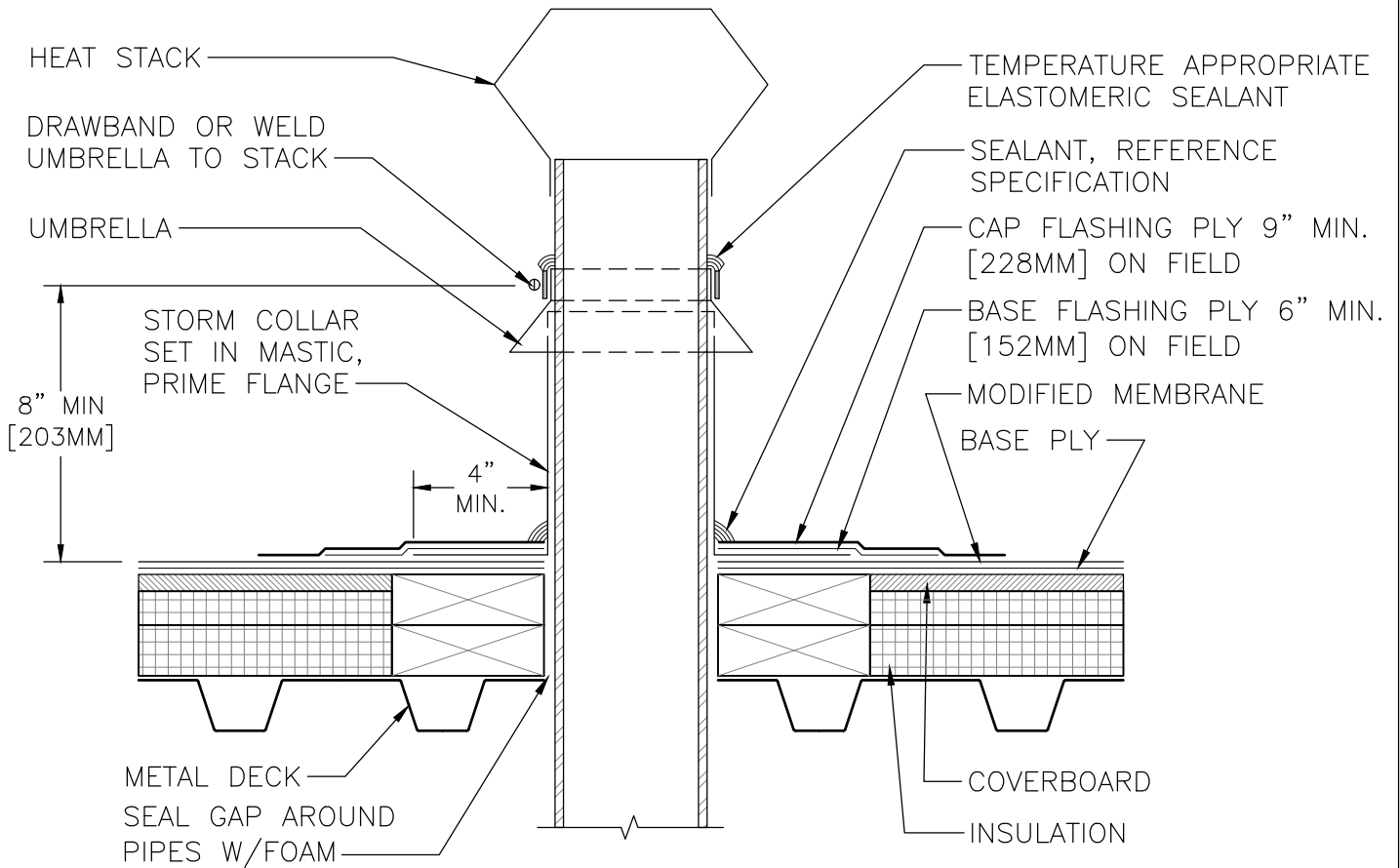

NOTE:
 REFERENCE SPECIFICATION FOR
 SURFACING, MEMBRANE ADHESIVE TYPE,
 AND INSULATION/COVER BOARD TYPE
 AND ATTACHMENT METHOD.

DRAWINGS ON 8½"x11 TITLE BLOCKS ARE NOT TO SCALE.

HEAT STACK



THE GARLAND COMPANY, INC.
 GARLAND CANADA, INC.
 THE GARLAND COMPANY UK, LTD

PROJECT:	
CUSTOMER:	
ARCHITECT:	
REPRESENTATIVE:	
DATE:	SHT: OF

PREPARE AND PRIME
PROJECTION

SEALANT, REFERENCE
SPECIFICATION

DRAWBAND

WATERTIGHT SHEET METAL
RAIN COLLAR OVERLAPPING
PENETRATION POCKET

POURABLE SEALANT,
2 PART, 2" MIN.

NON-SHRINK GROUT,
2" MIN.

4"
MIN.

METAL DECK
SEAL GAP AROUND
PIPES W/FOAM

SHEET METAL PITCH PAN
SOLDERED/WELDED WATERTIGHT
4" MIN [102MM] HEIGHT

SEALANT, REFERENCE
SPECIFICATION

CAP FLASHING PLY 9" MIN.
[228MM] ON FIELD

BASE FLASHING PLY 6" MIN.
[152MM] ON FIELD

MODIFIED MEMBRANE
BASE PLY

COVERBOARD

INSULATION

OPT: WOOD NAILERS; VARIES
DEPENDING UPON SIZE OF
PENETRATION

NOTE:
REFERENCE SPECIFICATION FOR
SURFACING, MEMBRANE ADHESIVE TYPE,
AND INSULATION/COVER BOARD TYPE
AND ATTACHMENT METHOD.

DRAWINGS ON 8½"x11 TITLE BLOCKS ARE NOT TO SCALE.

PITCH POCKET (PIPE)



THE GARLAND COMPANY, INC.
GARLAND CANADA, INC.
THE GARLAND COMPANY UK, LTD

PROJECT:	
CUSTOMER:	
ARCHITECT:	
REPRESENTATIVE:	
DATE:	SHT: OF

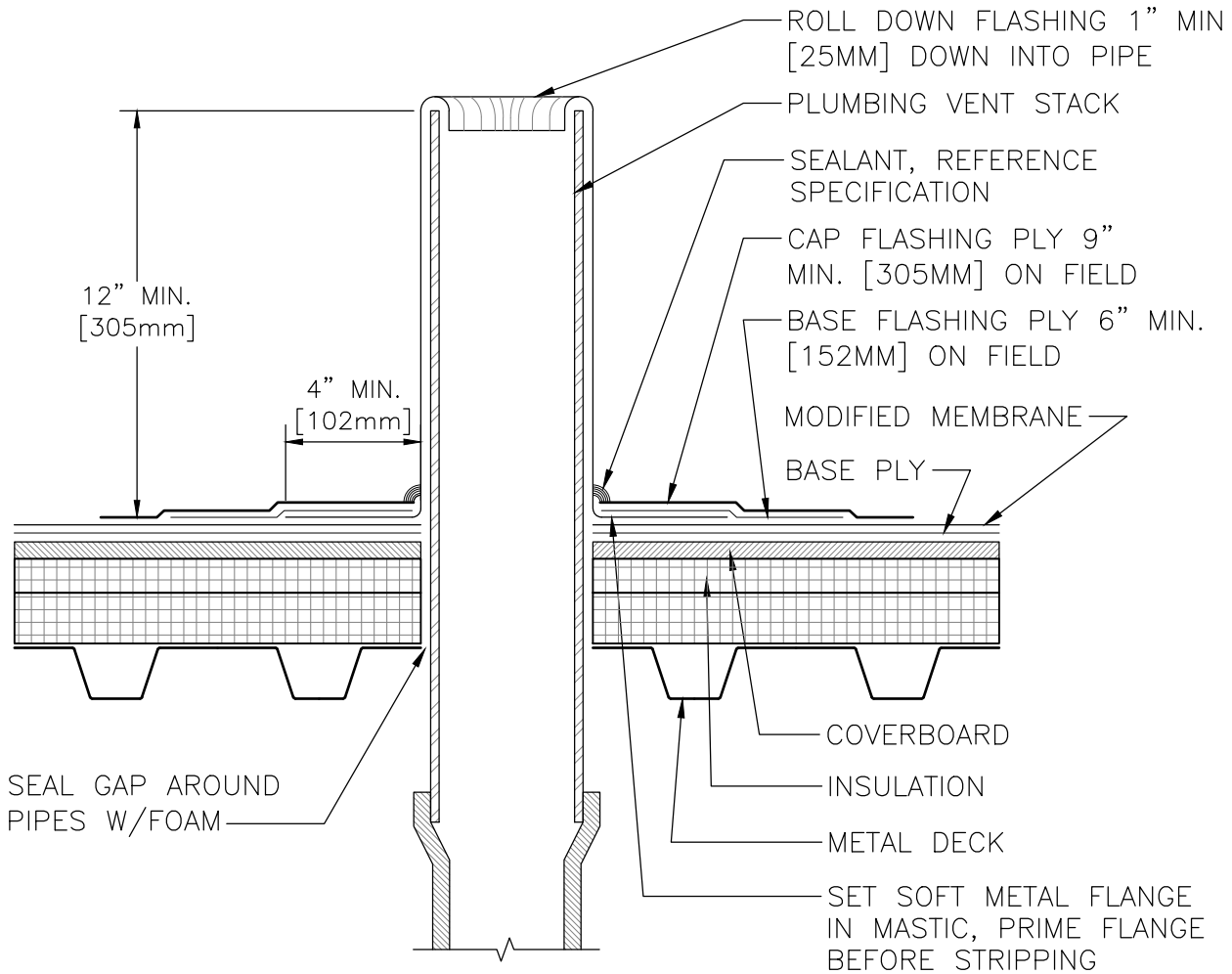

NOTE:
 REFERENCE SPECIFICATION FOR SURFACING, MEMBRANE ADHESIVE TYPE, AND INSULATION/COVER BOARD TYPE AND ATTACHMENT METHOD.

DRAWINGS ON 8½"x11 TITLE BLOCKS ARE NOT TO SCALE.

PLUMBING STACK



THE GARLAND COMPANY, INC.
 GARLAND CANADA, INC.
 THE GARLAND COMPANY UK, LTD

PROJECT:	
CUSTOMER:	
ARCHITECT:	
REPRESENTATIVE:	
DATE:	SHT: OF

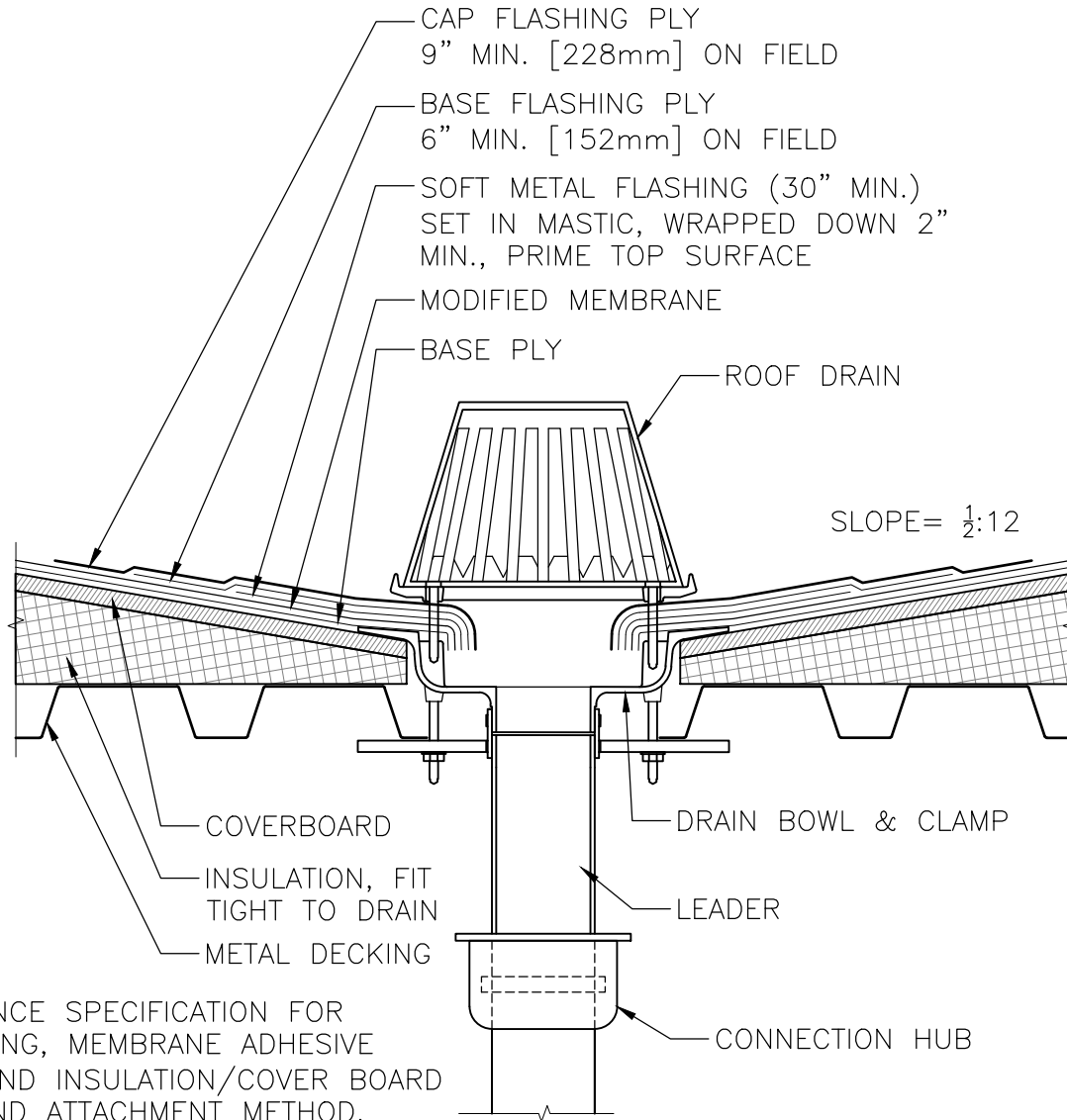

NOTE:
 REFERENCE SPECIFICATION FOR SURFACING, MEMBRANE ADHESIVE TYPE, AND INSULATION/COVER BOARD TYPE AND ATTACHMENT METHOD.

DRAWINGS ON 8½"x11 TITLE BLOCKS ARE NOT TO SCALE.

ROOF DRAIN



THE GARLAND COMPANY, INC.
 GARLAND CANADA, INC.
 THE GARLAND COMPANY UK, LTD

PROJECT:	
CUSTOMER:	
ARCHITECT:	
REPRESENTATIVE:	
DATE:	SHT: OF

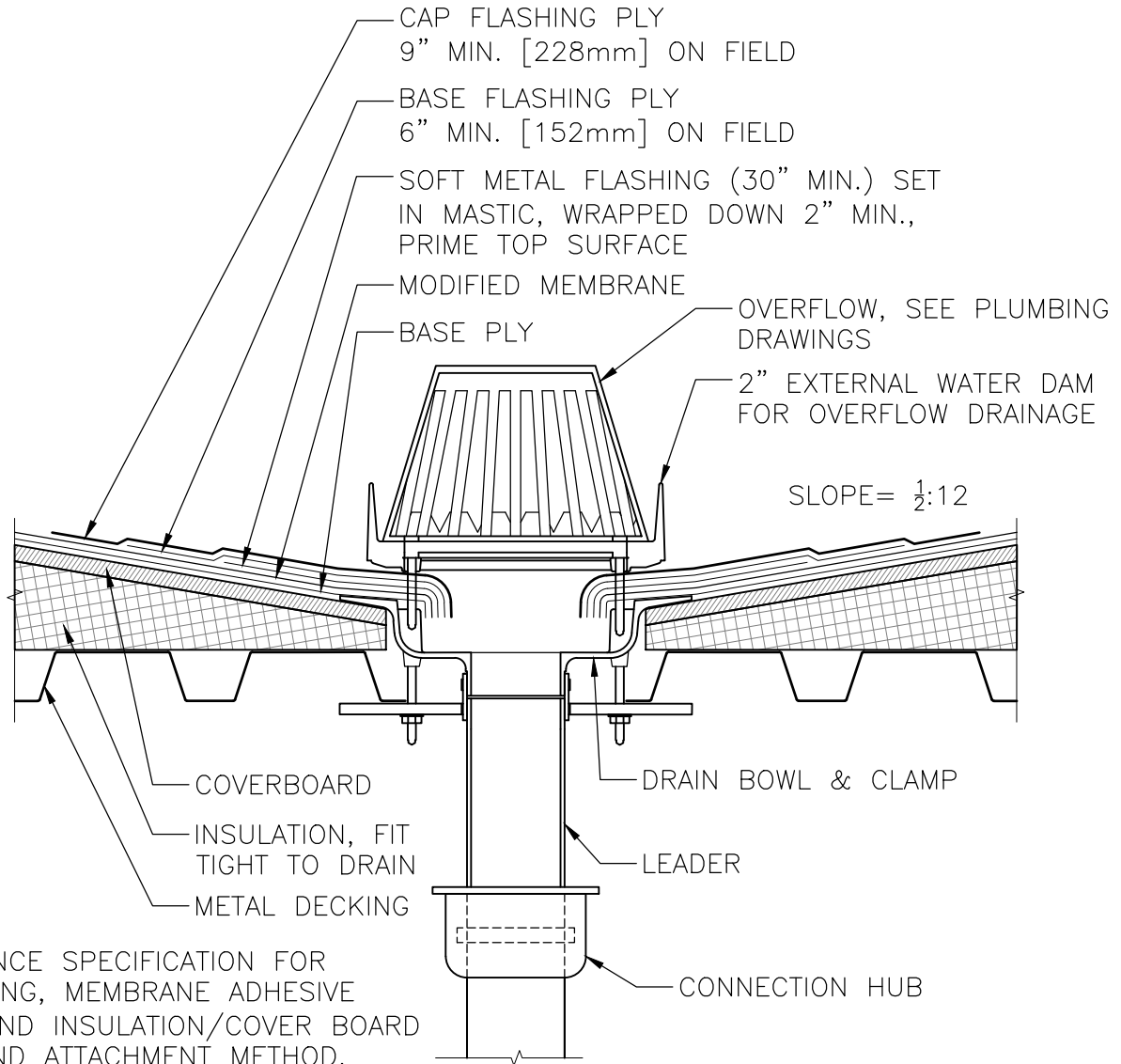

NOTE:
REFERENCE SPECIFICATION FOR
SURFACING, MEMBRANE ADHESIVE
TYPE, AND INSULATION/COVER BOARD
TYPE AND ATTACHMENT METHOD.

DRAWINGS ON 8 1/2"x11 TITLE BLOCKS ARE NOT TO SCALE.

ROOF DRAIN - OVERFLOW



THE GARLAND COMPANY, INC.
GARLAND CANADA, INC.
THE GARLAND COMPANY UK, LTD

PROJECT:	
CUSTOMER:	
ARCHITECT:	
REPRESENTATIVE:	
DATE:	SHT: OF

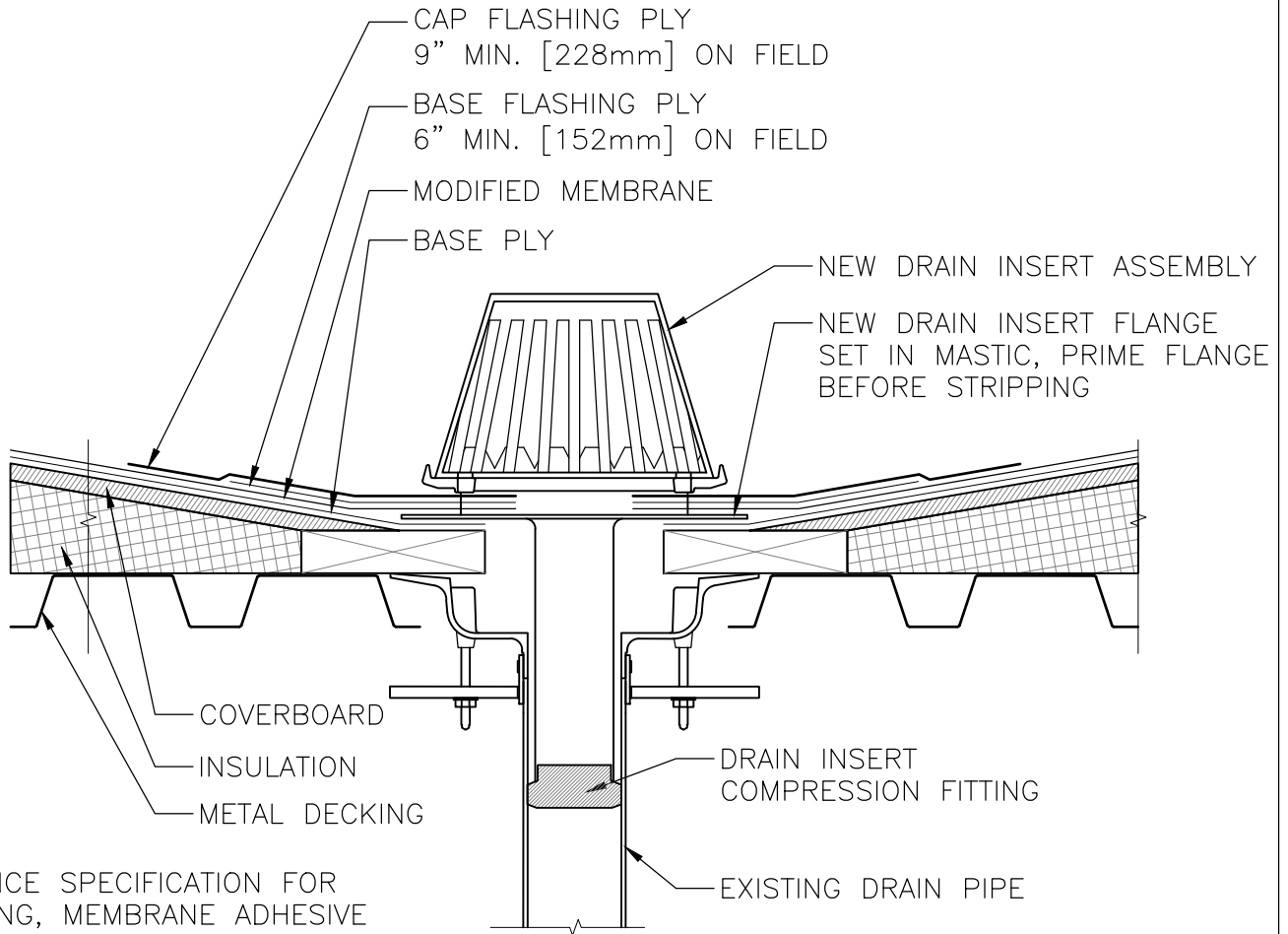

NOTE:
REFERENCE SPECIFICATION FOR
SURFACING, MEMBRANE ADHESIVE
TYPE, AND INSULATION/COVER BOARD
TYPE AND ATTACHMENT METHOD.

DRAWINGS ON 8½"x11 TITLE BLOCKS ARE NOT TO SCALE.

ROOF DRAIN RETROFIT



THE GARLAND COMPANY, INC.
GARLAND CANADA, INC.
THE GARLAND COMPANY UK, LTD

PROJECT:	
CUSTOMER:	
ARCHITECT:	
REPRESENTATIVE:	
DATE:	SHT: OF

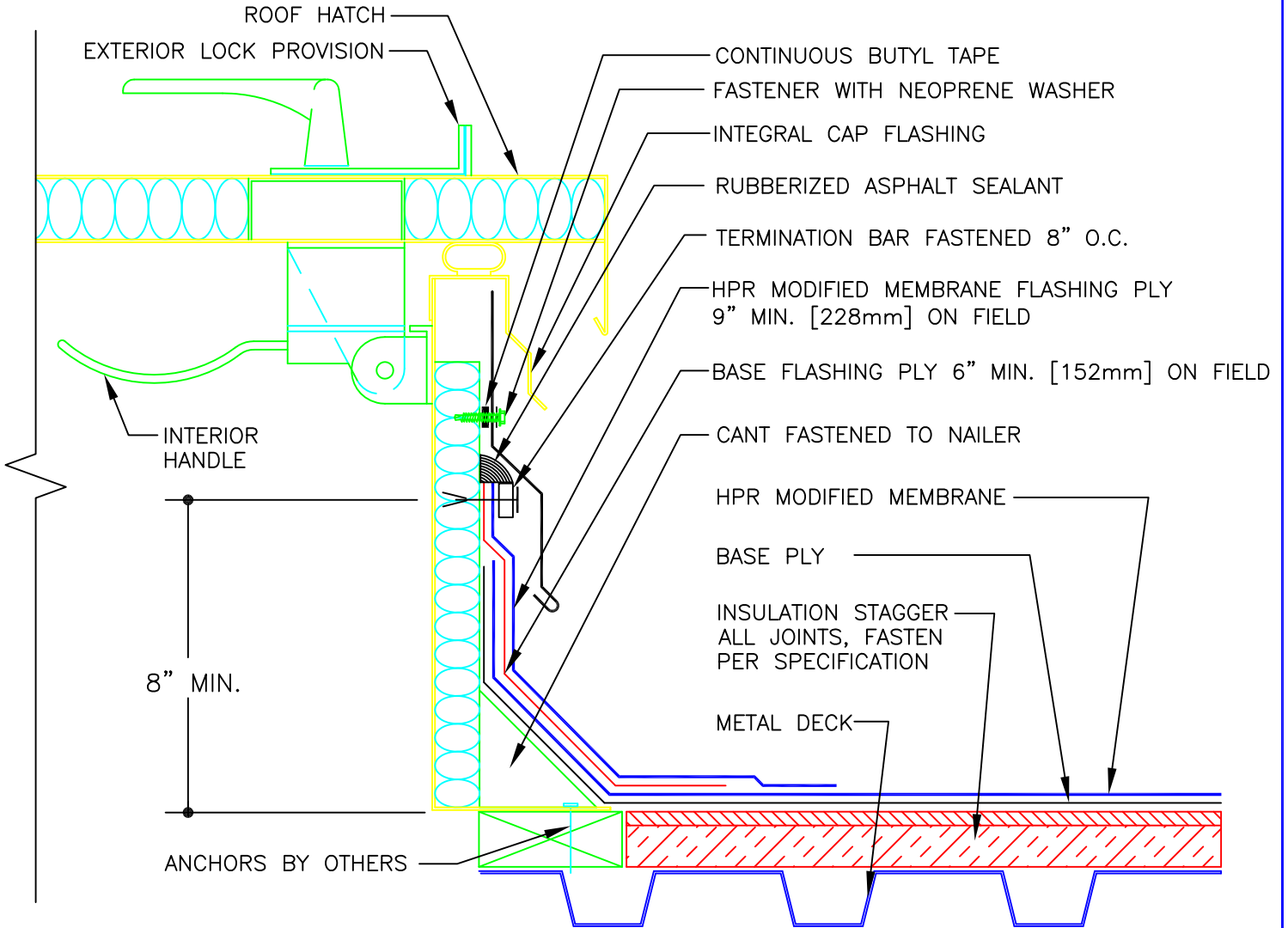

ALL PLYS SET IN MODIFIED COLD ADHESIVE
SEE SPECIFICATIONS FOR SURFACING



THE GARLAND COMPANY, INC.
GARLAND CANADA, INC.
THE GARLAND COMPANY UK, LTD

DETAIL:

ROOF HATCH

2 PLY-COLD APPLIED

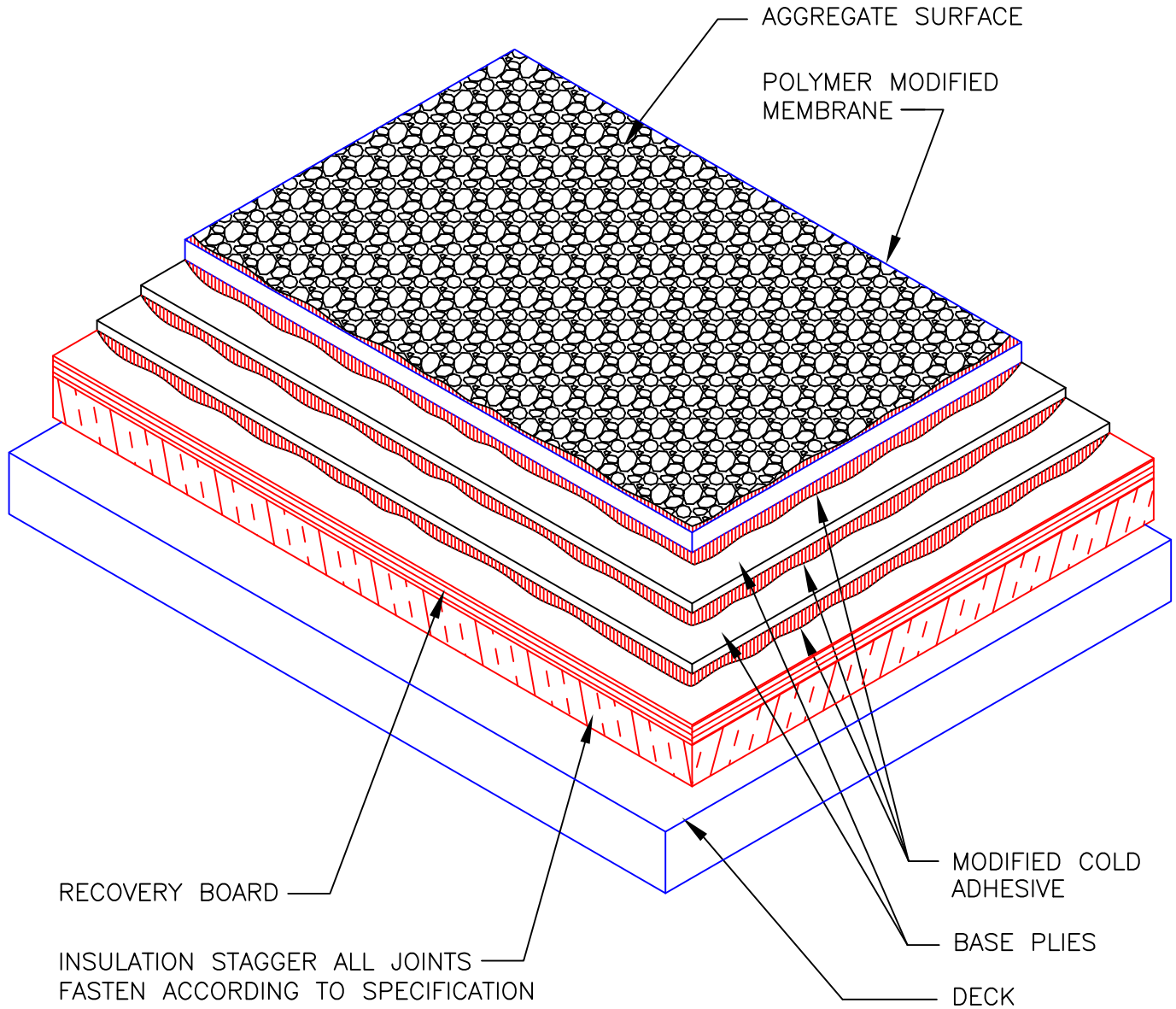

ALL PLYS SET IN MODIFIED COLD ADHESIVE SEE SPECIFICATIONS FOR SURFACING



THE GARLAND COMPANY, INC.
 GARLAND CANADA, INC.
 THE GARLAND COMPANY UK, LTD

DETAIL:

GRAVEL FINISH

COLD APPLIED

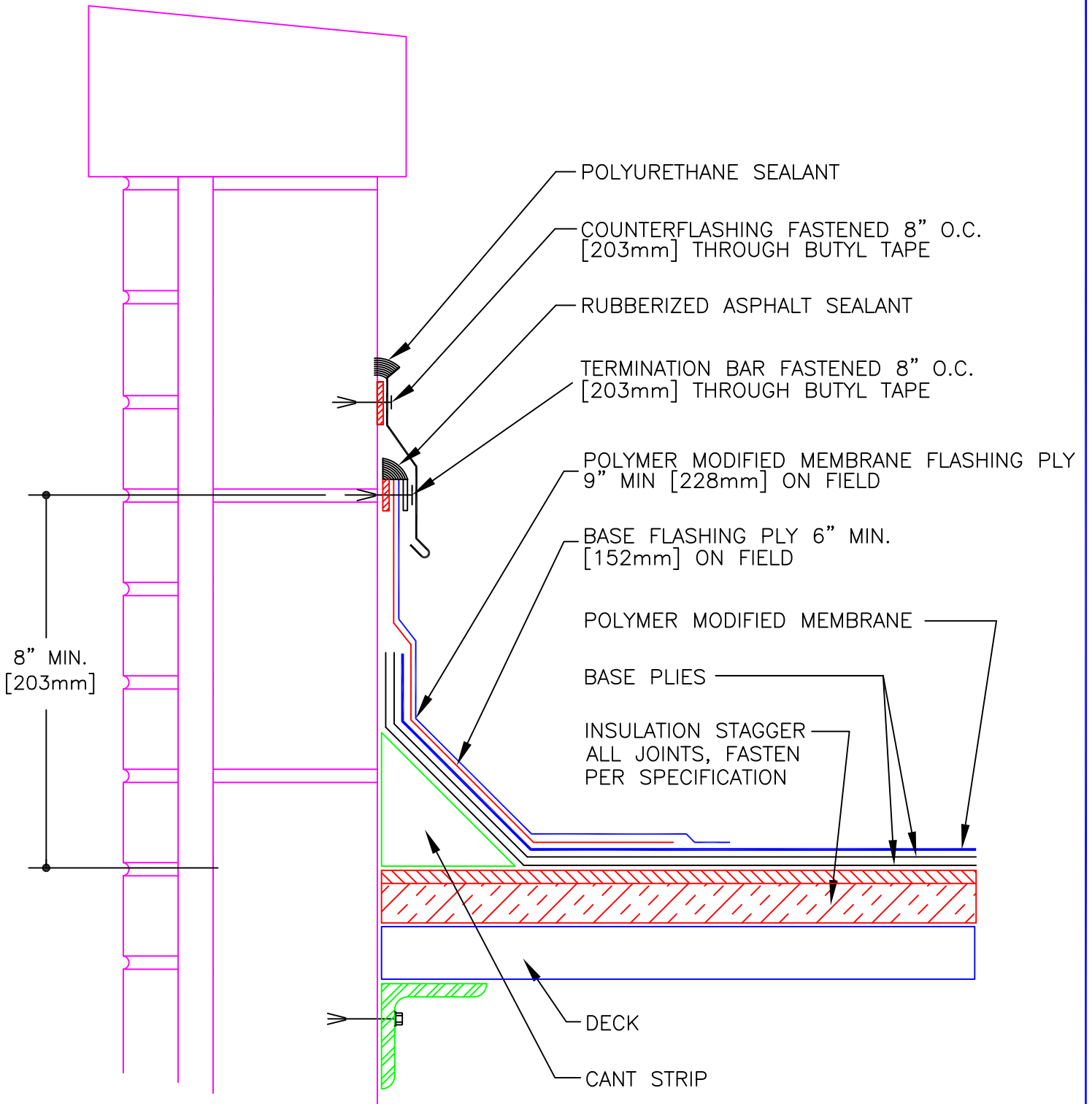

ALL PLYES SET IN MODIFIED COLD ADHESIVE SEE SPECIFICATIONS FOR SURFACING



THE GARLAND COMPANY, INC.

GARLAND CANADA, INC.

THE GARLAND COMPANY UK, LTD

DETAIL:

SURFACE MOUNTED COUNTERFLASHING

COLD APPLIED

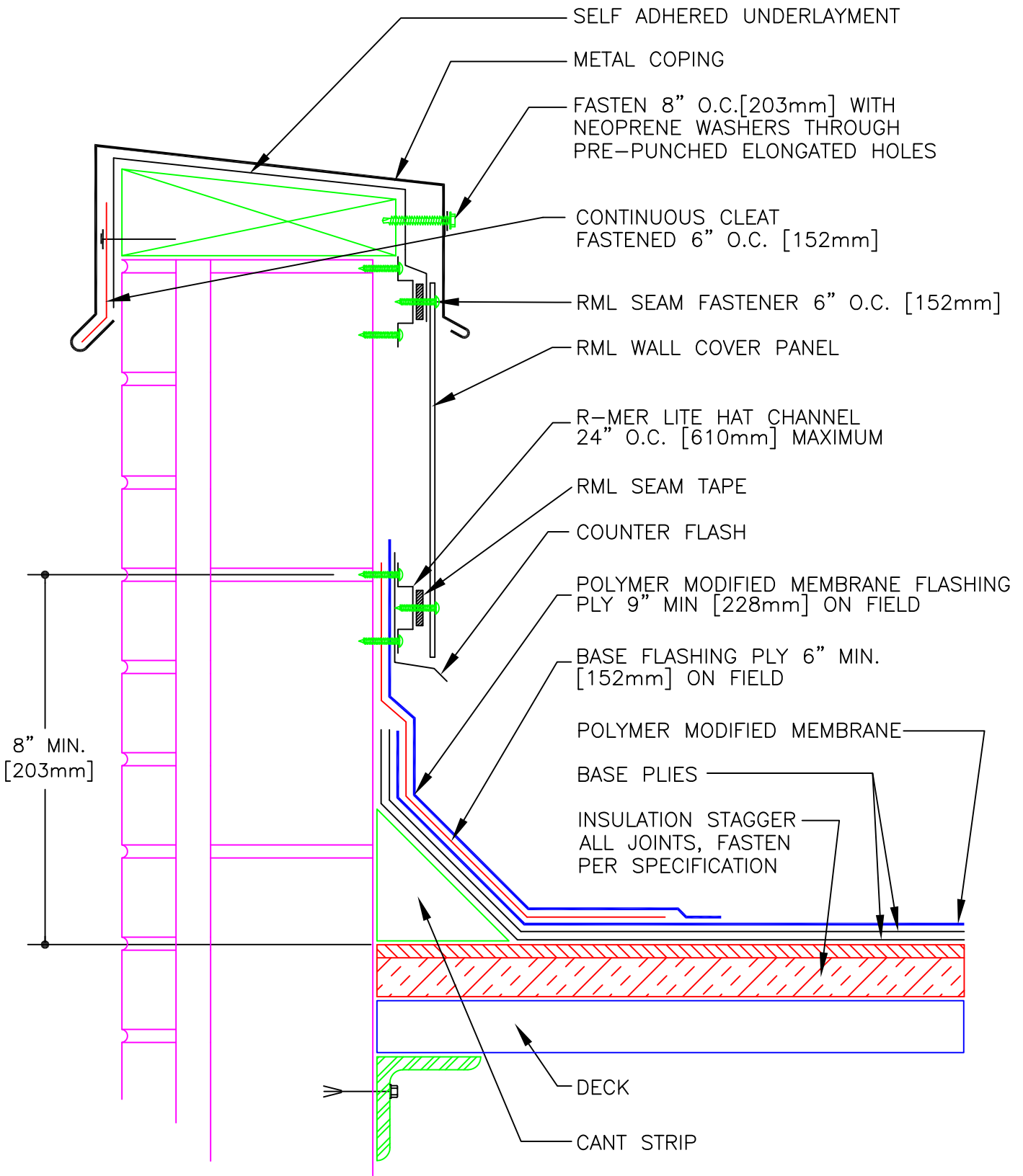

ALL PLYS SET IN MODIFIED COLD ADHESIVE SEE SPECIFICATIONS FOR SURFACING



THE GARLAND COMPANY, INC.
 GARLAND CANADA, INC.
 THE GARLAND COMPANY UK, LTD

DETAIL:

RML WALL PANEL W. MOD. BITUMEN ROOF FLASHING

COLD APPLIED

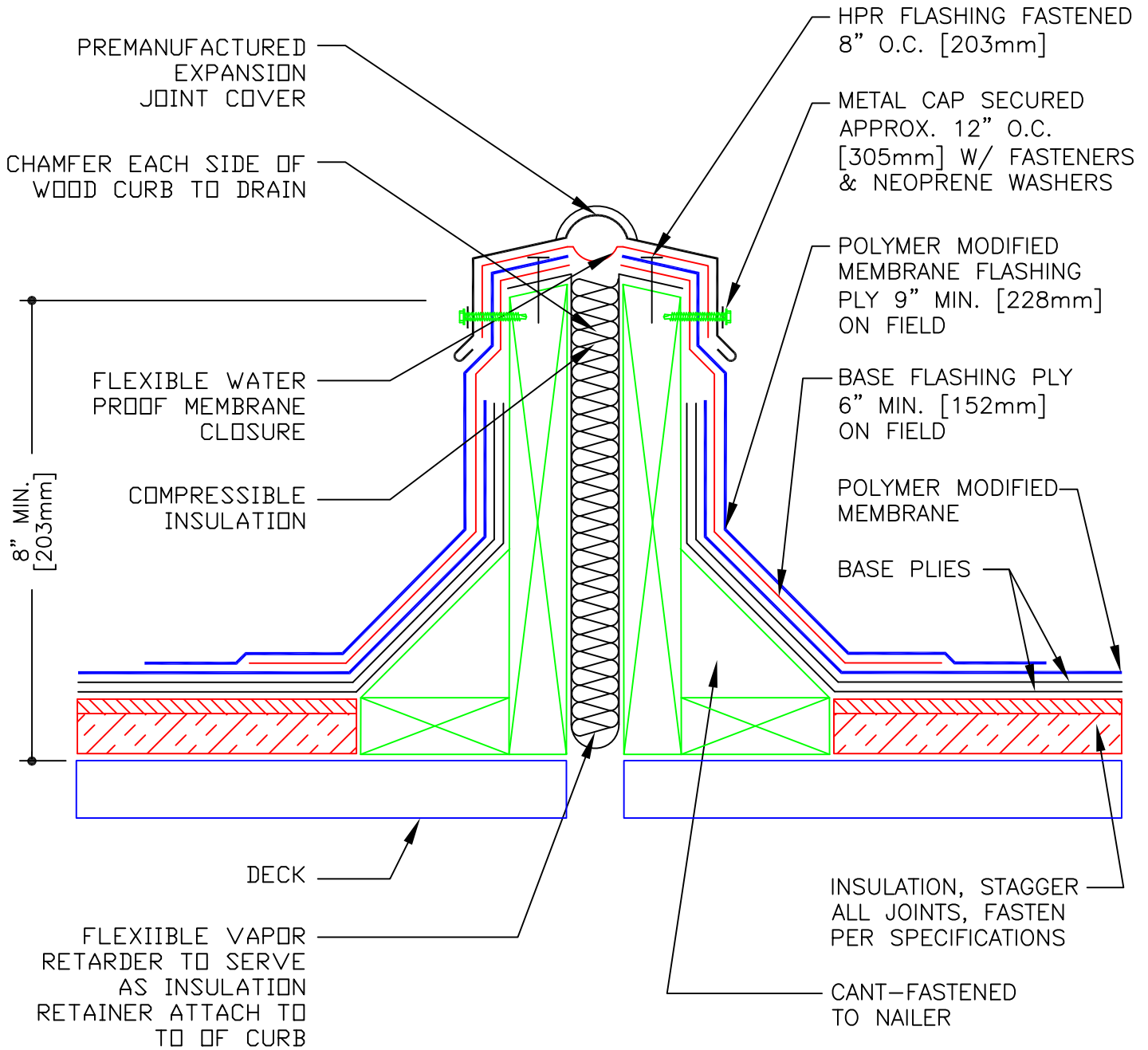

ALL PLIES SET IN MODIFIED COLD ADHESIVE SEE SPECIFICATIONS FOR SURFACING



THE GARLAND COMPANY, INC.
 GARLAND CANADA, INC.
 THE GARLAND COMPANY UK, LTD

DETAIL:

EXPANSION JOINT

COLD APPLIED

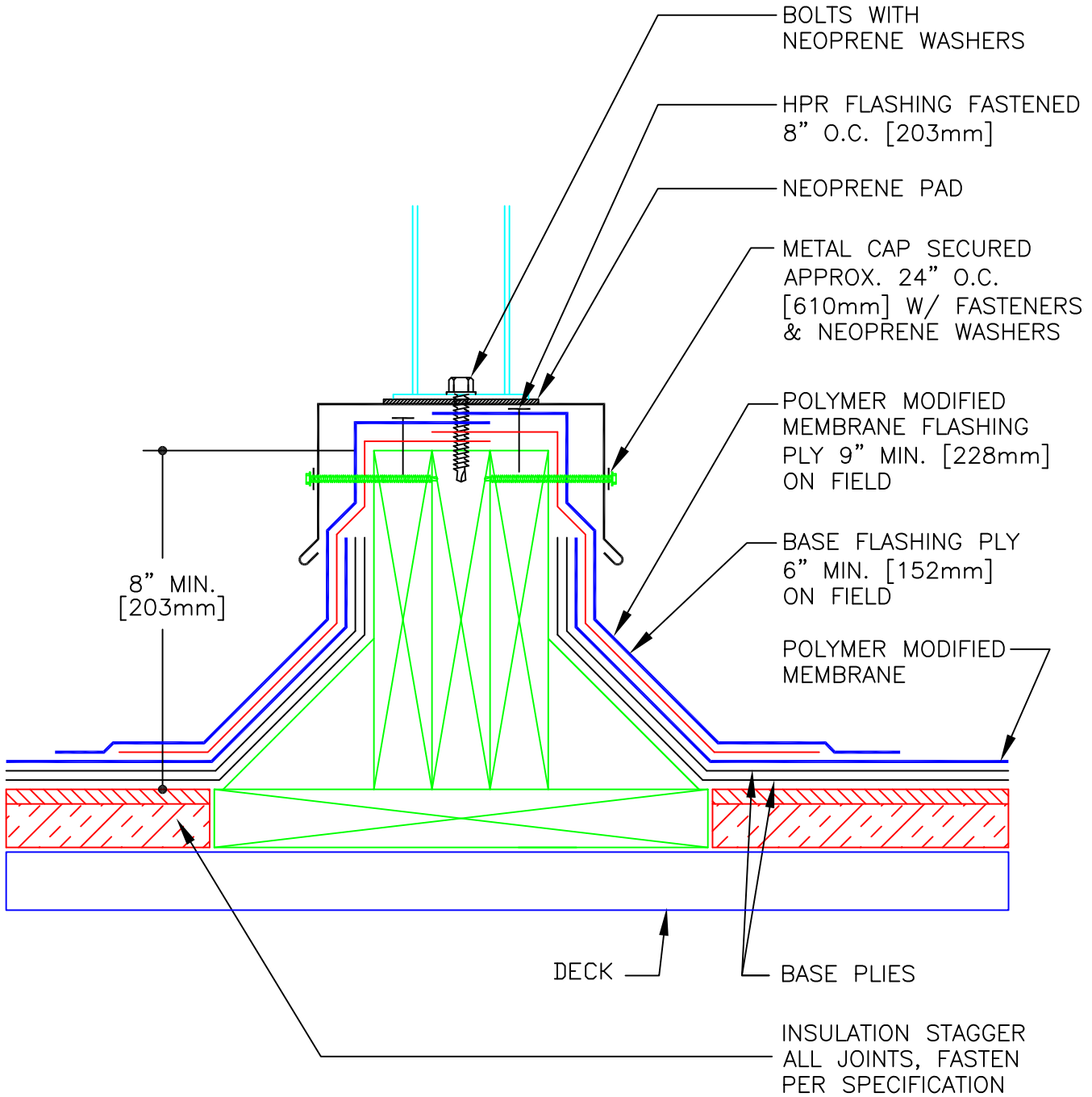

ALL PLIES SET IN MODIFIED COLD ADHESIVE SEE SPECIFICATIONS FOR SURFACING



THE GARLAND COMPANY, INC.
 GARLAND CANADA, INC.
 THE GARLAND COMPANY UK, LTD

DETAIL:

EQUIPMENT SUPPORT

COLD APPLIED

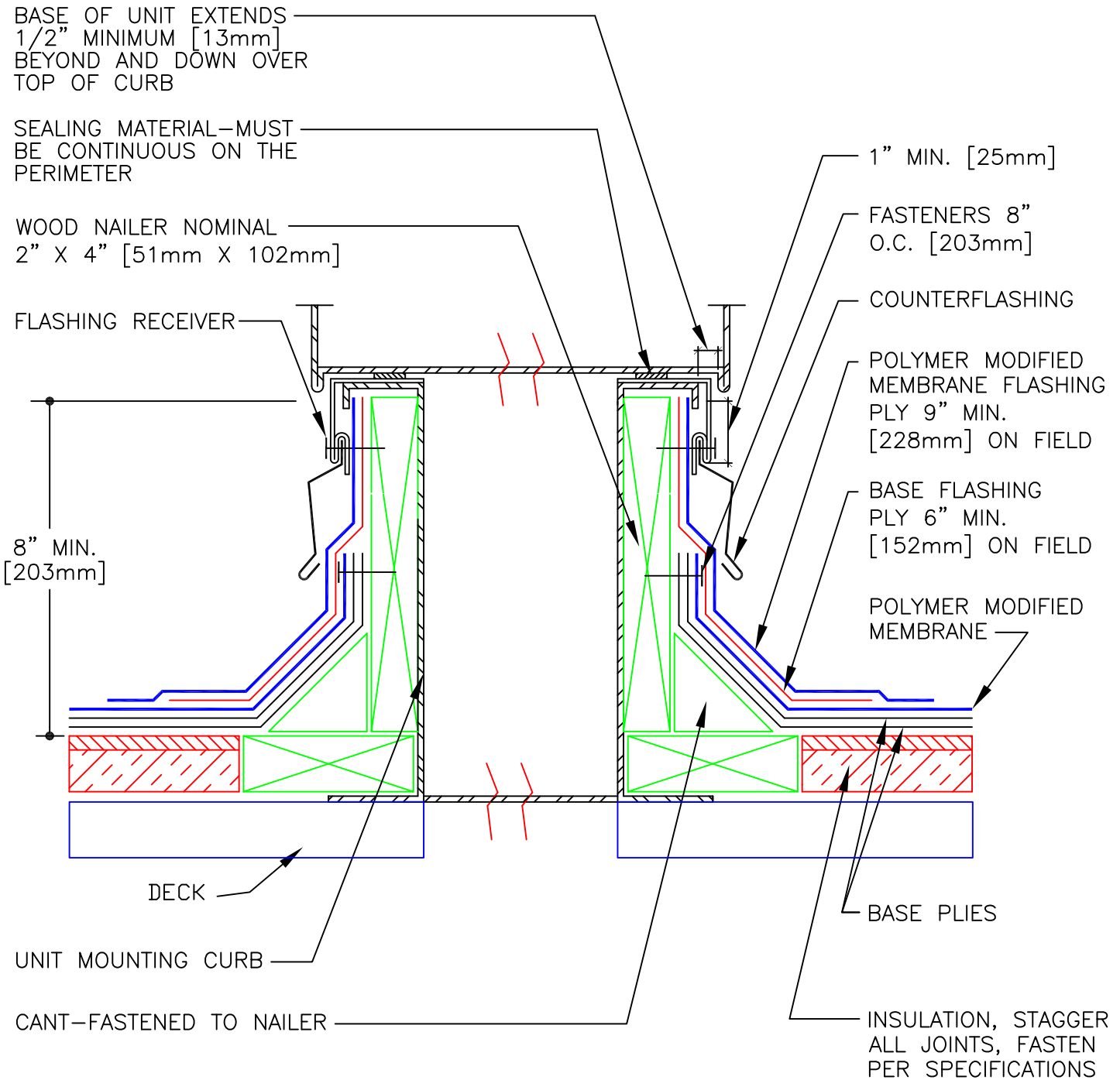

ALL PLYS SET IN MODIFIED COLD
ADHESIVE SEE SPECIFICATIONS FOR SURFACING



THE GARLAND COMPANY, INC.
GARLAND CANADA, INC.
THE GARLAND COMPANY UK, LTD

DETAIL:

CURB DETAIL/AIR HANDLING STATION

COLD APPLIED

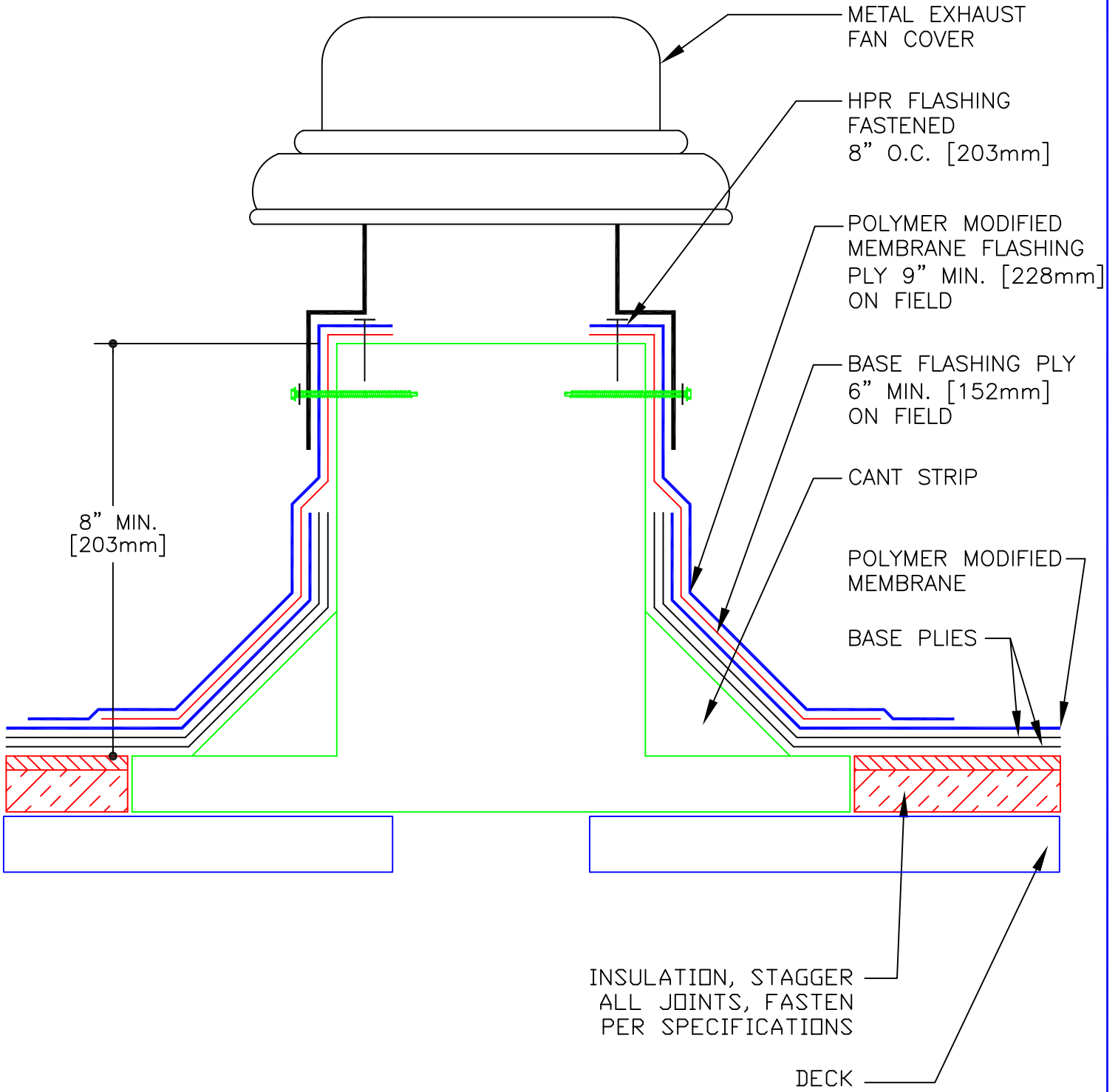

ALL PLIES SET IN MODIFIED COLD ADHESIVE SEE SPECIFICATIONS FOR SURFACING



THE GARLAND COMPANY, INC.
 GARLAND CANADA, INC.
 THE GARLAND COMPANY UK, LTD

DETAIL:

EXHAUST FAN DETAIL

COLD APPLIED

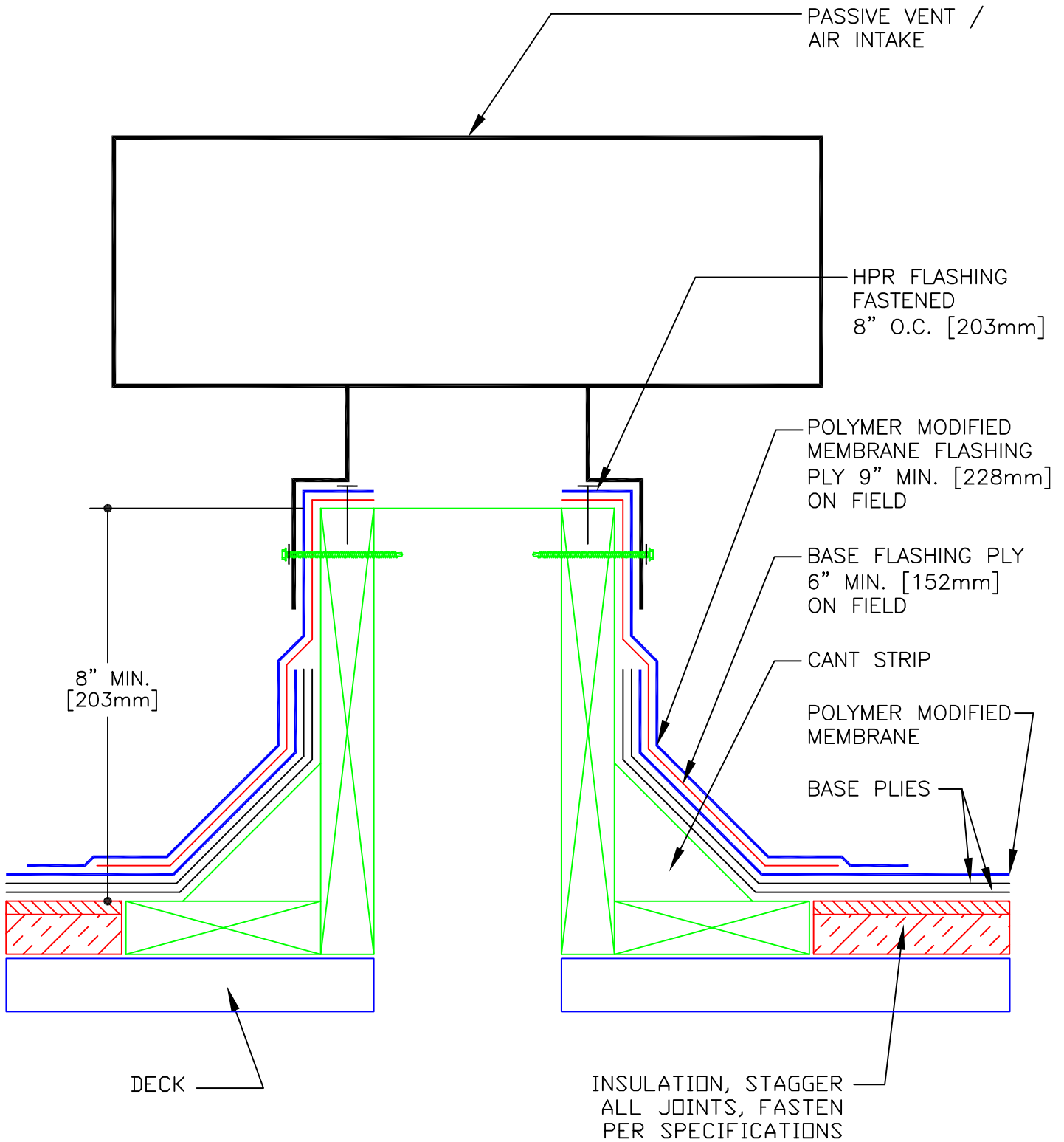

ALL PLIES SET IN MODIFIED COLD ADHESIVE SEE SPECIFICATIONS FOR SURFACING



THE GARLAND COMPANY, INC.
 GARLAND CANADA, INC.
 THE GARLAND COMPANY UK, LTD

DETAIL:

PASSIVE VENT/AIR INTAKE

COLD APPLIED

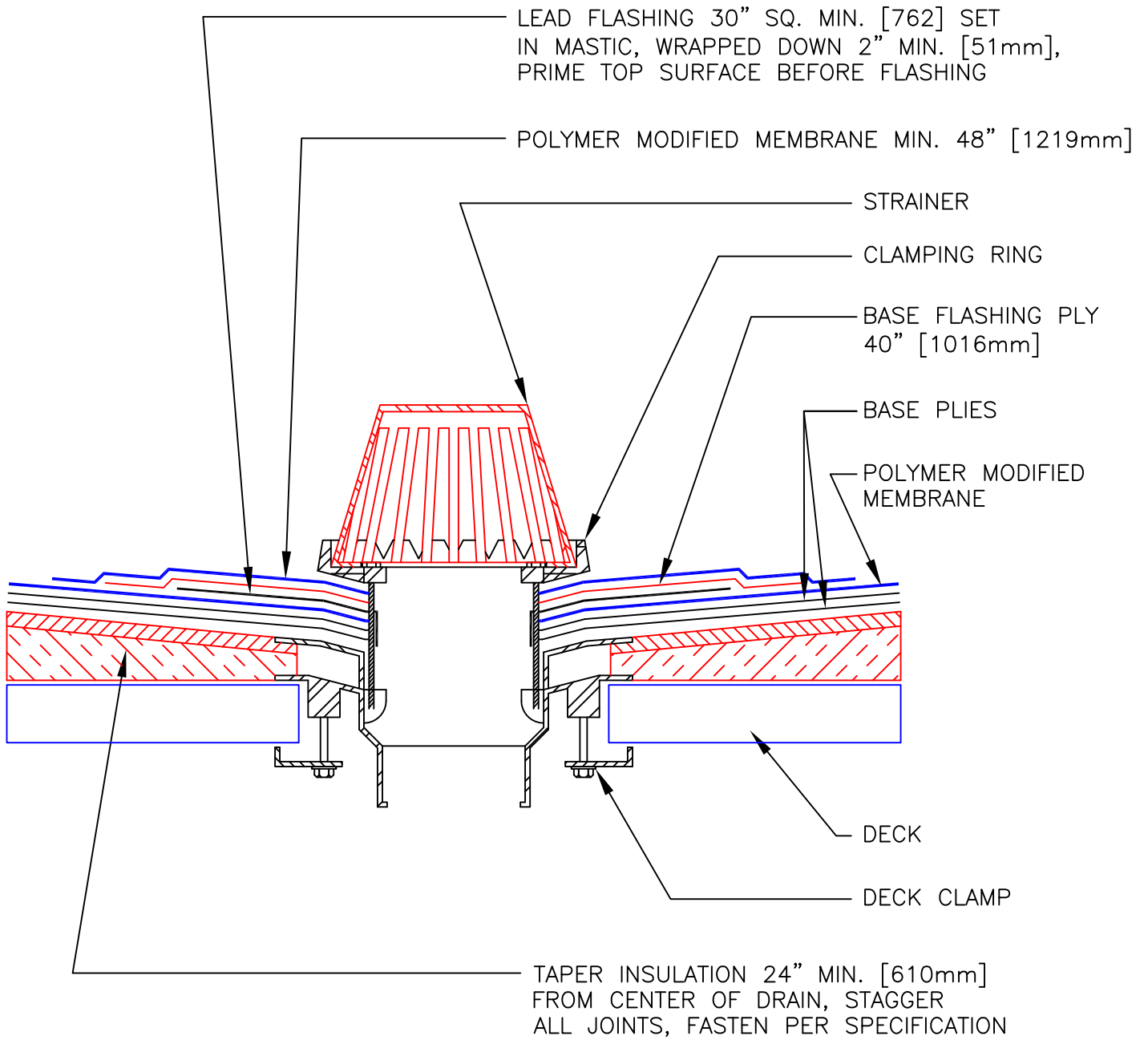

ALL PLYS SET IN MODIFIED COLD ADHESIVE SEE SPECIFICATIONS FOR SURFACING



THE GARLAND COMPANY, INC.
 GARLAND CANADA, INC.
 THE GARLAND COMPANY UK, LTD

DETAIL:

ROOF DRAIN

COLD APPLIED

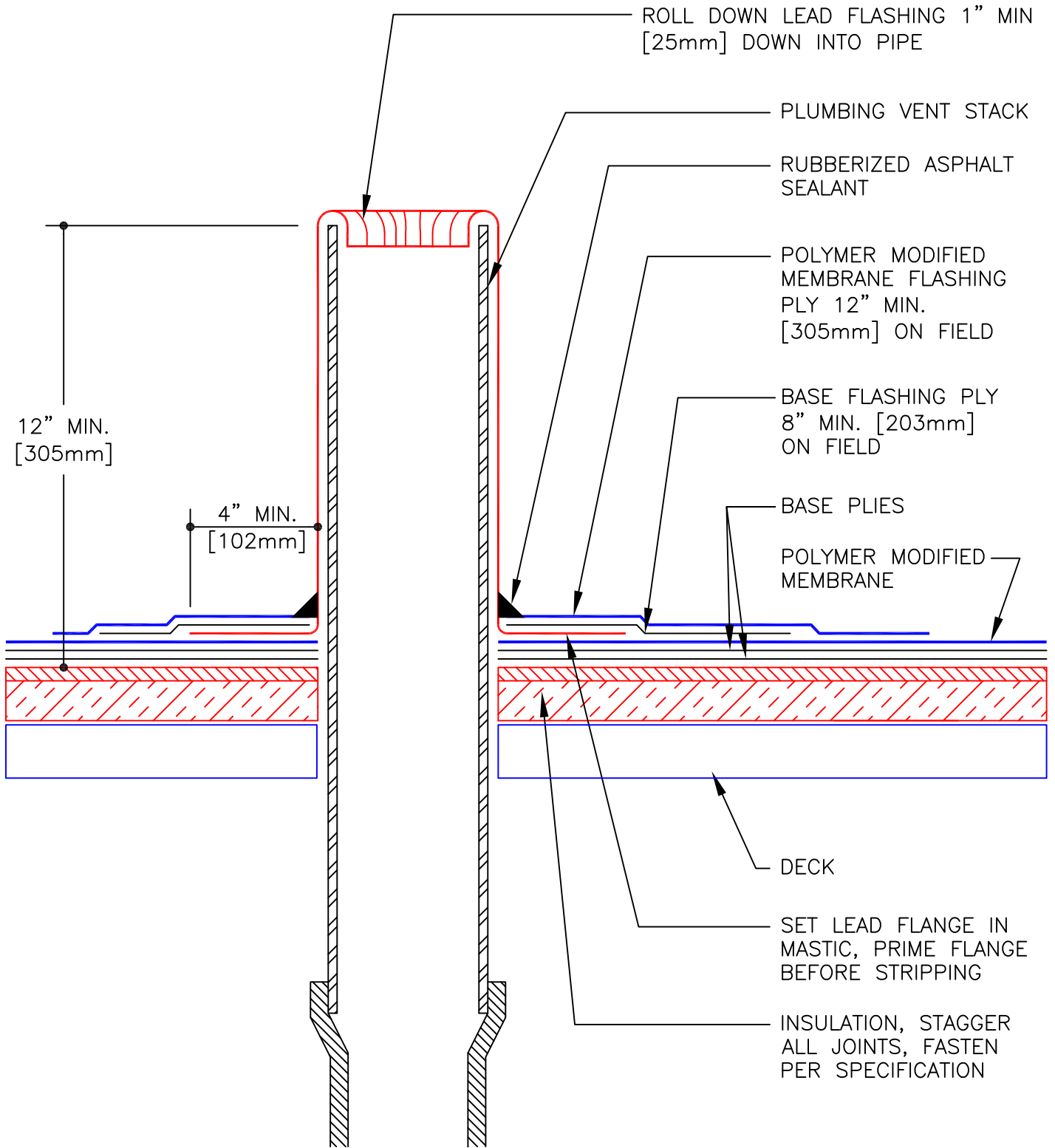

ALL PLIES SET IN MODIFIED COLD ADHESIVE SEE SPECIFICATIONS FOR SURFACING



THE GARLAND COMPANY, INC.
 GARLAND CANADA, INC.
 THE GARLAND COMPANY UK, LTD

DETAIL:

PLUMBING STACK

COLD APPLIED

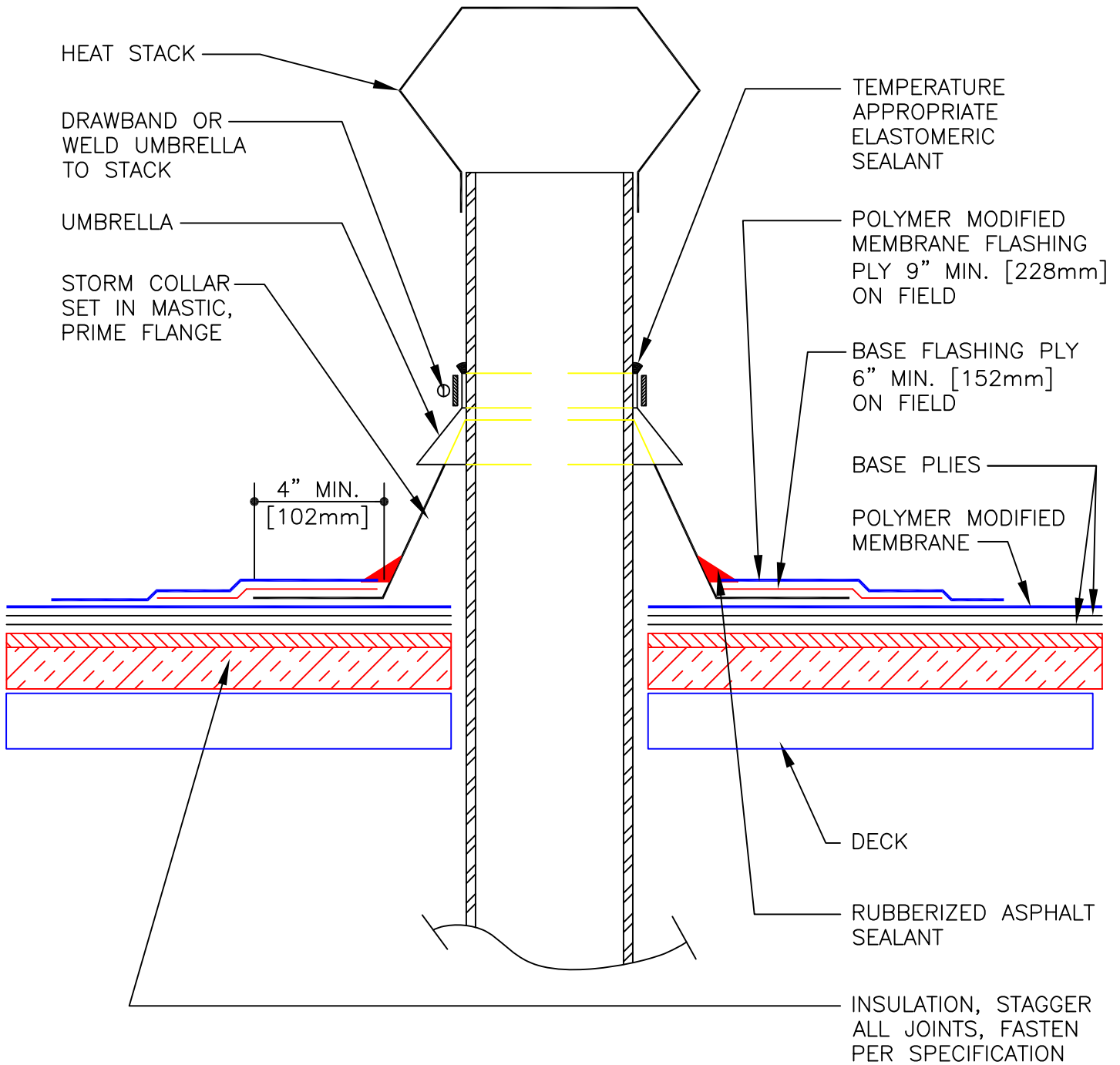

ALL PLIES SET IN MODIFIED COLD ADHESIVE SEE SPECIFICATIONS FOR SURFACING



THE GARLAND COMPANY, INC.
GARLAND CANADA, INC.
THE GARLAND COMPANY UK, LTD

DETAIL:

H E A T S T A C K

COLD APPLIED

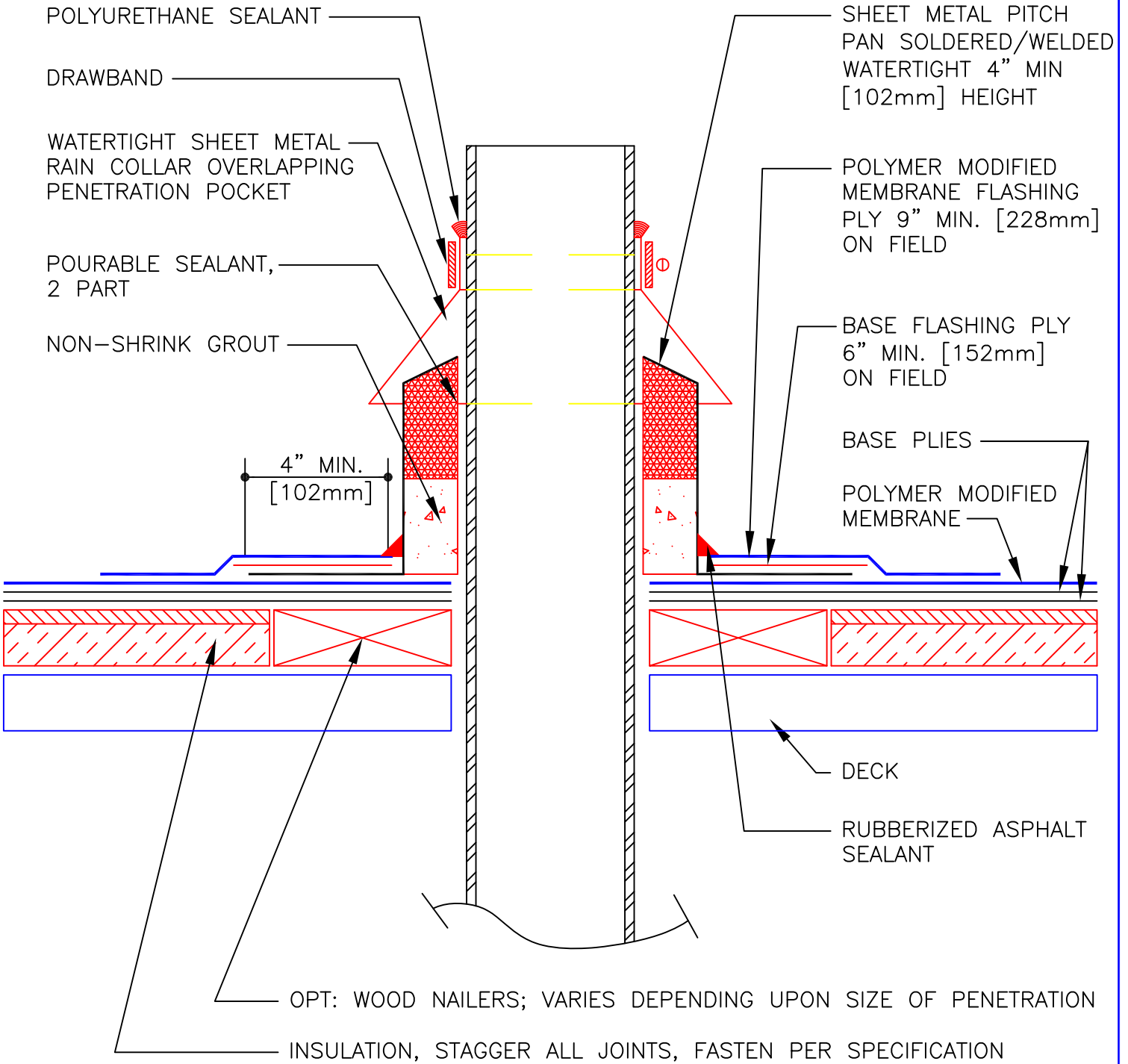

ALL PLIES SET IN MODIFIED COLD ADHESIVE SEE SPECIFICATIONS FOR SURFACING



THE GARLAND COMPANY, INC.
GARLAND CANADA, INC.
THE GARLAND COMPANY UK, LTD

DETAIL:

PITCH POCKET W/UMBRELLA

COLD APPLIED

ZONE 1 INSULATION BOARD FASTENER PATTERN: 11 FASTENERS PER BOARD

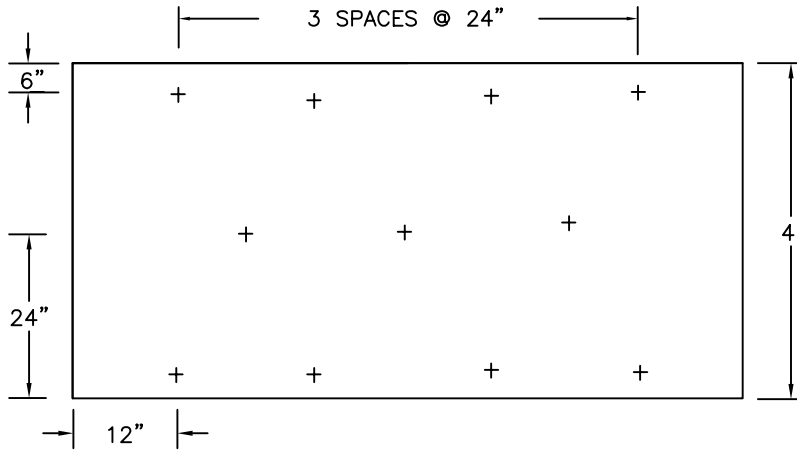

ZONE 2 INSULATION BOARD FASTENER PATTERN: 17 FASTENERS PER BOARD

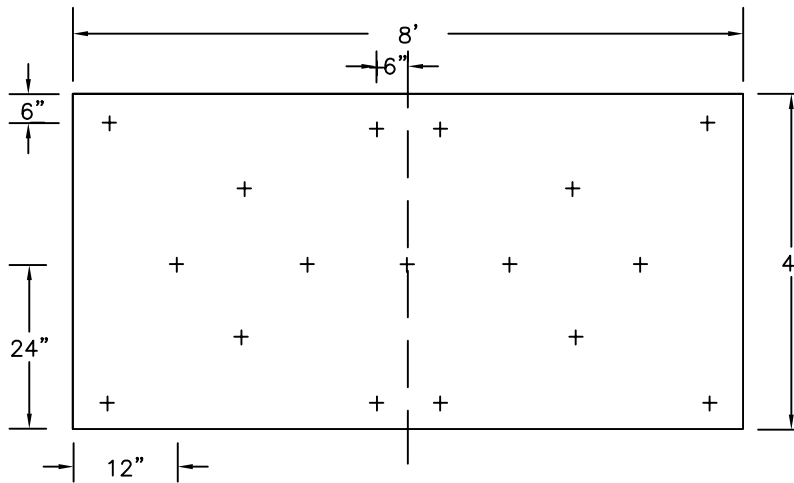

ZONE 3 INSULATION BOARD FASTENER PATTERN: 22 FASTENERS PER BOARD

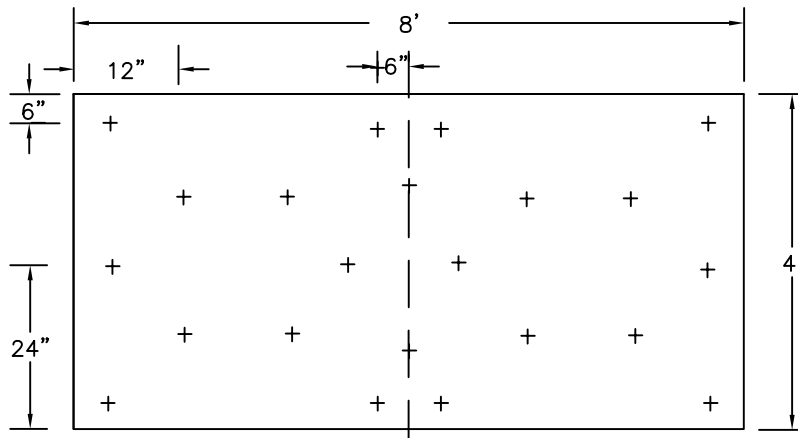

THE GARLAND COMPANY, INC.

3800 EAST 91st STREET
 CLEVELAND, OHIO 44105-2197
 -PHONE 1-800-321-9336-
 FAX 1-216-641-0633

DETAIL:

4 X 8 BOARD PATTERN

SECTION:

INSULATION BOARD FASTENER PATTERN

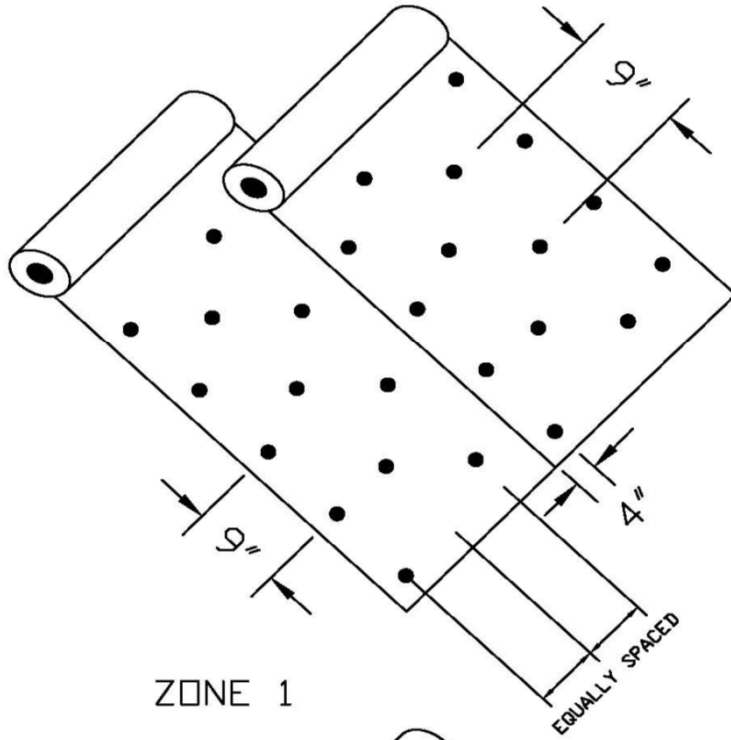

ZONE 1

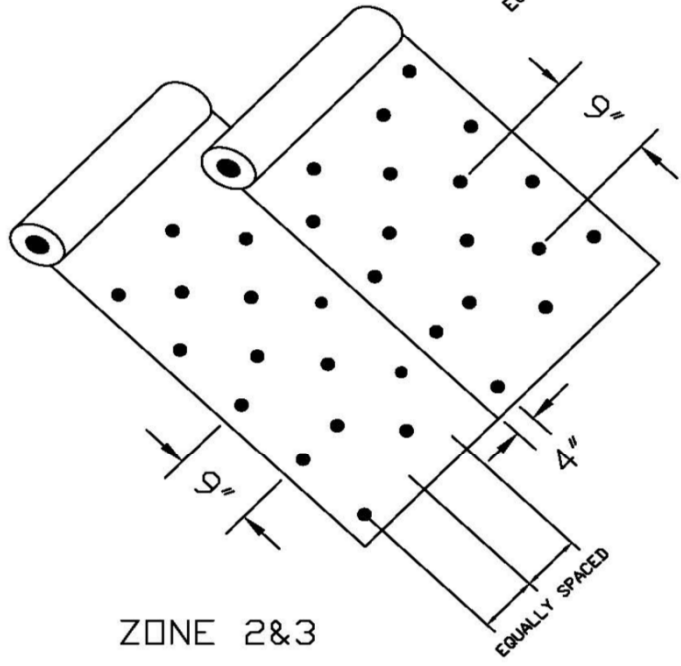

ZONE 2&3



THE GARLAND COMPANY, INC.
 3800 EAST 91st STREET
 CLEVELAND, OHIO 44105-2197
 -PHONE 1-800-321-9336-
 FAX 1-216-641-0633

DETAIL:

ROOF ZONES 1, 2, AND 3

SECTION:

BASE SHEET FASTENER PATTERN

TYPICAL ZONE 1, 2 AND 3 INSULATION BOARD ADHESIVE PATTERN: 12" OC BEADS PER BOARD

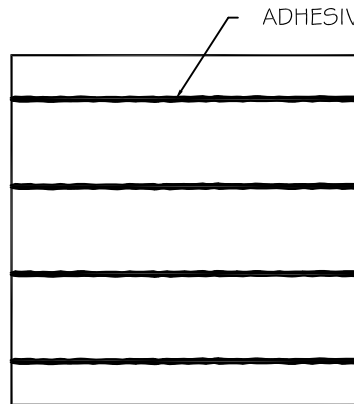

ADHESIVE RIBBON ENLARGED FOR CLARITY

4 ADHESIVE RIBBONS
EQUALLY SPACED AT
12" (30.5cm) O.C. (TYP.)



since 1895

THE GARLAND COMPANY, INC.
GARLAND CANADA, INC.
THE GARLAND COMPANY UK, LTD

DETAIL:

4 X 4 BOARD PATTERN

SECTION:

INSULATION BOARD ADHESIVE PATTERN

Nordonia Hills City School District
9374 Olde Eight Rd.
Northfield, OH 44067
Attn: Mr. Casey Wright
Director of Business

Bid Date 3/17/23 at 11:00 AM

NAME OF BIDDER _____

The undersigned, having examined the specifications and having visited the site and having observed conditions at the site, hereby propose to furnish for the subject projects all labor, material, transportation, equipment and insurances as required for the sums stated below:

Nordonia Elementary School

Base Bid Tear off and Replace Sections A, B, & I per the documents.

Replace Roof **Sections A, B, & I – Hot Applied** per detailed specifications and scope of work.

Labor & Materials not State Term Schedule \$ _____

Materials on Ohio State Term Schedule* \$ _____

Total Labor and All Materials Listed Above \$ _____

Replace Roof **Sections A, B, & I – Cold Applied** per detailed specifications and scope of work.

Labor & Materials not State Term Schedule \$ _____

Materials on Ohio State Term Schedule* \$ _____

Total Labor and All Materials Listed Above \$ _____

Rushwood Elementary School

Base Bid Tear off and Replace Sections D (Area Identified), E, E1, & 4 per the documents.

Replace Roof **Sections D (Area Identified), E, E1, & 4 – Hot Applied** per detailed specifications and scope of work.

Labor & Materials not State Term Schedule \$ _____

Materials on Ohio State Term Schedule* \$ _____

Total Labor and All Materials Listed Above \$ _____

Replace Roof **Sections D (Area Identified), E, E1, & 4 – Cold Applied** per detailed specifications and scope of work.

Labor & Materials not State Term Schedule \$ _____

Materials on Ohio State Term Schedule* \$ _____

Total Labor and All Materials Listed Above \$ _____

Nordonia Middle School

Base Bid Tear off and Replace Sections A, B, & I per the documents.

Replace Roof **Sections J & K – Hot Applied** per detailed specifications and scope of work.

Labor & Materials not State Term Schedule \$ _____

Materials on Ohio State Term Schedule* \$ _____

Total Labor and All Materials Listed Above \$ _____

Replace Roof **Sections J & K – Cold Applied** per detailed specifications and scope of work.

Labor & Materials not State Term Schedule \$ _____

Materials on Ohio State Term Schedule* \$ _____

Total Labor and All Materials Listed Above \$ _____

Unit Costs

1.) Unit cost per square foot to repair deteriorated Metal decking "if found" with approved rust inhibitor upon owner's approval.

Unit cost \$ _____ Per square foot.

2.) Unit cost per square foot to repair Replace Metal decking "if found" with like type and kind, where necessary, upon owner's approval.

Unit cost \$ _____ Per square foot.

3.) Unit cost per square foot to replace Tectum decking "if found" with like type and kind, where necessary, upon owner's approval.

Unit cost \$ _____ Per square foot.

4.) Unit cost per square foot to repair/replace deteriorated/missing wood nailer "if found" with like type and kind, where and as necessary, upon owner's approval.

Unit cost \$ _____ Per lineal foot.

5.) Unit cost to install a drain insert where necessary, upon owner's approval.

Unit cost \$ _____ Per drain.

6.) Unit cost per square foot to install a new drain assembly (plumbing not included) where necessary, upon owner's approval.

Unit cost \$ _____ Per drain.

ACKNOWLEDGEMENT

Bidder hereby acknowledges receipt of Addendum (Addenda)/Clarification Items numbers

LIST ALL NUMBERS RECEIVED: _____

DATE OF COMPLETION

Bidder hereby agrees to commence work upon written notice of Award and to fully complete the projects on or before **August 18, 2023**. **Subject to change based upon material delays. Material delays must be documented and justifiable.**

NAME OF JOB FOREMAN: _____

The foreman named above shall supervise work from start to finish and be on the job each day and hour work is in progress. Each foreman will have a complete set of the **PROJECT MANUAL** and **DRAWINGS** on site at all times

PAY REQUEST AFFIDAVIT:

Be advised that the Bidder awarded the contract will be required to submit a Notarized Affidavit with every pay request application which states that all subcontractors, material suppliers, and any other financial claims against the project have been paid or designate amounts owed. A waiver will be required from the roofing material manufacturer indicating they have been paid.

NOTES:

Nordonia Hills City Schools will exercise their right to purchase Garland roofing materials through the **Ohio Department of Administrative Services State Term Schedule. The successful bidder will be required to provide a detailed material list and quantities for the products to be purchased through the program, and is responsible for all measurements and quantities. Any and all overages are the final responsibility of the contractor*

Failure to **SIGN BELOW** may result in the rejection of the bid

Date _____

By _____

Title _____

Firm Name _____

Address _____

City _____ State _____ Zip code _____

Phone # _____

Fax # _____

Email _____