

BOARD OF EDUCATION
MADRID-WADDINGTON CENTRAL SCHOOL
Monday, April 20, 2026
High School Library
6:00 PM

- I. Call to Order
- II. Pledge of Allegiance
- III. Acceptance of Minutes from March 17, 2026 regular Board meeting
- IV. Reports
 1. Treasurer's Reports
 - Action Item: Acceptance of Reports
 2. CSE & CPSE Recommendations
 - Action Item: Acceptance of CSE & CPSE Recommendations
 3. Student Liaison Representative
 4. High School
 - Key Club
 - MCI Drill: Mock DWI
 - End of Year Events
 5. Elementary
 - Reading Curriculum Update
 - Upcoming Events
- V. Public Comment (3 minute limit per person)
- VI. Superintendent's Report
 1. Capital Project Update
 2. Public Vote Resolution Preview
 3. 2026-2027 Property Tax Report Card
 - Action Item: Approval of Property Tax Report Card
 4. 2026-2027 Sports Mergers
 - Action Item: Approval of 2026-2027 Sports Mergers
- VII. Discussion of Old or New Business
 1. BOCES 2026-2027 Budget & Board Member Vote
 - Action Item: Approval of BOCES 2026-2027 Administrative Budget
 - Action Item: Approval of BOCES Board Members
 2. School Physician Contract
 3. Sale of Kitchen Kettle
 4. North Coast Therapy 2026-2027 Contracts
 - Action Item: Approval of 2026-2027 Contracts
- VIII. Personnel
 - Action Item: Approval of Personnel Recommendations
- IX. Executive Session

(If necessary, "for the purpose of discussion related to the matters leading to the appointment, employment, promotion, demotion, discipline, suspension, dismissal or removal of a particular person or corporation.")
- X. Adjournment

Upcoming Dates:

May 12 Public Budget Hearing 5 PM

May 19 Budget & BOE Member Vote; Regular Meeting 6:00 PM

A Regular Meeting of the Board of Education of the Madrid-Waddington Central School was held on March 17, 2026. The President of the Board, Bob Smith, called the meeting to order at 6:00 PM.

ROLL CALL Present: Bruce Durant, Brian Hammond, Ryan Hayes, Amber LeFleur, Chris Pryce and Bob Smith

Others: Eric Burke, Julie Abrantes, Joseph Binion, Nicole Miller, Patricia Bogart, Larry Legault, Ted Schulz (out at 6:04 PM), Mady VanGorden, Alivia Burns, Mackinley Wells (out at 6:04 PM), Kayden Dyer (out at 6:04 PM), Keianna Webb, Ravyn Ordway, Brycen Hitsman, Samantha Milburn, Natalie McKnight, Austin Sullivan, Tyree Hawkins and Reese Durannt

Excused: Wyatt Boswell, Charles Grant and Katie Logan

NO. 2026-084 Motion by Durant, seconded by Hammond, to approve the minutes of the February 10, 2026 regular board of education meeting.
Approval of Minutes

Yeas: All Present

Nays: None

Drone Soccer National's Overnight Trip – Tyree Hawkins, Samantha Milburn, Mackinley Wells and Kayden Dyer

NO. 2026-085 Motion by Pryce, seconded by LeFleur, that the board, upon the recommendation of Superintendent Burke, does hereby approve the overnight trip for the Drone Soccer National Competition in Orlando, FL from May 17 – May 20, 2026.
Trip - Drone Nat'l Comp.

Yeas: All Present

Nays: None

NO. 2026-086 Motion by Pryce, seconded by Hayes, to accept the Treasurer's Report for the period ending February 28, 2026.
Treasurer's Report

Yeas: All Present

Nays: None

NO. 2026-087 Motion by Durant, seconded by Pryce, that the Board, upon the recommendation of Superintendent Burke, does hereby accept the recommendation of the CSE and CPSE Committees on Special Education, as listed on the attached sheets, and approves of the authorization of funds to implement the special education programs and services consistent with such recommendations.
CSE/CPSE

Yeas: All Present

Nays: None

The Following Reports Were Given:

- Transportation – written by Shawn Losey
- Custodial – written by Jim Murray

- Capital Outlay

NO. 2026-088 Motion by Hammond, seconded by Durant, that the board, upon the recommendation of Superintendent
SEQRA Burke does hereby resolve the following:

2026-2027
Cap Outlay
Project

WHEREAS, the Board of Education of the Madrid-Waddington Central School District will be considering a proposition to undertake the 2026-2027 Capital Outlay Project consisting of window replacement; and

WHEREAS, the proposed elements of the 2026-2027 Capital Outlay Project are routine activities of an educational institution for the purpose of maintenance or repair of existing structures and facilities; replacement, rehabilitation or reconstruction of a structure or facility, in kind; and/or routine activities of educational institutions including expansion of existing facilities by less than 10,000 feet of gross floor area; and

WHEREAS, such actions are deemed, pursuant to the regulations adopted by the New York State Department of Environmental Conservation, to be "Type II" actions and are not subject to the requirements of the New York State Environmental Quality Review Act;

NOW THEREFORE IT IS RESOLVED, that the proposed proposition is a Type II action pursuant to 6 NYCRR § 617.5(c) and that review pursuant to the New York State Environmental Quality Review Act is not necessary.

Yeas: All Present

Nays: None

Reports Cont'd:

- Superintendent's Report – Eric Burke
 - 2026-2027 Budget Update
 - BOCES Expenditures

NO. 2026-089 Motion by Hayes, seconded by Pryce, that the board, upon the recommendation of Superintendent
BOCES Burke, does hereby approve the 2026-2027 BOCES Commitment Form as presented.

2026-2027

Yeas: All Present

Nays: None

Reports Cont'd:

- Superintendent's Report – Eric Burke
 - 2026-2027 Budget Update
 - Review and Consideration of the Proposed 2026-2027 budget expenditures of \$23,577,895 representing a spending increase of 9.66% and a tax increase of 3.25%
 - Revenue Review

NO. 2026-090 Motion by Hammond, seconded by Durant, that the board upon the recommendation of Superintendent
2026-27 Burke does hereby approve the 2026-2027 budget expenditures of \$23,577,895 representing a
Budget spending increase of 9.66%.
Proposal

Yeas: All Present

Nays: None

Discussion of Old and New Business:

- Approval of Surplus Items Designated for Sale

NO. 2026-092 Motion by LeFleur, seconded by Pryce, that the board, upon the recommendation of Superintendent
Nexamp Burke, does hereby approve the letter to Nexamp regarding the Battery Energy Storage System
PILOT letter Project at 658 CTY RT 31, Madrid, NY 13660.

Yeas: All Present

Nays: None

Discussion of Old and New

- SLL BOCES BOE Nomination

NO. 2026-093 Motion by Hammond, seconded by Hayes, that the board, upon the recommendation of Superintendent
BOCES Burke, does hereby nominate Michael Miller of Waddington to the StLL BOCES board.
Nomination
M Miller

Yeas: All Present

Nays: None

NO. 2026-094 Motion by Pryce, seconded by Durant, that the board, upon the recommendation of Superintendent
Lead Water Burke, does hereby resolve the following:
Testing

WHEREAS,

The Cooperative Purchasing Service is a plan of a number of public school districts in the Oswego County Board of Cooperative Educational Services Area in New York (known as the Center for Instruction, Technology & Innovation [CiTi]), to bid jointly for water testing and sampling services, and

WHEREAS,

Madrid-Waddington Central School District (hereinafter the "Participant") is desirous of participating with Oswego County Board of Cooperative Educational Services/CiTi and other Boards of Cooperative Educational Services and public-school districts in the joint bidding of the services mentioned above as authorized by General Municipal Law, Section 119-o, and

WHEREAS,

The participant wishes to appoint the Oswego County Board of Cooperative Educational Services/CiTi to advertise for bids, accept bids, tabulate bids and award bids on their behalf; therefore

BE IT RESOLVED,

The participant hereby appoints Oswego County Board of Cooperative Educational Services/CiTi to represent it in all matters relating above, and designates the Oswego County Board of Cooperative Educational Services/CiTi designated newspaper(s) as the legal publication(s) for all Cooperative Purchasing bid notifications, and,

BE IT FURTHER RESOLVED,

The participant authorizes the Oswego County Board of Cooperative Educational Services/CiTi to represent it in all matters leading up to the entering into a contract for the purchase of the above-mentioned services, and,

BE IT FURTHER RESOLVED,

The participant agrees to (1) assume its equitable share of the costs of the Cooperative Bidding; (2) abide by majority decisions of the participating districts; (3) abide by the Award of the Oswego County Board of Cooperative Educational Services/CiTi; (4) and that after the award of the bid it will conduct all negotiations directly with the successful bidder(s)

WHEREAS, the Board of Education believe that such agreement is in the best financial interest of the District because it is the cost-effective means for instructional copying, scanning and printing; and

WHEREAS, the Board of Education has determined that such agreement is an ordinary contingent expense.

NOW, THEREFORE, BE IT RESOLVED that the Board of Education of the Madrid-Waddington Central School District approves the lease of 3 photocopier/scanner/printer machines at a cost of \$59,580 with St. Lawrence-Lewis BOCES and authorizes the Superintendent to sign the contract. Further, the Board of Education authorizes any additional financing and/or BOCES administrative costs.

Yeas: All Present

Nays: None

NO. 2026-096 Motion by Pryce, seconded by Durant, that the board, upon the recommendation of Superintendent Burke, does hereby approve the following 2025-26 personnel actions:

Appointments:

- | | |
|-----------------|---------------------------------------------------------------------------------|
| Election Clerks | 1. Election Clerks; as per attached listing, May 19, 2026, vol. |
| K Kowalchuk | 2. Kristina Kowalchuk; LTS Elem Tch., eff. 4/1/26-6/26/26, rate of \$274.97/day |
| K Borneo | 3. Kholeen Borneo; 4-Yr Prob. Spanish Tch., eff. 8/1/26, salary of \$63,559 |
| E Bates | 4. Erika Bates; Vol. Mod Softball Coach, eff. 3/18/26 |
| C Barkley | 5. Carie Ann Barkley; Sub. Tch. & Teach. Asst., eff. 3/5/26, rate of \$135/day |
| C Barkley | 6. Carie Ann Barkley; Sub Monitor, eff. 3/18/26, rate of \$17/hr. |
| E Furlong | 7. Elizabeth Furlong; Sub Keyboard Specialist, eff. 3/18/26, rate of \$19/hr. |
| E Furlong | 8. Elizabeth Furlong; Sub Mon. & FSW, eff. 3/18/26, rate of \$17/hr. |
| T Flanagan | 9. Tod Flanagan; Sub Bus Driver, eff. 3/18/26, rate of \$27/hr. |
| P DiLenno | 10. Philip DiLenno; 5-hr Bus Driver, eff. 4/13/26, rate of \$27.04/hr. |

Resignations:

- | | |
|------------|-----------------------------------------------|
| B Hammond | 11. Brianna Hammond; Elem. Tch., eff. 4/7/26 |
| M VanAcker | 12. Meghan VanAcker; Elem. Tch., eff. 6/30/26 |

Tenure:

- | | |
|------------|------------------------------------------------|
| B Davey | 13. Bridget Davey; Spec. Ed. Tch., eff. 9/1/26 |
| B Hammond | 14. Brianna Hammond; Elem. Tch., eff. 9/1/26 |
| E Bahr | 15. Emily Bahr; Elem. Tch., eff. 9/1/26 |
| B Sabatini | 16. Bonnie Sabatini; Science Tch., eff. 9/1/26 |
| C Averill | 17. Carla Averill; Tch. Asst., eff. 9/1/26 |
| A Young | 18. Angel Young; Tch. Asst., eff. 9/1/26 |

Yeas: Durant, Hayes, LeFleur, Pryce and Smith

Abstains: Hammond

Nays: None

No. 2026-097 Motion by Hammond, seconded by Durant, to adjourn the regular meeting at 6:41 PM.
Adjournment

Yeas: All

Budgetary Transfer Report

Fiscal Year: 2026

Current Appropriation - Effective From: 03/31/2026 To: 03/31/2026

Effective Date	Trans ID	Transaction Description	Budget Account	Description	Amount Transferred From	Amount Transferred To
Fund: A - GENERAL FUND						
03/31/2026	002694	3rd quarter transfers				
		A1010-500-00-0000 R		Board Education Supplies	-19.99	
		A1621-200-00-0000 R		Maintenance Equipment	-850.34	
		A1680-490-00-0000 R		Data Processing BOCES	-800.00	
		A2020-161-05-0000 R		Secretaries' Sal - HS	-1,006.50	
		A2110-120-00-0000 R		Teacher Salaries K-3	-21,000.00	
		A2110-400-00-0000 R		General Other Expense	-4,000.00	
		A2110-400-03-1800 R		K-5 Teacher Conference	-3,000.00	
		A2110-470-00-0000 R		Tuition - K-5	-23,000.00	
		A2110-480-03-0100 R		Textbooks K-5	-4,102.82	
		A2110-500-03-0100 R		General K-5 Supplies	-52.79	
		A2250-160-01-0000 R		Hdkp Noninstr Sal K-5	-3,500.00	
		A2250-470-00-0000 R		Handicapped tuition K-5	-13,057.14	
		A2250-500-00-1000 R		CSE Supplies - UPK	-111.98	
		A2280-150-00-0100 R		Sub Occ Ed Tch Salaries	-100.00	
		A2610-150-00-0000 R		Library InstrSal - K-5	-559.51	
		A2610-150-00-0000 R		Library InstrSal - K-5	-28.60	
		A2850-150-05-0000 R		After School Prog 7-12	-279.80	
		A2850-400-03-0000 R		After School Other - K-5	-1,000.00	
		A2850-500-03-0000 R		After School Sup. K-5	-965.00	
		A1010-400-00-0000 R		Board Education Other		19.99
		A1670-490-00-0000 R		Printing BOCES Services		800.00
		A2020-150-00-0000 R		Principals' Salaries-Elem		431.00
		A2020-161-00-0000 R		Secretaries' Sal - Elem		575.50
		A2110-131-00-0000 R		TCH ASSIST Salaries 7-12		1,000.00
		A2110-140-03-0000 R		Substitute TCH - 7-12		20,000.00
		A2110-150-05-0000 R		Tutoring Salaries- 7-12		2,000.00
		A2110-200-00-0000 R		General Equipment K-12		850.34
		A2110-470-03-1100 R		Tuition - 7-12		30,000.00
		A2110-480-05-0100 R		Textbooks 7-12		729.11
		A2110-500-03-0000 R		General Pre-K Supplies		52.79
		A2250-160-00-0000 R		Hdkp Noninstr Sal Pre-K		1,500.00
		A2250-500-05-0000 R		Handicapped 7-12 Supplies		111.98
		A2280-150-00-0000 R		Occ Ed Teacher Salaries		100.00
		A2610-150-00-0100 R		Sub Lib Instr Sal - K-5		559.51
		A2610-150-05-0100 R		Sub Library Tch Sal 7-12		28.60
		A2630-220-00-0000 R		State Aided Comput Hrdwre		3,373.71
		A2630-400-00-0000 R		Computer Other		12,000.00
		A2630-400-00-1000 R		Comp Prof Dev Other		1,057.14
		A2850-150-03-0200 R		After School Sal. 6		279.80
		A2850-400-00-0000 R		General Co. Other 7-12		1,965.00
03/31/2026	002695	3rd quarter transfers				
		A1621-200-00-0000 R		Maintenance Equipment	-4,506.00	
		A2250-150-03-0100 R		Handicapped TCH SAL 6	-1,500.00	
		A2250-151-03-0100 R		Hdkp Tch Asst 6	-1,500.00	
		A2250-151-05-0000 R		Hdkp Tch Asst 7-12		3,000.00
		A2630-200-01-0000 R		Equipment		4,506.00
03/31/2026	002696	3rd quarter transfers				
		A2110-480-03-0300 R		Textbooks 6	-974.54	
		A2630-220-00-0000 R		State Aided Comput Hrdwre		974.54
		Total for Fund A - GENERAL FUND			-85,915.01	85,915.01

J Abrantes
3/31/26

Madrid-Waddington Central School District
 Interfund Transfer Activity
 For the Period July 1, 2025 - March 31, 2026
 For the Fiscal Year Ending June 30, 2026

Expenditures

General Fund		Amount
9901-930	Transfer To School Lunch	
9901-950	Transfer To Special Funds (F) (Summer School F62026)	
9950-900	Transfer to Capital/Debt Service Bus Purchase with Cap Funds Cap Outlay Proj 2025-26	100,000.00

Debt Service		
9901-900	Transfer to General Fund	300,000.00

400,000.00

Revenues

Federal Funds		
5031-F62025	Summer School F62026	

School Lunch		
5031.000	School Lunch	

General Fund		
5050.000	Interfund Tran for Debt Service	300,000.00

Capital Funds		
5031-H12025	Capital Outlay Proj 2025-26	100,000.00
5031-H22025	Bus	

400,000.00



MADRID-WADDINGTON CSD

A/P Check Register
Bank Account: CBCAPFUND - COMMUNITY BANK CAPITAL FUND

Check Number	Check Date	Pay Type	Remit To	Warrant	Fund	Recorded	Void	Date	Reason	Check Amount	Check Number
002500	03/13/2026	C	A-Verdi Storage Containers	0069		No	No			\$399.00	002500
002501	03/13/2026	C	ATLANTIC TESTING LABORATORIES LTD	0069		No	No			\$660.00	002501
002502	03/13/2026	C	LEGAULTLARRY	0069		No	No			\$2,884.62	002502
002503	03/13/2026	C	NORTHERN TIER CONTRACTING, INC.	0069		No	No			\$196,346.70	002503
002504	03/17/2026	C	SEI DESIGN GROUP ARCHITECTS, PC	0070		No	No			\$6,648.00	002504
002505	03/26/2026	C	A-Verdi Storage Containers	0072		No	No			\$114.00	002505
002506	03/26/2026	C	ATLANTIC TESTING LABORATORIES LTD	0072		No	No			\$1,295.00	002506
002507	03/26/2026	C	LEGAULTLARRY	0072		No	No			\$2,884.62	002507
002508	03/26/2026	C	SEI DESIGN GROUP ARCHITECTS, PC	0072		No	No			\$10,164.00	002508
002509	03/26/2026	C	TJ FIACCO CONSTRUCTION, LLC	0072		No	No			\$116,018.25	002509
Subtotal for Bank Account: CBCAPFUND - COMMUNITY BANK CAPITAL FUND										Grand Total	\$337,414.19
										Void Total	\$0.00
										Net	\$337,414.19
										Grand Total	\$337,414.19
										Void Total	\$0.00
										Net	\$337,414.19

Selection Criteria

Bank Account: CBCAPFUND
Check date is between 03/01/2026 and 03/31/2026
Sort by: Check Number
Printed by JULIE K. ABRANTES

MADRID-WADDINGTON CSD
A/P Check Register
Bank Account: CBGENFUND - COMMUNITY BANK GENERAL FUND

Check Number	Check Date	Pay Type	Remit To	Warrant Fund	Recorded	Void	Date	Reason	Check Amount	Check Number
098946	08/14/2025	C	LJC DISTRIBUTORS	0012	No	Yes	3/5/2026	Cash Replacement Check # 098943 Issued	(\$175.00)	098946
098943	03/05/2026	C	LJC DISTRIBUTORS	0067	No	No			\$175.00	098943
098944	03/05/2026	C	ALLTECH INTEGRATIONS, INC.	0067	No	No			\$4,361.95	098944
098945	03/05/2026	C	AMAZON.COM	0067	No	No			\$1,501.60	098945
098946	03/05/2026	C	AUTO ZONE STORE 02984	0067	No	No			\$517.97	098946
098947	03/05/2026	C	BELLEWALKER	0067	No	No			\$135.50	098947
098948	03/05/2026	C	CAUFIELD WATTHEW	0067	No	No			\$463.50	098948
098949	03/05/2026	C	COAKLEYBRIAN	0067	No	No			\$104.50	098949
098950	03/05/2026	C	FROATSBIRGAIL	0067	No	No			\$20.00	098950
098951	03/05/2026	C	GILLEE'S AUTO TRUCK & MARINE	0067	No	No			\$789.70	098951
098952	03/05/2026	C	GRAINGER	0067	No	No			\$370.84	098952
098953	03/05/2026	C	JOHNSON NEWSPAPER CORP	0067	No	No			\$421.32	098953
098954	03/05/2026	C	JOHNSTONRAE	0067	No	No			\$142.00	098954
098955	03/05/2026	C	LaQuierHenry	0067	No	No			\$113.50	098955
098956	03/05/2026	C	LAVALLEYTIMMY	0067	No	No			\$732.40	098956
098957	03/05/2026	C	LYONMARK	0067	No	No			\$188.50	098957
098958	03/05/2026	C	MARQUARTSTUART	0067	No	No			\$256.50	098958
098959	03/05/2026	C	MF ATHLETIC	0067	No	No			\$151.00	098959
098960	03/05/2026	C	MX FUELS	0067	No	No			\$21,029.62	098960
098961	03/05/2026	C	MYERSJAMES	0067	No	No			\$128.50	098961
098962	03/05/2026	C	NY BUS SALES	0067	No	No			\$497.48	098962
098963	03/05/2026	C	PAYNEWILLIAM	0067	No	No			\$139.50	098963
098964	03/05/2026	C	PTNEY BOWES INC	0067	No	No			\$5,663.05	098964
098965	03/05/2026	C	PRASHAWCRAIG	0067	No	No			\$139.50	098965
098966	03/05/2026	C	REIDERNIE	0067	No	No			\$161.50	098966
098967	03/05/2026	C	RockthruJoe	0067	No	No			\$139.50	098967
098968	03/05/2026	C	SLIC FIBER	0067	No	No			\$208.25	098968
098969	03/05/2026	C	W.B. MASON CO. INC.	0067	No	No			\$178.20	098969
098970	03/05/2026	C	WADDINGTON HARDWARE BUILDING SUPPLY	0067	No	No			\$89.11	098970
098971	03/10/2026	C	MMCS PAYROLL ACCOUNT	0068	No	No			\$334,085.31	098971
098972	03/13/2026	C	ADVANCE MAGAZINE PUBLISHERS INC	0068	No	No			\$524.56	098972
098973	03/13/2026	C	AMAZON.COM	0068	No	No			\$172.80	098973
098974	03/13/2026	C	BLICK ART MATERIALS	0068	No	No			\$46.32	098974
098975	03/13/2026	C	BURKE WICHELLE	0068	No	No			\$355.39	098975
098976	03/13/2026	C	CLAYTON-HEBURN MEDICAL CENTER	0068	No	No			\$3,000.00	098976
098977	03/13/2026	C	CONVERSE LABORATORIES, INC	0068	No	No			\$32.00	098977
098978	03/13/2026	C	DEMCO	0068	No	No			\$102.95	098978

Payment Types: C=Computer Check A=Automated Payment E=Electronic Transfer(Manual) M=Manual Check

MADRID-WASHINGTON CSD

A/P Check Register
Bank Account: CBGENFUND - COMMUNITY BANK GENERAL FUND

Check Number	Check Date	Pay Type	Remit To	Warrant	Fund	Recorded	Void	Date	Reason	Check Amount	Check Number
096879	03/13/2026	C	FRANKLIN/ESSEX/HAMILTN BOCES	0069		No	No			\$50.00	096879
096880	03/13/2026	C	G & E EXTINGUISHERS	0069		No	No			\$1,317.00	096880
096881	03/13/2026	C	HOME DEPOT	0069		No	No			\$446.49	096881
096882	03/13/2026	C	JOHNSTONS WATER, LLC	0069		No	No			\$30.35	096882
096883	03/13/2026	C	LIBERTY UTILITIES - NY	0069		No	No			\$519.47	096883
096884	03/13/2026	C	LITERACY RESOURCES, LLC	0069		No	No			\$199.36	096884
096885	03/13/2026	C	LJC DISTRIBUTORS	0069		No	No			\$315.00	096885
096886	03/13/2026	C	LOWE'S WAREHOUSE	0069		No	No			\$453.85	096886
096887	03/13/2026	C	NATIONAL GRID	0069		No	No			\$527.32	096887
096888	03/13/2026	C	NORTH COUNTRY THIS WEEK	0069		No	No			\$541.95	096888
096889	03/13/2026	C	NORWOOD-NORFOLK CENTRAL SCHOOL	0069		No	No			\$13,354.85	096889
096890	03/13/2026	C	NYS DEPT OF ENVIRONMENTAL CONSERVATION	0069		No	No			\$330.00	096890
096891	03/13/2026	C	POTSDAM CENTRAL SCHOOL	0069		No	No			\$16,160.40	096891
096892	03/13/2026	C	SPRAGUE ENERGY SOLUTIONS, INC.	0069		No	No			\$2,765.64	096892
096893	03/13/2026	C	SWINYERIEYON M.	0069		No	No			\$125.00	096893
096894	03/13/2026	C	ULINE	0069		No	No			\$1,314.89	096894
096895	03/13/2026	C	VITAL RECORDS CONTROL	0069		No	No			\$27.91	096895
096896	03/13/2026	C	WASHINGTON HARDWARE BUILDING SUPPLY	0069		No	No			\$34.36	096896
096897	03/17/2026	C	BURKEVERIC S	0070		No	No			\$793.80	096897
096898	03/17/2026	C	CAFARELLAVANITA	0070		No	No			\$104.07	096898
096899	03/17/2026	C	CANTON CENTRAL SCHOOL	0070		No	No			\$6,000.00	096899
096900	03/17/2026	C	COLDTECH COMMERCIAL SERVICES, INC	0070		No	No			\$991.07	096900
096901	03/17/2026	C	EXCELLUS HEALTH PLAN - GROUP	0070		No	No			\$183,339.20	096901
096902	03/17/2026	C	GROSSMORGAN	0070		No	No			\$270.00	096902
096903	03/17/2026	C	NATIONAL GRID	0070		No	No			\$5,101.07	096903
096904	03/17/2026	C	NORTH COAST THERAPY	0070		No	No			\$5,407.20	096904
096905	03/17/2026	C	ST LAWRENCE-LEWIS BOCES	0070		No	No			\$376,292.58	096905
096906	03/17/2026	C	WASHINGTON HARDWARE BUILDING SUPPLY	0070		No	No			\$29.97	096906
096907	03/24/2026	C	MNCS PAYROLL ACCOUNT	0071		No	No			\$347,031.72	096907
096908	03/26/2026	C	AETNA	0072		No	No			\$55,386.90	096908
096909	03/26/2026	C	AJ'S PORTABLES, LLC	0072		No	No			\$1,200.00	096909
096910	03/26/2026	C	AMAZON.COM	0072		No	No			\$93.64	096910
096911	03/26/2026	C	AUTO ZONE STORE 02984	0072		No	No			\$720.49	096911
096912	03/26/2026	C	BOND SCHOENECK & KING, PLLC	0072		No	No			\$63.75	096912
096913	03/26/2026	C	BURKE MICHELLE	0072		No	No			\$89.95	096913
096914	03/26/2026	C	Chase Cardmember Service	0072		No	No			\$2,269.76	096914
096915	03/26/2026	C	DAVIS VISION, INC	0072		No	No			\$1,377.26	096915

Payment Types: C=Computer Check A=Automated Payment E=Electronic Transfer(Manual) M=Manual Check

MADRID-WADDINGTON CSD

A/P Check Register

Bank Account: CBGENFUND - COMMUNITY BANK GENERAL FUND

Check Number	Check Date	Pay Type	Remit To	Warrant	Fund	Recorded	Void	Date	Reason	Check Amount	Check Number
096916	03/26/2026	C	GUARDIAN	0072		No	No			\$4,022.28	096916
096917	03/26/2026	C	LIBERTY UTILITIES - NY	0072		No	No			\$5,805.03	096917
096918	03/26/2026	C	LIFETIME BENFITS SOLUTIONS, INC	0072		No	No			\$293.00	096918
096919	03/26/2026	C	MX FUELS	0072		No	No			\$1,890.44	096919
096920	03/26/2026	C	NNYWWC	0072		No	No			\$60.00	096920
096921	03/26/2026	C	PITNEY BOWES GLOBAL FINANCIAL SERVICES,	0072		No	No			\$251.22	096921
096922	03/26/2026	C	SMEC	0072		No	No			\$18,577.31	096922
096923	03/26/2026	C	ST LAWRENCE SUPPLY COMPANY	0072		No	No			\$476.84	096923
096924	03/26/2026	C	TEACHERS PAY TEACHERS	0072		No	No			\$69.13	096924
096925	03/26/2026	C	VERIZON WIRELESS	0072		No	No			\$1,661.54	096925
096926	03/26/2026	C	VICTORY PROMOTIONS, INC.	0072		No	No			\$359.75	096926
096927	03/26/2026	C	W.B. MASON CO, INC.	0072		No	No			\$7,956.04	096927
096928	03/26/2026	C	WHITESBORO PLOW SHOP INC	0072		No	No			\$390.00	096928

Subtotal for Bank Account: CBGENFUND - COMMUNITY BANK GENERAL FUND

Grand Total \$1,444,081.15
Void Total (\$175.00)
Net \$1,443,886.15

Grand Total \$1,444,081.15
Void Total (\$175.00)
Net \$1,443,886.15

Selection Criteria

Bank Account: CBGENFUND
Check date is between 03/01/2026 and 03/31/2026
Sort by: Check Number
Printed by JULIE K. ABRANTES

MADRID-WADDINGTON CSD
Budget Status Report As Of: 03/31/2026
Fiscal Year: 2026

Fund: A GENERAL FUND

Budget Account	Description	Initial Appropriation	Adjustments	Current Appropriation	Year-to-Date Expenditures	Encumbrance Outstanding	Unencumbered Balance
1010-400-00-0000	Board Education Other	7,500.00	19.99	7,519.99	7,519.99	0.00	0.00
1010-400-00-1000	Prof Dev Other	5,500.00	0.00	5,500.00	0.00	0.00	5,500.00
1010-490-00-0000	BOCES Services	9,400.00	0.00	9,400.00	3,290.00	0.00	6,110.00
1010-500-00-0000	Board Education Supplies	750.00	-19.99	730.01	38.49	0.00	693.52
1040-160-00-0000	District Clerk Salary	109,251.00	1,575.40	110,826.40	85,251.00	25,575.40	0.00
1040-400-00-0000	District Clerk Other	1,000.00	-500.00	500.00	42.00	0.00	458.00
1040-400-00-1000	Prof Dev Other	750.00	-500.00	250.00	0.00	0.00	250.00
1040-500-00-0000	District Clerk Supplies	750.00	-575.40	174.60	153.94	0.00	20.66
1060-400-00-0000	District meetings other	3,500.00	0.00	3,500.00	0.00	2,938.48	561.52
10 Board of Education - State Function Group Subtotal		138,401.00	0.00	138,401.00	98,293.42	28,513.88	13,593.70
1240-150-00-0000	Superintendent Salary	110,580.00	0.00	110,580.00	82,198.80	24,669.87	3,713.33
1240-160-00-0000	Superintendent Secretary	58,368.00	0.00	58,368.00	44,768.20	13,429.80	172.00
1240-400-00-0000	Chief School Admin Other	7,915.00	0.00	7,915.00	3,692.43	0.00	4,222.57
1240-400-00-1000	Prof Dev Other	7,500.00	0.00	7,500.00	5,726.34	0.00	1,773.66
1240-500-00-0000	Chief School Admin Suppli	1,000.00	0.00	1,000.00	112.78	0.00	887.22
12 Central Administration - State Function Group Subtotal		185,363.00	0.00	185,363.00	136,494.55	38,099.67	10,768.78
1310-150-00-0000	Business Admin Instructio	54,485.00	0.00	54,485.00	41,110.80	12,322.53	1,031.67
1310-160-00-0000	Business Admin NonInstruc	27,555.00	4,398.90	31,951.90	24,578.60	7,373.30	0.00
1310-400-00-0000	Business Admin Other	34,233.00	-5,208.90	29,024.10	15,428.10	167.97	13,430.03
1310-400-00-1000	Prof Dev Other	1,000.00	0.00	1,000.00	0.00	0.00	1,000.00
1310-490-00-0000	BOCES Services	38,516.00	0.00	38,516.00	17,716.69	0.00	20,799.31
1310-500-00-0000	Business Admin Supplies	4,250.00	0.00	4,250.00	2,289.25	31.69	1,929.06
1320-400-00-0000	Auditing Other Exp	32,500.00	0.00	32,500.00	28,800.00	0.00	3,700.00
1325-160-00-0000	Treasurer Salary	21,550.00	238.60	21,788.60	16,760.40	5,028.20	0.00
1325-400-00-0000	Treasurer Other	525.00	-238.60	286.40	0.00	0.00	286.40
1325-400-00-1000	Prof Dev Other	250.00	0.00	250.00	0.00	0.00	250.00
1325-500-00-0000	Treasurer Supplies	100.00	0.00	100.00	0.00	0.00	100.00
1330-160-00-0000	Tax Collector Salary	4,888.00	812.00	5,700.00	5,700.00	0.00	0.00
1330-400-00-0000	Tax Collector Other	485.00	52.54	517.54	517.54	0.00	0.00
1330-500-00-0000	Tax Collector Supplies	600.00	-52.54	547.46	296.65	0.00	250.81
1345-490-00-0000	Purchase BOCES Services	2,548.00	0.00	2,548.00	1,782.90	0.00	765.10
1380-400-00-0000	Fiscal Agent Fees	7,500.00	0.00	7,500.00	0.00	0.00	7,500.00
13 Finance - State Function Group Subtotal		230,945.00	0.00	230,945.00	154,978.93	24,923.69	51,042.38
1420-400-00-0000	Legal Other Expense	15,000.00	0.00	15,000.00	2,698.25	0.00	12,303.75
1430-490-00-0000	BOCES Services - PERS	23,545.00	0.00	23,545.00	16,481.50	0.00	7,063.50
1480-490-00-0000	BOCES Services	2,500.00	0.00	2,500.00	0.00	0.00	2,500.00
14 Staff - State Function Group Subtotal		41,045.00	0.00	41,045.00	19,177.75	0.00	21,867.25
1620-160-00-0000	Operation Salaries	308,045.00	0.00	308,045.00	212,212.51	64,147.84	31,684.65

MADRID-WADDINGTON CSD

Budget Status Report As Of: 03/31/2026

Fiscal Year: 2026

Fund: A GENERAL FUND

Budget Account	Description	Initial Appropriation	Adjustments	Current Appropriation	Year-to-Date Expenditures	Encumbrance Outstanding	Unencumbered Balance
1620-200-00-0000	Operation Equipment	5,000.00	0.00	5,000.00	0.00	0.00	5,000.00
1620-400-00-0000	Operation Other Expense	15,000.00	0.00	15,000.00	1,189.00	0.00	13,811.00
1620-400-00-1000	Prof Dev Other	1,000.00	0.00	1,000.00	60.00	0.00	940.00
1620-402-00-0000	Natural Gas	110,000.00	0.00	110,000.00	45,275.55	0.00	64,724.45
1620-407-00-0000	Electricity	150,000.00	0.00	150,000.00	133,077.98	0.00	16,922.02
1620-408-00-0000	Telephone	15,680.00	0.00	15,680.00	7,966.29	0.00	7,713.71
1620-480-00-0000	BOCES Services	22,668.00	0.00	22,668.00	16,097.20	0.00	6,570.80
1620-500-00-0000	Operation Supplies	70,000.00	0.00	70,000.00	49,554.47	2,436.19	18,009.34
1620-500-01-0000	Auditorium Supplies	1,000.00	0.00	1,000.00	0.00	0.00	1,000.00
1621-160-00-0000	Maintenance Salaries	387,675.00	0.00	387,675.00	247,515.11	64,148.01	76,011.88
1621-160-02-0000	Maint Salaries - Chem Hyg	1,750.00	0.00	1,750.00	345.97	1,000.00	404.03
1621-200-00-0000	Maintenance Equipment	23,000.00	-5,356.34	17,643.66	10,150.00	0.00	7,493.66
1621-200-01-0000	Auditorium Equipment	5,000.00	0.00	5,000.00	0.00	0.00	5,000.00
1621-200-02-0000	Equip - Security	25,000.00	0.00	25,000.00	0.00	0.00	25,000.00
1621-400-00-0000	Maintenance Other	85,000.00	0.00	85,000.00	24,203.46	1,100.00	59,696.54
1621-400-01-0000	Auditorium Other	2,500.00	0.00	2,500.00	0.00	0.00	2,500.00
1621-480-00-0000	Maintenance - BOCES Svces	19,780.00	0.00	19,780.00	13,846.00	0.00	5,934.00
1621-500-00-0000	Maintenance Supplies	55,000.00	0.00	55,000.00	20,757.99	495.00	33,747.01
1670-400-00-0000	Mailing Other Expense	7,710.00	0.00	7,710.00	6,869.08	0.00	840.92
1670-480-00-0000	Printing BOCES Services	2,000.00	800.00	2,800.00	2,800.00	0.00	0.00
1670-500-00-0000	Mailing Supplies	500.00	0.00	500.00	257.70	0.00	242.30
1680-480-00-0000	Data Processing BOCES	538,845.00	-800.00	538,045.00	359,147.77	0.00	178,897.23
16 Central Services - State Function Group Subtotal		1,852,153.00	-5,356.34	1,846,796.66	1,151,326.08	133,327.04	662,143.54
1910-400-00-0000	Unallocated Insurance	92,551.00	0.00	92,551.00	73,959.23	0.00	18,591.77
1964-400-00-0000	Refund of Real Property	2,500.00	0.00	2,500.00	0.00	0.00	2,500.00
1981-480-00-0000	BOCES Admin. Charge	429,433.00	0.00	429,433.00	300,603.10	0.00	128,829.90
1983-480-00-0000	BOCES Capital Expense	192,184.00	0.00	192,184.00	134,528.80	0.00	57,655.20
19 Special Items (Contractual Expense) - State Function Group Subtotal		716,668.00	0.00	716,668.00	509,091.13	0.00	207,576.87
2010-480-00-0000	BOCES Curriculum Develop	36,613.00	0.00	36,613.00	20,053.62	0.00	16,559.38
2020-150-00-0000	Principals' Salaries-Elem	97,169.00	-2,719.00	94,450.00	72,757.60	21,692.40	0.00
2020-150-05-0000	Principals' Salaries-HS	127,720.00	3,950.00	131,670.00	98,250.00	30,820.00	2,600.00
2020-161-00-0000	Secretaries' Sal - Elem	40,367.00	575.50	40,942.50	31,245.60	9,696.90	0.00
2020-161-05-0000	Secretaries' Sal - HS	42,776.00	-1,806.50	40,969.50	31,245.40	9,373.55	350.55
2020-162-00-0000	Monitors' Salaries - K-5	4,288.00	0.00	4,288.00	2,313.76	1,642.70	331.54
2020-162-05-0000	Monitors' Salaries - 7-12	2,503.00	0.00	2,503.00	1,179.00	864.50	459.50
2020-400-00-0000	Super Other Exp - Elem	3,887.00	0.00	3,887.00	80.00	0.00	3,807.00
2020-400-00-1000	Prof Dev Other Elem	1,000.00	0.00	1,000.00	594.80	0.00	405.20
2020-400-05-0000	Super Other Exp - HS	5,109.00	-3,686.07	1,422.93	1,321.12	0.00	101.81

MADRID-WADDINGTON CSD

Budget Status Report As Of: 03/31/2026
Fiscal Year: 2026

Fund: A GENERAL FUND

Budget Account	Description	Initial Appropriation	Adjustments	Current Appropriation	Year-to-Date Expenditures	Encumbrance Outstanding	Unencumbered Balance
2020-400-05-1000	Prof Dev Other HS	1,000.00	3,624.28	4,624.28	4,624.28	0.00	0.00
2020-500-00-0000	Supervision Sup - Elem	750.00	611.79	811.79	811.79	0.00	0.00
2020-500-05-0000	Supervision Sup - HS	750.00	0.00	750.00	48.11	0.00	701.89
2060-400-00-0000	Grant Writer Services	14,000.00	0.00	14,000.00	12,000.00	2,000.00	0.00
20 Administration and Improvement - State Function Group Subtotal:		377,932.00	0.00	377,932.00	276,628.08	76,060.05	25,316.87
2110-110-00-0000	Teacher Salaries 1/2 Day	34,573.00	0.00	34,573.00	0.00	0.00	34,573.00
2110-110-01-0000	Teacher Salaries Pre-K	0.00	19,673.00	19,673.00	4,501.16	0.00	15,171.84
2110-120-00-0000	Teacher Salaries K-3	832,119.00	-40,673.00	891,446.00	521,491.20	338,716.11	31,238.69
2110-120-01-0000	TCH Salaries K-3 PROF DEV	15,000.00	0.00	15,000.00	9,150.00	0.00	5,850.00
2110-120-01-1000	TCH Sal Pre-K PROF Dev	1,000.00	0.00	1,000.00	1,000.00	0.00	0.00
2110-121-00-0000	4-5 ELEMENTARY TEACHERS	613,784.00	0.00	613,784.00	366,311.60	249,616.76	7,855.64
2110-121-01-0000	TCH Salaries 4-5 PROF DEV	7,500.00	0.00	7,500.00	7,000.00	0.00	500.00
2110-121-03-0000	6 ELEM TCH SALARIES	279,309.00	-200.00	279,109.00	159,392.45	117,021.30	2,695.25
2110-121-03-1000	6 Tch Prof Dev Stipends	1,500.00	200.00	1,700.00	1,700.00	0.00	0.00
2110-122-00-0000	K-3 ELEM TCH ASSISTANT	20,800.00	0.00	20,800.00	7,363.67	0.00	13,446.33
2110-122-00-1000	Pre-K TCH ASSISTANT	45,399.00	20,000.00	65,399.00	37,555.52	24,296.16	3,547.32
2110-123-00-0000	4-5 ELEM TCH ASSISTANT	8,240.00	0.00	8,240.00	2,700.00	0.00	5,540.00
2110-123-01-0000	6 TCH ASSISTANT	1,500.00	0.00	1,500.00	0.00	0.00	1,500.00
2110-130-00-0000	Teacher Salaries 7-12	1,582,048.00	-21,000.00	1,561,048.00	905,899.01	635,894.97	19,284.02
2110-130-01-0000	TCH Sal 7-12 PROF DEV	15,000.00	0.00	15,000.00	12,975.00	0.00	2,025.00
2110-131-00-0000	TCH ASSIST Salaries 7-12	4,680.00	1,500.00	6,180.00	3,687.75	1,692.25	800.00
2110-140-00-0000	Substitute Teachers - K-5	60,000.00	0.00	60,000.00	32,798.77	0.00	27,201.23
2110-140-00-1000	Substitute Tch -Pre-K	1,000.00	0.00	1,000.00	135.00	0.00	865.00
2110-140-02-0000	Substitute Teachers - 6	7,000.00	0.00	7,000.00	1,522.30	0.00	5,477.70
2110-140-03-0000	Substitute TCH - 7-12	115,485.00	20,000.00	135,485.00	118,821.77	0.00	16,663.23
2110-150-00-0000	Tutoring Salaries- K-3	5,000.00	0.00	5,000.00	0.00	0.00	5,000.00
2110-150-01-0000	Tutoring Salaries- 4-5	2,000.00	0.00	2,000.00	0.00	0.00	2,000.00
2110-150-02-0000	Tutoring Salaries- 6	1,000.00	500.00	1,500.00	1,260.00	0.00	240.00
2110-150-05-0000	Tutoring Salaries- 7-12	23,000.00	2,000.00	25,000.00	9,576.00	0.00	15,424.00
2110-160-00-0000	NON-INSTR SALARIES - K-5	1,700.00	0.00	1,700.00	0.00	0.00	1,700.00
2110-160-00-1000	NON-INSTR SALARIES Pre-K	1,000.00	0.00	1,000.00	0.00	0.00	1,000.00
2110-160-01-0000	NON-INSTR SALARIES 6	250.00	0.00	250.00	0.00	0.00	250.00
2110-160-05-0000	NON-INSTR SALARIES - 7-12	2,000.00	0.00	2,000.00	0.00	0.00	2,000.00
2110-200-00-0000	General Equipment K-12	27,000.00	-104.66	26,895.34	26,895.34	0.00	0.00
2110-400-00-0000	General Other Expense	23,000.00	-4,000.00	19,000.00	4,730.36	406.74	13,862.90
2110-400-01-0000	General Other Exp Pre-K	275.00	0.00	275.00	0.00	0.00	275.00
2110-400-01-1000	General Other Exp K-5	4,000.00	0.00	4,000.00	1,063.47	0.00	2,906.53
2110-400-03-0000	General Other Exp 6	425.00	0.00	425.00	0.00	0.00	425.00

MADRID-WASHINGTON CSD

Budget Status Report As Of: 03/31/2026

Fiscal Year: 2026

Fund: A GENERAL FUND

Budget Account	Description	Initial Appropriation	Adjustments	Current Appropriation	Year-to-Date Expenditures	Encumbrance Outstanding	Unencumbered Balance
2110-400-03-1700	PRE-K Teacher Conference	500.00	0.00	500.00	0.00	0.00	500.00
2110-400-03-1800	K-5 Teacher Conference	3,000.00	-3,000.00	0.00	0.00	0.00	0.00
2110-400-03-2000	6 Teacher Conference	750.00	0.00	750.00	0.00	0.00	750.00
2110-400-05-0000	General Other Exp 7-12	19,050.00	0.00	19,050.00	3,748.49	434.00	14,869.51
2110-400-05-1700	7-12 Teacher Conference	3,000.00	0.00	3,000.00	2,681.82	0.00	318.18
2110-470-00-0000	Tuition - K-5	23,000.00	-23,000.00	0.00	0.00	0.00	0.00
2110-470-03-1000	Tuition - 6	1,500.00	0.00	1,500.00	0.00	0.00	1,500.00
2110-470-03-1100	Tuition - 7-12	52,000.00	30,000.00	82,000.00	39,076.60	40,480.00	2,443.40
2110-480-03-0100	Textbooks K-5	15,000.00	-4,102.82	10,897.18	7,603.50	3,293.68	0.00
2110-480-03-0300	Textbooks 6	3,500.00	-874.54	2,625.46	1,694.47	830.99	0.00
2110-480-05-0100	Textbooks 7-12	13,000.00	729.11	13,729.11	11,013.81	2,715.30	0.00
2110-480-00-0000	BOCES Services	230,600.00	0.00	230,600.00	159,908.55	0.00	70,693.45
2110-500-00-0000	General K-12 Supplies	25,000.00	-4,082.31	20,917.69	16,841.83	0.00	4,075.86
2110-500-03-0000	General Pre-K Supplies	1,825.00	52.79	1,877.79	1,247.60	630.19	0.00
2110-500-03-0100	General K-5 Supplies	25,700.00	-52.79	25,647.21	21,167.75	984.90	3,514.56
2110-500-03-0120	General 6 Supplies	3,250.00	0.00	3,250.00	124.08	0.00	3,125.92
2110-500-05-0000	General 7-12 Supplies	27,950.00	0.00	27,950.00	19,870.80	623.66	7,455.54
2250-150-00-0000	Handicapped TCH SAL K-5	218,456.00	-5,000.00	213,456.00	123,405.96	89,275.57	774.47
2250-150-00-0100	Sub Hdcp Tch Sal K-5	2,500.00	0.00	2,500.00	681.80	0.00	1,818.20
2250-150-00-1000	Hdcp Tch Prof Dev K-5	3,500.00	0.00	3,500.00	2,500.00	0.00	1,000.00
2250-150-03-0100	Handicapped TCH SAL 6	65,055.00	-1,500.00	63,555.00	41,270.70	21,609.57	674.73
2250-150-03-0300	Sub Hdcp TCH SAL 6	750.00	0.00	750.00	740.70	0.00	9.30
2250-150-03-1100	Hdcp TCH SAL 6 Prof Dev	250.00	0.00	250.00	0.00	0.00	250.00
2250-150-05-0000	Handicapped TCH SAL 7-12	203,919.00	0.00	203,919.00	120,830.30	79,836.10	3,252.60
2250-150-05-0100	Sub Hdcp TCH SAL 7-12	3,000.00	0.00	3,000.00	1,102.50	0.00	1,897.50
2250-150-05-1000	Hdcp TchSal 7-12 Prof Dev	2,500.00	0.00	2,500.00	1,600.00	0.00	900.00
2250-151-00-0000	Hdcp Tch Asst K-5	148,743.00	35,000.00	183,743.00	125,231.48	58,650.72	1,860.80
2250-151-03-0100	Hdcp Tch Asst 6	20,698.00	-2,000.00	18,698.00	12,862.10	5,089.50	844.40
2250-151-05-0000	Hdcp Tch Asst 7-12	231,092.00	-27,000.00	204,092.00	126,096.67	76,147.30	1,848.03
2250-160-00-0000	Hdcp Noninstr Sal Pre-K	4,000.00	2,000.00	6,000.00	3,481.60	1,266.00	1,252.40
2250-160-01-0000	Hdcp Noninstr Sal K-5	3,500.00	-3,500.00	0.00	0.00	0.00	0.00
2250-160-03-0100	Hdcp Noninstr Sal 6	2,000.00	0.00	2,000.00	0.00	0.00	2,000.00
2250-160-05-0000	Hdcp Noninstr Sal 7-12	25,000.00	0.00	25,000.00	8,337.03	1,638.90	15,024.07
2250-200-00-0000	Hdcp Equip - K-5	5,000.00	-5,000.00	0.00	0.00	0.00	0.00
2250-200-05-0000	Hdcp Equip - 7-12	0.00	5,955.00	5,955.00	5,955.00	0.00	0.00
2250-400-00-0000	Hdcp Other Expense - K-5	135,000.00	0.00	135,000.00	30,697.20	400.00	104,002.80
2250-400-00-1000	Hdcp Prof Dev Other - K-5	2,500.00	0.00	2,500.00	144.00	0.00	2,356.00
2250-400-00-1100	Hdcp Other Exp - Pre-K	500.00	0.00	500.00	0.00	0.00	500.00
2250-400-03-0100	Hdcp Other Expense - 6	15,000.00	0.00	15,000.00	0.00	0.00	15,000.00

MADRID-WADDINGTON CSD

Budget Status Report As Of: 03/31/2026

Fiscal Year: 2026

Fund: A GENERAL FUND

Budget Account	Description	Initial Appropriation	Adjustments	Current Appropriation	Year-to-Date Expenditures	Encumbrance Outstanding	Unencumbered Balance
2250-400-03-1100	Hdcp Prof Dev Other - 6	250.00	0.00	250.00	0.00	0.00	250.00
2250-400-05-0000	Hdcp Other Expense - 7-12	45,000.00	-4,614.14	40,385.86	11,676.20	0.00	28,709.66
2250-400-05-1000	Hdcp Prof Dev Other 7-12	2,500.00	0.00	2,500.00	219.00	0.00	2,281.00
2250-470-00-0000	Handicapped tuition K-5	205,000.00	-13,057.14	191,942.86	52,625.00	52,625.00	86,692.86
2250-470-05-0000	Handicapped tuition 7-12	125,000.00	0.00	125,000.00	63,770.25	59,859.85	1,369.90
2250-490-00-0000	Handicapped BOCES Svces	1,270,000.00	-13,660.23	1,256,339.77	945,321.00	0.00	311,018.77
2250-500-00-0000	CSE Supplies	2,500.00	-1,503.00	997.00	684.49	0.00	312.51
2250-500-00-1000	CSE Supplies - UPK	1,000.00	-111.98	888.02	0.00	0.00	888.02
2250-500-03-0000	Handicapped K-5 Supplies	2,000.00	350.00	2,350.00	2,349.29	0.00	0.71
2250-500-03-0200	Handicapped 6 Supplies	3,500.00	-1,775.00	1,725.00	1,724.91	0.00	0.09
2250-500-05-0000	Handicapped 7-12 Supplies	4,000.00	7,654.12	11,654.12	11,654.12	0.00	0.00
2280-150-00-0000	Occ Ed Teacher Salaries	42,775.00	100.00	42,875.00	24,974.68	17,811.70	88.62
2280-150-00-0100	Sub Occ Ed Tch Salaries	500.00	-100.00	400.00	64.50	0.00	335.50
2280-150-00-1100	Occ Ed Prof Dev Tch Sal	1,000.00	0.00	1,000.00	1,000.00	0.00	0.00
2280-400-05-0000	General Occ Ed Other Exp	2,000.00	0.00	2,000.00	0.00	0.00	2,000.00
2280-490-00-0000	Occ Ed BOCES Services	651,210.00	0.00	651,210.00	450,430.75	0.00	200,779.25
2280-500-05-0000	General Occ Ed Supplies	1,500.00	0.00	1,500.00	0.00	0.00	1,500.00
2330-490-00-0000	BOCES Teaching Spec Sch	21,750.00	0.00	21,750.00	5,075.00	0.00	16,675.00
21 Teaching - State Function Group Subtotal		7,769,668.00	-34,297.69	7,725,380.41	4,688,701.90	1,879,847.22	1,166,811.29
2610-150-00-0000	Library InstrSal - K-5	58,704.00	-588.11	58,115.89	33,585.97	24,431.15	98.77
2610-150-00-0100	Sub Lib Instr Sal - K-5	500.00	559.51	1,059.51	1,059.51	0.00	0.00
2610-150-03-0200	Sub Lib InstrSal	500.00	0.00	500.00	0.00	0.00	500.00
2610-150-05-0000	Library InstrSal - 7-12	6,280.00	-61.21	6,218.79	3,051.79	2,220.10	946.90
2610-150-05-0100	Sub Library Tch Sal 7-12	0.00	89.81	89.81	89.81	0.00	0.00
2610-151-00-0000	LIB TCH ASSIST SAL - K-5	1,000.00	0.00	1,000.00	0.00	0.00	1,000.00
2610-400-00-0000	Lib & AV K-5 Other E	225.00	0.00	225.00	212.00	0.00	13.00
2610-400-03-0100	Lib & AV 6 Other E	75.00	0.00	75.00	0.00	0.00	75.00
2610-400-05-0000	Lib & AV 7-12 Other E	200.00	0.00	200.00	0.00	0.00	200.00
2610-480-00-0000	K-5 Library & AV Loan	3,000.00	0.00	3,000.00	2,998.99	0.00	1.01
2610-480-03-0100	6 Library & AV Loan	1,000.00	0.00	1,000.00	996.19	0.00	3.81
2610-480-05-0000	7-12 Library & AV Loan	4,000.00	0.00	4,000.00	3,825.22	136.13	38.65
2610-490-00-0000	Library & AV BOCES	46,170.00	0.00	46,170.00	32,334.66	0.00	13,835.44
2610-500-00-0000	Library & AV K-5 Supplie	750.00	44.08	794.08	794.08	0.00	0.00
2610-500-03-0100	Library & AV 6 Supplie	200.00	0.00	200.00	199.90	0.00	0.10
2610-500-05-0000	Library & AV 7-12 Supplie	800.00	-44.08	755.92	750.24	0.00	5.68
2630-200-01-0000	Equipment	40,000.00	4,506.00	44,506.00	0.00	0.00	44,506.00
2630-220-00-0000	State Aided Comput Hrdwre	16,000.00	4,348.25	20,348.25	8,141.76	6,015.00	6,191.49
2630-400-00-0000	Computer Other	2,500.00	12,000.00	14,500.00	5,177.97	1,600.00	7,722.03

MADRID-WADDINGTON CSD
Budget Status Report As Of: 03/31/2026
Fiscal Year: 2026

Fund: A GENERAL FUND

Budget Account	Description	Initial Appropriation	Adjustments	Current Appropriation	Year-to-Date Expenditures	Encumbrance Outstanding	Unencumbered Balance
2630-400-00-1000	Comp Prof Dev Other	3,500.00	7,057.14	10,557.14	9,937.14	620.00	0.00
2630-460-03-0000	K-5 Software	7,000.00	0.00	7,000.00	2,588.47	0.00	4,411.53
2630-460-05-0000	6-12 Software	7,000.00	0.00	7,000.00	3,286.48	0.00	3,713.52
2630-480-00-0000	Computer BOCES	105,000.00	13,660.23	118,660.23	118,660.23	0.00	0.00
2630-500-00-0000	Comp & STEAM Supplies K-5	35,000.00	-3,000.00	32,000.00	27,959.28	1,409.72	2,631.00
2630-500-05-0000	Comp & STEAM Sup. 6-12	35,000.00	-3,000.00	32,000.00	22,901.58	1,409.71	7,688.71
26 Instructional Media - State Function Group Subtotal		374,404.00	35,571.62	409,975.62	278,551.17	37,841.81	93,582.64
2805-160-00-0000	Attendance Salaries	37,262.00	0.00	37,262.00	19,613.70	14,383.30	3,265.00
2805-400-00-0000	Attendance Other Exp	600.00	0.00	600.00	0.00	0.00	600.00
2810-150-00-0000	Guidance Instr Sal K-5	74,344.00	0.00	74,344.00	43,512.90	30,481.10	350.00
2810-150-00-1000	Instructional Salaries	150.00	0.00	150.00	0.00	0.00	150.00
2810-150-00-1300	Guid Prof Dev 6	150.00	0.00	150.00	0.00	0.00	150.00
2810-150-03-0100	Guidance Instr Sal 6	50,511.00	0.00	50,511.00	28,820.11	18,610.68	3,080.21
2810-150-05-0000	Guidance Instr Sal 7-12	131,778.00	-7,616.94	124,161.06	66,925.59	42,664.12	14,571.35
2810-150-05-1000	Guid 7-12 Prof Dev	500.00	616.94	1,116.94	1,116.94	0.00	0.00
2810-160-00-0000	Guide Noninst Sal - K-5	1,000.00	0.00	1,000.00	0.00	0.00	1,000.00
2810-160-03-0100	Guide Noninst Sal - 6	6,012.00	0.00	6,012.00	2,771.77	448.63	2,791.60
2810-160-05-0000	Guide Noninst Sal - 7-12	20,435.00	0.00	20,435.00	10,867.31	2,128.09	7,439.60
2810-400-00-0000	Guidance Other Exp K-5	1,750.00	0.00	1,750.00	566.13	0.00	1,183.87
2810-400-03-0100	Guidance Other Exp 6	250.00	0.00	250.00	0.00	0.00	250.00
2810-400-05-0000	Guidance Other Exp 7-12	1,000.00	0.00	1,000.00	339.35	0.00	660.65
2810-500-00-0000	Guidance Supplies	250.00	0.00	250.00	81.61	0.00	168.39
2810-500-03-0000	Guidance Sup K-5	500.00	0.00	500.00	401.52	0.00	98.48
2810-500-03-0200	Guidance Sup 6	250.00	0.00	250.00	1.21	0.00	248.79
2810-500-05-0000	Guidance Supplies 7-12	750.00	0.00	750.00	67.25	0.00	682.75
2815-160-00-0000	health Service Sal	107,585.00	0.00	107,585.00	62,279.80	44,826.05	479.15
2815-400-00-0000	Health Services Other Exp	15,000.00	0.00	15,000.00	9,278.00	3,000.00	2,722.00
2815-500-00-0000	Health Services Supplies	5,000.00	0.00	5,000.00	4,908.94	0.00	91.06
2820-150-00-0000	Psychological Salaries	67,064.00	934.91	67,998.91	39,655.26	28,343.65	0.00
2820-150-00-1000	Psych. Sal. Prof Dev	1,500.00	709.82	2,209.82	2,209.82	0.00	0.00
2820-400-00-0000	Psychological Other	2,500.00	-500.00	2,000.00	727.30	0.00	1,272.70
2820-400-00-1000	Psych Prof Dev Other	500.00	0.00	500.00	0.00	0.00	500.00
2820-500-00-0000	Psychological Supplies	2,500.00	2,937.58	5,437.58	5,405.04	0.00	32.54
2850-150-00-0000	Cocurricular Sal. 7-12	70,554.00	7,281.20	77,835.20	27,487.00	50,096.20	252.00
2850-150-03-0000	After School Salaries K-5	18,000.00	0.00	18,000.00	2,912.00	4,137.00	10,951.00
2850-150-03-0100	After School Sal.	0.00	6,187.00	6,187.00	0.00	6,187.00	0.00
2850-150-03-0200	After School Sal. 6	1,000.00	279.80	1,279.80	1,279.80	0.00	0.00
2850-150-03-0300	Summer School Elem	25,000.00	-5,246.02	19,753.98	19,753.98	0.00	0.00

MADRID-WADDINGTON CSD

Budget Status Report As Of: 03/31/2026

Fiscal Year: 2026

Fund: A GENERAL FUND

Budget Account	Description	Initial Appropriation	Adjustments	Current Appropriation	Year-to-Date Expenditures	Encumbrance Outstanding	Unencumbered Balance
2850-150-05-0000	After School Prog 7-12	5,000.00	-2,279.80	2,720.20	2,487.12	0.00	233.08
2850-150-05-2000	Summer School 7-12	0.00	5,703.50	5,703.50	5,703.50	0.00	0.00
2850-400-00-0000	General Co. Other 7-12	1,500.00	1,660.00	3,160.00	3,160.00	0.00	0.00
2850-400-02-0000	Debate Other Expense	200.00	0.00	200.00	0.00	0.00	200.00
2850-400-03-0000	After School Other - K-5	1,000.00	-1,000.00	0.00	0.00	0.00	0.00
2850-400-03-0200	After School Other - 6	200.00	0.00	200.00	0.00	0.00	200.00
2850-400-03-0300	Summer School Other - Ele	500.00	0.00	500.00	400.00	0.00	100.00
2850-400-05-0000	After School Other - 7-12	500.00	305.00	805.00	801.35	0.00	3.65
2850-400-05-0200	Theatre Other	4,000.00	0.00	4,000.00	3,412.20	0.00	587.80
2850-500-00-0000	Cocur. General Sup. 7-12	500.00	0.00	500.00	0.00	0.00	500.00
2850-500-02-0000	Debate Supplies	750.00	0.00	750.00	0.00	0.00	750.00
2850-500-03-0000	After School Sup. K-5	1,500.00	-985.00	535.00	141.27	0.00	393.73
2850-500-03-0200	After School Sup. 6	300.00	0.00	300.00	0.00	0.00	300.00
2850-500-03-0300	Summer School Sup - Elem	5,000.00	880.49	5,880.49	5,880.49	0.00	0.00
2850-500-05-0000	After School Sup. 7-12	750.00	0.00	750.00	0.00	0.00	750.00
2850-500-05-0200	Theatre Supplies	7,500.00	0.00	7,500.00	4,057.79	354.41	3,087.80
2855-150-00-0000	Coaches' Salaries	143,072.00	0.00	143,072.00	91,995.80	48,740.70	4,335.50
2855-200-05-0100	Equipment - Uniforms	10,000.00	0.00	10,000.00	8,647.00	0.00	1,353.00
2855-200-05-1400	General Athletic Equipmen	7,500.00	0.00	7,500.00	0.00	0.00	7,500.00
2855-400-05-1400	General Athletic Other Ex	70,786.00	0.00	70,786.00	36,106.88	0.00	34,679.12
2855-490-00-0000	BOCES - Section X Coord	18,253.00	0.00	18,253.00	12,777.10	0.00	5,475.90
2855-500-05-1400	General Athletic Supplies	26,500.00	0.00	26,500.00	7,721.77	2,544.20	16,234.03
2855-500-05-1700	AED Supplies	2,500.00	0.00	2,500.00	1,466.46	0.00	1,033.54
28 Pupil Services - State Function Group Subtotal		951,506.00	9,868.48	961,374.48	636,721.06	294,945.13	130,708.29
5510-160-00-0000	Transportation Salaries	683,207.00	0.00	683,207.00	457,214.59	189,788.32	36,204.09
5510-160-00-1000	Transp Sal - Pre-K	33,027.00	0.00	33,027.00	19,218.91	4,560.81	9,247.28
5510-162-00-0000	Transp Office-Super Salar	120,221.00	1,793.85	122,014.85	93,453.60	28,561.05	0.00
5510-200-00-0000	Transportation Equipment	5,500.00	0.00	5,500.00	0.00	0.00	5,500.00
5510-210-00-0000	BUSES	245,000.00	0.00	245,000.00	234,645.19	0.00	10,354.81
5510-400-00-0000	Transportation Other Exp	20,000.00	-7,579.82	12,420.18	3,085.74	1,778.00	7,556.44
5510-400-00-1000	Transp Prof Dev Other Exp	750.00	0.00	750.00	0.00	0.00	750.00
5510-401-00-0000	Transportation Insurance	26,944.00	0.00	26,944.00	20,374.24	0.00	6,569.76
5510-490-00-0000	BOCES Transp. Services	5,904.00	0.00	5,904.00	3,781.80	0.00	2,122.20
5510-500-00-0000	Transportation Supplies	10,000.00	0.00	10,000.00	880.91	0.00	9,139.09
5510-570-00-0000	Transportation Parts	57,000.00	0.00	57,000.00	18,882.29	0.00	38,117.71
5510-571-00-0000	Transportation Gasoline	125,000.00	0.00	125,000.00	61,832.20	0.00	63,167.80
5510-572-00-0000	Trans Oil/Fluids/Def	9,000.00	0.00	9,000.00	2,029.47	0.00	6,970.53
5510-573-00-0000	Transportation Tires & Ch	15,000.00	0.00	15,000.00	6,770.68	0.00	8,229.32

MADRID-WADDINGTON CSD
Budget Status Report As Of: 03/31/2026
Fiscal Year: 2026

Fund: A GENERAL FUND

Budget Account	Description	Initial Appropriation	Adjustments	Current Appropriation	Year-to-Date Expenditures	Encumbrance Outstanding	Unencumbered Balance
5530-200-00-0000	Equipment	5,000.00	0.00	5,000.00	0.00	0.00	5,000.00
5530-400-00-0000	Bus Garage Other Expense	16,500.00	0.00	16,500.00	4,404.46	4,600.00	7,495.54
5530-410-00-0000	Bus Garage Insurance	15,595.00	0.00	15,595.00	14,101.61	0.00	1,493.39
5530-420-00-0000	Natural Gas	25,000.00	0.00	25,000.00	8,937.00	0.00	16,063.00
5530-470-00-0000	Garage Bldg Electricity	10,000.00	0.00	10,000.00	7,153.57	0.00	2,846.43
5530-500-00-0000	Bus Garage Supplies	5,500.00	0.00	5,500.00	1,019.94	0.00	4,480.06
5540-400-00-0000	Contract Transportation	25,000.00	0.00	25,000.00	4,804.80	5,790.40	14,404.80
55 Pupil Transportation - State Function Group Subtotal		1,459,148.00	-5,786.17	1,453,361.83	982,571.00	235,078.58	255,712.25
7140-150-00-0000	Fitness Center Instruc	4,720.00	0.00	4,720.00	2,360.00	2,360.00	0.00
7140-160-00-0000	Fitness Center Non-Instr	25,000.00	0.00	25,000.00	14,448.00	0.00	10,552.00
7140-200-00-0000	Fitness Center Equip	12,000.00	0.00	12,000.00	0.00	0.00	12,000.00
7140-400-00-0000	Fitness Center Other	2,500.00	0.00	2,500.00	668.05	0.00	1,831.95
7140-500-00-0000	Fitness center supplies	3,000.00	0.00	3,000.00	131.71	0.00	2,868.29
7 Community Services - State Function Group Subtotal		47,220.00	0.00	47,220.00	17,607.76	2,360.00	27,252.24
9010-800-00-0000	State Retirement	316,383.00	0.00	316,383.00	171,925.32	63,345.61	81,112.07
9020-800-00-0000	Teacher Retirement	553,529.00	0.00	553,529.00	310,429.19	193,559.63	49,540.18
9030-800-00-0000	Social Security	600,843.00	0.00	600,843.00	355,578.74	195,024.20	50,240.06
9040-800-00-0000	Workers' Compensation	48,290.00	0.00	48,290.00	33,243.82	0.00	15,046.18
9050-800-00-0000	Unemployment Insurance	10,000.00	0.00	10,000.00	0.00	0.00	10,000.00
9060-800-00-0000	Health Insurance	2,877,587.00	0.00	2,877,587.00	1,931,033.03	0.00	946,553.97
9060-800-00-1000	Health Ins. - Retirees	1,545,526.00	0.00	1,545,526.00	994,550.60	0.00	550,975.40
9060-810-00-0000	Dental Insurance	0.00	0.00	0.00	8,054.51	0.00	-8,054.51
9089-800-00-0000	Other Employee Benefits	37,111.00	0.00	37,111.00	19,766.81	79.95	17,264.24
90 Employee Benefits - State Function Group Subtotal		5,989,269.00	0.00	5,989,269.00	3,824,582.02	452,009.39	1,712,677.59
9711-600-00-0000	Building Bond Principal	745,000.00	0.00	745,000.00	0.00	0.00	745,000.00
9711-700-00-0000	Building Bond Interest	269,728.00	0.00	269,728.00	108,578.13	0.00	161,149.87
9731-600-00-0000	BAN Principal	42,500.00	0.00	42,500.00	42,500.00	0.00	0.00
9731-700-00-0000	BAN Interest	25,000.00	0.00	25,000.00	18,693.44	0.00	6,306.56
9770-700-00-0000	Revenue Anticipation Note	10,000.00	0.00	10,000.00	0.00	0.00	10,000.00
9788-600-00-0000	Principal	37,500.00	0.00	37,500.00	0.00	0.00	37,500.00
9788-700-00-0000	Interest	2,500.00	0.00	2,500.00	0.00	0.00	2,500.00
97 Debt Service - State Function Group Subtotal		1,132,228.00	0.00	1,132,228.00	169,771.57	0.00	962,456.43
9901-930-00-0000	Transfer to School Lunch	125,000.00	0.00	125,000.00	0.00	0.00	125,000.00
9901-950-00-0000	Transfer to Special	20,000.00	0.00	20,000.00	0.00	0.00	20,000.00
9950-900-00-0000	Transfer to Capital/Debt	100,000.00	0.00	100,000.00	100,000.00	0.00	0.00
99 Interfund Transfers - State Function Group Subtotal		245,000.00	0.00	245,000.00	100,000.00	0.00	145,000.00
Total GENERAL FUND		21,500,940.00	0.00	21,500,940.00	12,921,393.42	3,203,036.46	5,376,510.12

Madrid-Waddington Central School District
BUDGET REPORT
For The Period Ending March 31, 2026

Expenditures:

	<u>Original Approp</u>	<u>Adjustments</u>	<u>Total Approp</u>	<u>Expenditures</u>	<u>Encumb.</u>	<u>Available Balance</u>
Board of Education	\$ 138,401.00	\$ -	\$ 138,401.00	\$ 96,293.42	\$ 28,513.88	\$ 13,593.70
Central Administration	\$ 345,382.00	\$ (812.00)	\$ 344,570.00	\$ 237,615.99	\$ 57,995.16	\$ 48,958.85
Finance	\$ 70,926.00	\$ 812.00	\$ 71,738.00	\$ 53,857.49	\$ 5,028.20	\$ 12,852.31
Legal Services	\$ 41,045.00	\$ -	\$ 41,045.00	\$ 19,177.75	\$ -	\$ 21,867.25
Central Services	\$ 1,852,153.00	\$ (5,356.34)	\$ 1,846,796.66	\$ 1,151,326.08	\$ 133,327.04	\$ 562,143.54
Special Items	\$ 716,668.00	\$ -	\$ 716,668.00	\$ 509,091.13	\$ -	\$ 207,576.87
Instruction	\$ 9,483,500.00	\$ 11,142.51	\$ 9,474,642.51	\$ 5,779,499.21	\$ 2,288,724.21	\$ 1,406,419.09
Transportation	\$ 1,459,148.00	\$ (5,786.17)	\$ 1,453,361.83	\$ 962,571.00	\$ 235,078.58	\$ 255,712.25
Community Services	\$ 47,220.00	\$ -	\$ 47,220.00	\$ 17,607.76	\$ 2,360.00	\$ 27,252.24
Employee Benefits	\$ 5,989,269.00	\$ -	\$ 5,989,269.00	\$ 3,824,582.02	\$ 452,009.39	\$ 1,712,677.59
Debt Service	\$ 1,132,228.00	\$ -	\$ 1,132,228.00	\$ 169,771.57	\$ -	\$ 962,456.43
Interfund Transfers	\$ 245,000.00	\$ -	\$ 245,000.00	\$ 100,000.00	\$ -	\$ 145,000.00
	\$ 21,500,940.00	\$ 0.00	\$ 21,500,940.00	\$ 12,921,393.42	\$ 3,203,036.46	\$ 5,376,510.12

MADRID-WADDINGTON CSD
Revenue Status Report As Of: 03/31/2026
Fiscal Year: 2026
Fund: A GENERAL FUND

Revenue Account	Subfund	Description	Original Estimate	Adjustments	Current Estimate	Year-to-Date	Anticipated Balance	Excess Revenue
1001.000		Real Property Taxes	4,410,334.00	0.00	4,410,334.00	4,438,130.99		27,796.99
1081.000		Other Prmts in Lieu of Taxes	50,825.00	0.00	50,825.00	39,959.44	10,865.56	
1085.000		STAR Reimbursement	575,000.00	0.00	575,000.00	547,203.12	27,796.88	
1090.000		Int. & Penal. on Real Prop.Tax	7,000.00	0.00	7,000.00	7,218.84		218.84
1311.000		Other Day School Tuition (Indv	70,052.00	0.00	70,052.00	11,830.00	58,222.00	
2230.000		Day School Tuit-Oth Dist. NYS	0.00	0.00	0.00	79,379.50		79,379.50
2401.000		Interest and Earnings	12,000.00	0.00	12,000.00	44,929.54		32,929.54
2410.000		Rental of Real Property,Indiv.	0.00	0.00	0.00	701.25		701.25
2440.000		Rental of Buses	0.00	0.00	0.00	523.36		523.36
2650.000		Sale Scrap & Excess Material	1,000.00	0.00	1,000.00	500.00	500.00	
2665.000		Sale of Equipment	0.00	0.00	0.00	150.00		150.00
2666.000		Sale of Transportation Equip.	0.00	0.00	0.00	8,500.00		8,500.00
2680.000		Insurance Recoveries	0.00	0.00	0.00	843.52		843.52
2701.000		Refund PY Exp-BOCES Aided Srvc	190,000.00	0.00	190,000.00	0.00	190,000.00	
2703.000		Refund PY Exp-Other-Not Trans	500.00	0.00	500.00	0.00	500.00	
2704.000		Refund Pr Yr, Appv Priv Sch	0.00	0.00	0.00	9,373.69		9,373.69
2705.000		Gifts and Donations	185,600.00	0.00	185,600.00	185,600.00		
2770.000		Other Unclassified Rev.(Spec)	62,500.00	0.00	62,500.00	24,029.68	38,470.32	
3101.000		Basic Formula Aid-Gen Aids (Ex	9,426,365.00	0.00	9,426,365.00	6,569,840.65	2,856,524.35	
3101.100		Excess Cost Aid	1,200,000.00	0.00	1,200,000.00	867,410.50	332,589.50	
3101.200		Community Set Aside	100,000.00	0.00	100,000.00	0.00	100,000.00	
3102.000		Lottery Aid	800,000.00	0.00	800,000.00	875,186.16		75,186.16
3102.100		VLT Lottery Grants Aid	400,000.00	0.00	400,000.00	406,081.10		6,081.10
3102.200		Commercial Gaming Grant	55,000.00	0.00	55,000.00	48,357.04	6,642.96	
3102.300		Mobile Sports Wagering Funds	370,000.00	0.00	370,000.00	495,314.41		125,314.41
3102.400		Cannabis Revenue	2,000.00	0.00	2,000.00	0.00	2,000.00	
3103.000		BOCES Aid (Sect 3609a Ed Law)	1,400,000.00	0.00	1,400,000.00	348,614.00	1,051,386.00	
3260.000		Textbook Aid (Incl Txbk/Lott)	45,875.00	0.00	45,875.00	25,604.00	20,271.00	
3262.000		Computer Sftwre, Hrdwre Aid	12,360.00	0.00	12,360.00	20,799.00		8,409.00
3263.000		Library AV Loan Program Aid	4,200.00	0.00	4,200.00	3,831.00	389.00	
3289.000		Other State Aid	50,000.00	0.00	50,000.00	129,797.34		79,797.34
4601.000		Medic.Ass't-Sch Age-Sch Yr Pro	35,000.00	0.00	35,000.00	28,158.09	6,841.91	
5050.000		Interfund Trans. for Debt Svs	500,000.00	0.00	500,000.00	300,000.00	200,000.00	
Subfund Subtotal			19,965,641.00	0.00	19,965,641.00	15,517,866.22	4,902,979.48	455,204.70

* Estimated revenue for Carryover Encumbrances from the prior fiscal year will not be realized.

These are estimates to balance the budget

Madrid-Waddington Central School District
BUDGET REPORT
For The Period Ending March 31, 2026

Revenue:

	<u>Initial Est Rev</u>	<u>Adjustments</u>	<u>Current Est Rev</u>	<u>Actual Revenue</u>	<u>Variance</u>
Property Taxes	\$ 5,043,159.00	\$ -	\$ 5,043,159.00	\$ 5,032,512.39	\$ (10,646.61)
Tuition	\$ 70,052.00	\$ -	\$ 70,052.00	\$ 91,209.50	\$ 21,157.50
Interest & Earnings	\$ 12,000.00	\$ -	\$ 12,000.00	\$ 46,154.15	\$ 34,154.15
Sale of Scrap & Excess	\$ 1,000.00	\$ -	\$ 1,000.00	\$ 9,150.00	\$ 8,150.00
Insurance Recoveries	\$ -	\$ -	\$ -	\$ 843.52	\$ 843.52
Refund of Prior Yrs Exp	\$ 190,500.00	\$ -	\$ 190,500.00	\$ 9,373.69	\$ (181,126.31)
Gifts & Donations	\$ 185,600.00	\$ -	\$ 185,600.00	\$ 185,600.00	\$ -
Unclassified Revenues	\$ 62,500.00	\$ -	\$ 62,500.00	\$ 24,029.68	\$ (38,470.32)
Basic Aid	\$ 12,353,365.00	\$ -	\$ 12,353,365.00	\$ 9,262,189.86	\$ (3,091,175.14)
BOCES Aid	\$ 1,400,000.00	\$ -	\$ 1,400,000.00	\$ 348,614.00	\$ (1,051,386.00)
Other State Aid	\$ 147,465.00	\$ -	\$ 147,465.00	\$ 208,189.43	\$ 60,724.43
Appropriated Res FB	\$ 365,111.00	\$ -	\$ 365,111.00	\$ 365,111.00	\$ -
Interfund Transfer - Debt Service	\$ 500,000.00	\$ -	\$ 500,000.00	\$ 300,000.00	\$ (200,000.00)
Appropriated Fund Balance	\$ 1,170,188.00	\$ -	\$ 1,170,188.00	\$ 1,170,188.00	\$ -
	\$ 21,500,940.00	\$ -	\$ 21,500,940.00	\$ 17,053,165.22	\$ (4,447,774.78)

**School Lunch Fund
Monthly Analysis Worksheet
For the Period Ending March 31, 2026**

Beginning Fund Balance	\$57,510.88
Profit or (Loss)	(\$13,784.71)
Ending Fund Balance	<u><u>\$43,726.18</u></u>

Revenues

<i>Type A Sales</i>	
Breakfast	\$97.72
Lunch	\$1,404.18
<i>Other Sales</i>	
Breakfast	\$452.85
Lunch	\$4,445.02
Total Sales	\$6,399.77
<i>Federal Aid Receivable</i>	
Breakfast	\$12,718.00
Lunch	\$26,366.00
<i>State Aid Receivable</i>	
Breakfast	\$7,175.00
Lunch	\$14,573.00
Total Aid Receivable	\$60,832.00
<i>Surplus Food</i>	\$0.00
<i>Other Revenue</i>	\$0.00
Total Revenues	<u><u>\$67,231.77</u></u>

Expenses

<i>Beginning Food Inventory</i>	
Add: Purchases	\$28,704.22
Less: Ending Inventory	\$49,149.86
Food Used	\$28,807.75
<i>Beginning Federal Food Inventory</i>	
Add: Surplus Food	\$3,270.18
Less: Ending Inventory	\$0.00
Federal Food Used	\$2,867.05
Salary	\$18,437.71
Fringe Benefits	\$12,906.40
Other Expenses	\$0.00
<i>Beginning Supply Inventory</i>	
Add: Supplies Purchased	\$5,277.24
Less: Ending Inventory	\$522.51
Supplies Used	\$4,994.13
Total Expenses	<u><u>\$81,016.48</u></u>

Profit or (Loss) for Month **(\$13,784.71)**

**Madrid-Waddington Central School
Treasurer's Report
For The Period Ending March 31, 2026**

General Fund	319,651.25
School Lunch Fund	8,605.27
General Fund Checking Account	328,256.52
 Federal Fund Checking Account	 15,249.34
 Scholarship Account	 8,497.18
 Payroll Checking Account	 0.00
 Capital Fund Checking Account	 763,841.80
 General Fund Money Market Account - Chase Bank @ 1.17%	
General Fund Savings	4,129,301.46
Unemployment	42,879.89
Insurance Reserve	815,173.32
Building Reserve	1,147,463.96
Employee Benefit Reserve	204,409.55
Retirement Reserve - TRS	76,952.49
Transportation & Equipment Reserve	749,739.82
School Lunch	44,910.00
Federal Fund	110,448.53
Debt Service	758,104.22
Capital Fund	1,778,864.32
Chase Money Market Account	9,858,247.56
 Fidelity Investment - Scholarship Account	 10,374.84

Madrid-Waddington Central School District
 Quarterly Report of Reserves
 Three Month Period Ending March 31, 2026
 Fiscal Year Ending June 30, 2026

Name of Reserve	Reserve Description	Ending Balance	Intended Use of the Reserve in the 2025-2026 School Year
Restricted Fund Balance Unemployment Reserve	Established for payment of unemployment claims.	\$42,879.89	No activity – interest earnings only. At the current time, the district intends to use a portion of the reserve to offset claims paid in 2025-2026.
Restricted Fund Balance Insurance Reserve	Established for payment of insurance cost	\$815,173.32	No activity - interest earnings only. At the current time, the district intends to use a portion of the reserve to offset future insurance cost or change of insurance plans.
Restricted Fund Balance Reserve for Employee Benefits	Established to pay accrued benefits due employees upon termination of service for vacation, sick leave, personal leave, etc.	\$204,409.55	No activity - interest earnings only. At the current time, the district intends to use a portion of the reserve to offset benefits paid to retirees per contractual language in 2025-26.

<p>Restricted Fund Balance</p> <p>Retirement Reserve</p> <p>TRS</p>	<p>Established to pay future retirement system payments</p>	<p>\$76,952.49</p>	<p>No activity - interest earnings only. At the current time, the district intends to use a portion of the reserve to offset future retirement system invoices.</p>
<p>Restricted Fund Balance</p> <p>Reserve for Capital - Building</p>	<p>Established to pay the cost of any object or purpose for which bonds may be issued.</p>	<p>\$1,147,463.96</p>	<p>Voter approved 10/18/23 - 10 yrs - \$3,000,000. No activity - interest earnings only. The district intends to use a portion of future deposits to offset future building improvements.</p>
<p>Restricted Fund Balance</p> <p>Reserve for Capital – Transportation or Equipment</p>	<p>Established to pay the cost of any object or purpose for which bonds may be issued.</p>	<p>\$749,739.82</p>	<p>Voter approved 10/18/23 - 10 yrs - \$2,000,000. No activity - interest earnings only. At the current time, the district intends to use a portion of the reserve to offset future equipment purchases.</p>
<p>Restricted Fund Balance</p>	<p>Portion of Assigned Fund Balance that is held in trust by other Agents</p>	<p>\$1,170,188</p>	<p>The district carried \$1,170,188 into 2025-2026. This was a decrease of \$134,812 from 2024-25.</p>

Mandatory Reserve for Debt Service	To cover debt service payments on outstanding obligations after the sale of district capital assets.	\$758,104.22	The general fund transferred \$600,000 back to the reserve. At this current time, the district intends to use a portion of the reserve as payment of the debt obligations due in 2025-2026.
-------------------------------------------	------------------------------------------------------------------------------------------------------	--------------	---------------------------------------------------------------------------------------------------------------------------------------------------------------------------------------------

**Recommended
PERSONNEL ACTIONS
April 20, 2026**

Name	Tenure Area	Assignment	Type of Appointment	Effective Date	Salary
Appointment					
Diane Burns		Substitute Food Service Worker	Annual	April 13, 2026	\$17/hr
Diane Burns		Substitute Keyboard Specialist	Annual	April 13, 2026	\$19.50/hr
Diane Burns		Substitute Teaching Asst.	Annual	April 13, 2026	\$135/day
Taylor Putney, RN		Substitute Nurse	Annual	April 21, 2026	\$160/day

I recommend the foregoing personnel actions:

April 16, 2026
Eric Burke

Section 10 Athletics

COMBINED TEAMS APPLICATION

1. Describe the reason(s) for this request and any history that will help demonstrate need:
 Lisbon Central School does not offer golf.

2. List all schools considered: Indicate their anticipated number of participants and league record for the previous year.

HOST SCHOOL	BEDs # (9-11 only)	Current # of Players	Total # of Players Last Season
Madrid Waddington	126		
REQUESTING SCHOOL	BEDs # (9-11 only)	Current # of Players	Total # of Players Last Season
Lisbon Central School	125	3	1

Original Team Classification/Division
 Class D

Classification/Division With Combined School(s)
 Class D

3. What name will the team use? Madrid-Waddington

4. Which Athletic Director is responsible for the team? Brenda McCall

What, if any, are the financial obligations to the host school? No additional cost

What, if any, are the financial obligations of the requesting school? Fees based on Merger Fee Schedule – Does not charge

***NOTE:** Financial obligations, if any, will be paid directly by the school or a school organization.*

5. Which school will be responsible for awards? Madrid-Waddington

Which school will be responsible for practice and game transportation? Madrid-Waddington for games only

Which school will be responsible for the coach? Madrid-Waddington

6. Which facility will be used for practices and contests? Madrid-Waddington

7. Do the schools involved participate in the Advanced Placement Process? If one or more do not, please explain procedure to be used. (use back of form) Yes

The following schools: 1. Lisbon Central School 2. Madrid-Waddington Central
 3. _____ 4. _____

have agreed, with the Board of Education approval, to combine in the sport of:

Golf at the ALL Level, during the 2026-2027 school year.
 (Boys only, Girls only) (Both) (MOD, JV, VAR)

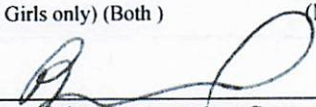

 Signature of the **Requesting** Superintendent*

3/23/26

 Date

 Signature of the **Host** Superintendent

 Date

Section 10 Athletics

COMBINED TEAMS APPLICATION

1. Describe the reason(s) for this request and any history that will help demonstrate need:
Lisbon Central School does not offer volleyball.

2. List all schools considered: Indicate their anticipated number of participants and league record for the previous year.

HOST SCHOOL	BEDs # (9-11 only)	Current # of Players	Total # of Players Last Season
Madrid Waddington	126	Unknown	Unknown
REQUESTING SCHOOL	BEDs # (9-11 only)	Current # of Players	Total # of Players Last Season
Lisbon Central School	125	4	4

Original Team Classification/Division	Classification/Division With Combined School(s)
Class D	Class C - Class D (Volleyball)

3. What name will the team use? Madrid-Waddington

4. Which Athletic Director is responsible for the team? Brenda McCall

What, if any, are the financial obligations to the host school? No additional cost

What, if any, are the financial obligations of the requesting school? Fees based on Merger Fee Schedule – Does not charge

***NOTE:** Financial obligations, if any, will be paid directly by the school or a school organization.*

5. Which school will be responsible for awards? Madrid-Waddington

Which school will be responsible for practice and game transportation? Madrid-Waddington for games only

Which school will be responsible for the coach? Madrid-Waddington

6. Which facility will be used for practices and contests? Madrid-Waddington

7. Do the schools involved participate in the Advanced Placement Process? If one or more do not, please explain procedure to be used. (use back of form) Yes

The following schools: 1. Lisbon Central School 2. Madrid-Waddington Central
 3. _____ 4. _____

have agreed, with the Board of Education approval, to combine in the sport of:
Volleyball at the all Level, during the 2026-2027 school year.
 (Boys only, Girls only) (Both) (MOD, JV, VAR)

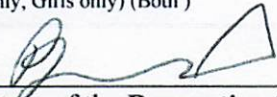

 Signature of the **Requesting** Superintendent*

3/23/26

 Date

 Signature of the **Host** Superintendent

 Date

Section 10 Athletics

COMBINED TEAMS APPLICATION (Varsity Only)

1. Describe the reason(s) for this request and any history that will help demonstrate need:
Madrid-Waddington Central School does not offer this sport, therefore we would like our students to have the opportunity to participate in their sports of choice.

2. Indicate the anticipated number of participants and league record for the previous year.

HOST SCHOOL	Classification #	Current # of Players	Total # of Players Last Season
Canton Central School			
REQUESTING SCHOOL	Classification #	Current # of Players	Total # of Players Last Season
Madrid- Waddington Central School			

3. What name will the team use? Canton Central School

4. Which Athletic Director is responsible for the team? Canton Central School/Ben Geiger

What, if any, are the financial obligations to the **host** school? Standard operating costs

What, if any, are the financial obligations of the **requesting** school? Merger fee per student

***NOTE:** Financial obligations, if any, will be paid directly by the school or a school organization.*

5. Which school will be responsible for awards? Canton Central School

Which school will be responsible for game/contest transportation? Canton Central School
 (The host school is not responsible for transportation to/from practices.)

Which school will be responsible for the coach? Canton Central School

6. Which facility will be used for practices and contests? Canton Central School

7. Do the schools involved participate in the Advanced Placement Process? If one or more do not, please explain procedure to be used. (use back of form)

The following schools: 1. Canton Central School 2. Madrid- Waddington Central School
 have agreed, with Board of Education approval, to combine in

<u>Boys</u>	<u>Football (modified, jv, varsity)</u>	<u>2026-2027</u>
(Boys, Girls, Both)	Sport	School Year

 Signature of the **Requesting** Superintendent*

 Date

 Signature of the **Host** Superintendent

 Date

Section 10 Athletics

COMBINED TEAMS APPLICATION (Varsity Only)

1. Describe the reason(s) for this request and any history that will help demonstrate need:
 Madrid-Waddington Central School does not offer this sport, therefore we would like our students to have the opportunity to participate in their sports of choice.

2. Indicate the anticipated number of participants and league record for the previous year.

HOST SCHOOL	Classification #	Current # of Players	Total # of Players Last Season
Canton Central School			
REQUESTING SCHOOL	Classification #	Current # of Players	Total # of Players Last Season
Madrid- Waddington Central School			

3. What name will the team use? Canton Central School

4. Which Athletic Director is responsible for the team? Canton Central School/Ben Geiger

What, if any, are the financial obligations to the **host** school? Standard operating costs

What, if any, are the financial obligations of the **requesting** school? Merger fee per student

***NOTE:** Financial obligations, if any, will be paid directly by the school or a school organization.*

5. Which school will be responsible for awards? Canton Central School

Which school will be responsible for game/contest transportation? Canton Central School
 (The host school is not responsible for transportation to/from practices.)

Which school will be responsible for the coach? Canton Central School

6. Which facility will be used for practices and contests? Canton Central School

7. Do the schools involved participate in the Advanced Placement Process? If one or more do not, please explain procedure to be used. (use back of form)

The following schools: 1. <u>Canton Central School</u> 2. <u>Madrid- Waddington Central School</u>		
have agreed, with Board of Education approval, to combine in		
<u>Both</u>	<u>Cross-Country (modified, varsity)</u>	<u>2026-2027</u>
(Boys, Girls, Both)	Sport	School Year

Signature of the **Requesting** Superintendent*

Date

Signature of the **Host** Superintendent

Date

Section 10 Athletics

COMBINED TEAMS APPLICATION (Varsity Only)

1. Describe the reason(s) for this request and any history that will help demonstrate need:
Madrid-Waddington Central School does not offer this sport, therefore we would like our
students to have the opportunity to participate in their sports of choice.

2. Indicate the anticipated number of participants and league record for the previous year.

HOST SCHOOL	Classification #	Current # of Players	Total # of Players Last Season
Canton Central School			
REQUESTING SCHOOL	Classification #	Current # of Players	Total # of Players Last Season
Madrid- Waddington Central School			

3. What name will the team use? Canton Central School

4. Which Athletic Director is responsible for the team? Canton Central School/Ben Geiger

What, if any, are the financial obligations to the **host** school? Standard operating costs

What, if any, are the financial obligations of the **requesting** school? Merger fee per student

***NOTE:** Financial obligations, if any, will be paid directly by the school or a school organization.*

5. Which school will be responsible for awards? Canton Central School

Which school will be responsible for game/contest transportation? Canton Central School
 (The host school is not responsible for transportation to/from practices.)

Which school will be responsible for the coach? Canton Central School

6. Which facility will be used for practices and contests? Canton Central School

7. Do the schools involved participate in the Advanced Placement Process? If one or more do not, please explain procedure to be used. (use back of form)

The following schools: 1. <u>Canton Central School</u> 2. <u>Madrid- Waddington Central School</u>		
have agreed, with Board of Education approval, to combine in		
<u>Both</u>	<u>Swimming (modified,varsity)</u>	<u>2026-2027</u>
(Boys, Girls, Both)	Sport	School Year

 Signature of the **Requesting** Superintendent*

 Date

 Signature of the **Host** Superintendent

 Date

Section 10 Athletics

COMBINED TEAMS APPLICATION (Varsity Only)

1. Describe the reason(s) for this request and any history that will help demonstrate need:
 Madrid-Waddington Central School does not offer this sport, therefore we would like our students to have the opportunity to participate in their sports of choice.

2. Indicate the anticipated number of participants and league record for the previous year.

HOST SCHOOL	Classification #	Current # of Players	Total # of Players Last Season
Canton Central School			
REQUESTING SCHOOL	Classification #	Current # of Players	Total # of Players Last Season
Madrid- Waddington Central School			

3. What name will the team use? Canton Central School

4. Which Athletic Director is responsible for the team? Canton Central School/Ben Geiger

What, if any, are the financial obligations to the **host** school? Standard operating costs

What, if any, are the financial obligations of the **requesting** school? Merger fee per student

***NOTE:** Financial obligations, if any, will be paid directly by the school or a school organization.*

5. Which school will be responsible for awards? Canton Central School

Which school will be responsible for game/contest transportation? Canton Central School
 (The host school is not responsible for transportation to/from practices.)

Which school will be responsible for the coach? Canton Central School

6. Which facility will be used for practices and contests? Canton Central School

7. Do the schools involved participate in the Advanced Placement Process? If one or more do not, please explain procedure to be used. (use back of form)

The following schools: 1. <u>Canton Central School</u> 2. <u>Madrid- Waddington Central School</u>		
have agreed, with Board of Education approval, to combine in		
<u>Both</u>	<u>Indoor Track (modified,varsity)</u>	<u>2026-2027</u>
(Boys, Girls, Both)	Sport	School Year

 Signature of the **Requesting** Superintendent*

 Date

 Signature of the **Host** Superintendent

 Date

Section 10 Athletics

COMBINED TEAMS APPLICATION (Varsity Only)

1. Describe the reason(s) for this request and any history that will help demonstrate need:
Madrid-Waddington Central School does not offer this sport, therefore we would like our students to have the opportunity to participate in their sports of choice.

2. Indicate the anticipated number of participants and league record for the previous year.

HOST SCHOOL	Classification #	Current # of Players	Total # of Players Last Season
Canton Central School			
REQUESTING SCHOOL	Classification #	Current # of Players	Total # of Players Last Season
Madrid- Waddington Central School			

3. What name will the team use? Canton Central School

4. Which Athletic Director is responsible for the team? Canton Central School/Ben Geiger

What, if any, are the financial obligations to the **host** school? Standard operating costs

What, if any, are the financial obligations of the **requesting** school? Merger fee per student

***NOTE:** Financial obligations, if any, will be paid directly by the school or a school organization.*

5. Which school will be responsible for awards? Canton Central School

Which school will be responsible for game/contest transportation? Canton Central School
 (The host school is not responsible for transportation to/from practices.)

Which school will be responsible for the coach? Canton Central School

6. Which facility will be used for practices and contests? Canton Central School

7. Do the schools involved participate in the Advanced Placement Process? If one or more do not, please explain procedure to be used. (use back of form)

The following schools: 1. <u>Canton Central School</u> 2. <u>Madrid- Waddington Central School</u>		
have agreed, with Board of Education approval, to combine in		
Girls	Ice Hockey	2026-2027
(Boys, Girls, Both)	Sport	School Year

 Signature of the **Requesting** Superintendent*

 Date

 Signature of the **Host** Superintendent

 Date

Section 10 Athletics

COMBINED TEAMS APPLICATION (Varsity Only)

1. Describe the reason(s) for this request and any history that will help demonstrate need:
Madrid-Waddington Central School does not offer this sport, therefore we would like our
students to have the opportunity to participate in their sports of choice.

2. Indicate the anticipated number of participants and league record for the previous year.

HOST SCHOOL	Classification #	Current # of Players	Total # of Players Last Season
Canton Central School			
REQUESTING SCHOOL	Classification #	Current # of Players	Total # of Players Last Season
Madrid- Waddington Central School			

3. What name will the team use? Canton Central School

4. Which Athletic Director is responsible for the team? Canton Central School/Ben Geiger

What, if any, are the financial obligations to the **host** school? Standard operating costs

What, if any, are the financial obligations of the **requesting** school? Merger fee per student

***NOTE:** Financial obligations, if any, will be paid directly by the school or a school organization.*

5. Which school will be responsible for awards? Canton Central School

Which school will be responsible for game/contest transportation? Canton Central School
 (The host school is not responsible for transportation to/from practices.)

Which school will be responsible for the coach? Canton Central School

6. Which facility will be used for practices and contests? Canton Central School

7. Do the schools involved participate in the Advanced Placement Process? If one or more do not, please explain procedure to be used. (use back of form)

The following schools: 1. <u>Canton Central School</u> 2. <u>Madrid- Waddington Central School</u>		
have agreed, with Board of Education approval, to combine in		
<u>Both</u>	<u>Wrestling (modified, varsity)</u>	<u>2026-2027</u>
(Boys, Girls, Both)	Sport	School Year

 Signature of the **Requesting** Superintendent*

 Date

 Signature of the **Host** Superintendent

 Date

Section 10 Athletics

COMBINED TEAMS APPLICATION (Varsity Only)

1. Describe the reason(s) for this request and any history that will help demonstrate need:
Madrid-Waddington Central School does not offer this sport, therefore we would like our
students to have the opportunity to participate in their sports of choice.

2. Indicate the anticipated number of participants and league record for the previous year.

HOST SCHOOL	Classification #	Current # of Players	Total # of Players Last Season
Canton Central School			
REQUESTING SCHOOL	Classification #	Current # of Players	Total # of Players Last Season
Madrid- Waddington Central School			

3. What name will the team use? Canton Central School

4. Which Athletic Director is responsible for the team? Canton Central School/Ben Geiger

What, if any, are the financial obligations to the **host** school? Standard operating costs

What, if any, are the financial obligations of the **requesting** school? Merger fee per student

***NOTE:** Financial obligations, if any, will be paid directly by the school or a school organization.*

5. Which school will be responsible for awards? Canton Central School

Which school will be responsible for game/contest transportation? Canton Central School
 (The host school is not responsible for transportation to/from practices.)

Which school will be responsible for the coach? Canton Central School

6. Which facility will be used for practices and contests? Canton Central School

7. Do the schools involved participate in the Advanced Placement Process? If one or more do not, please explain procedure to be used. (use back of form)

The following schools: 1. <u>Canton Central School</u> 2. <u>Madrid- Waddington Central School</u>		
have agreed, with Board of Education approval, to combine in		
<u>Both</u>	<u>Lacrosse (modified, varsity)</u>	<u>2026-2027</u>
(Boys, Girls, Both)	Sport	School Year

 Signature of the **Requesting** Superintendent*

 Date

 Signature of the **Host** Superintendent

 Date

BUDGET BREAKDOWN

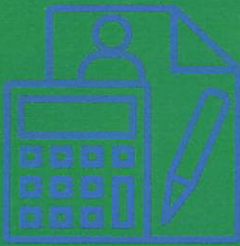

The St. Lawrence-Lewis Counties School District Employees Medical Plan has converted the Medicare primary retirees over to an Employee Group Waiver Program (EGWP). This new structure will allow the plan to take advantage of federally negotiated RX rates and rebates while retaining the benefit control of the plan. As a member of the plan, BOCES should experience lower premium increases in the future due to the EGWP conversion.

Retiree healthcare comprises over 3/4 of the administrative budget. By coding these costs to the admin budget, the cost for all retirees is shared and eligible for BOCES aid. It also ensures that we are in compliance with SED regulations.

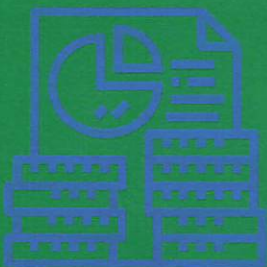

The administrative budget supports the cost of all BOCES central offices, including the business office, the department of human resources and central administration.

UNDERSTANDING THE ADMINISTRATIVE BUDGET

ST. LAWRENCE-LEWIS BOCES

BOCES provide shared educational programs and services to school districts across the state. Sharing services through BOCES is an economical way for districts to provide cost-effective programming that is still rich in quality. BOCES is an Educational Service Agency (ESA), not a school district. Consequently, it operates and is funded in a different way.

The BOCES budget differs from school district budgets in that it is a series of separate budgets. The administrative budget represents approximately 13.8% of the total BOCES budget. 76% of the administrative budget consists of retiree costs. The administrative budget for 2026-27 will increase by 3.4%. Component districts only vote on the administrative budget. With the exception of the administrative budget, all other BOCES charges reflect services each district has selected.

Component school districts "vote" on the rest of the proposed budget by deciding whether or not to participate in BOCES services. Most of the budget is an estimate based on the interest of districts in services. The funds spent will increase or decrease depending on district participation. The only other part of the budget that districts do not vote on is the capital budget, which includes rental fees for facilities. By law, the capital budget is not submitted to vote, rather, it is part of the annual assessment that districts pay to BOCES.

KEEPING THE COSTS DOWN

For 2026-27, the administrative budget comprises 13.80% of the total BOCES budget. The BOCES has reconfigured staffing structures whenever possible instead of making new hires.

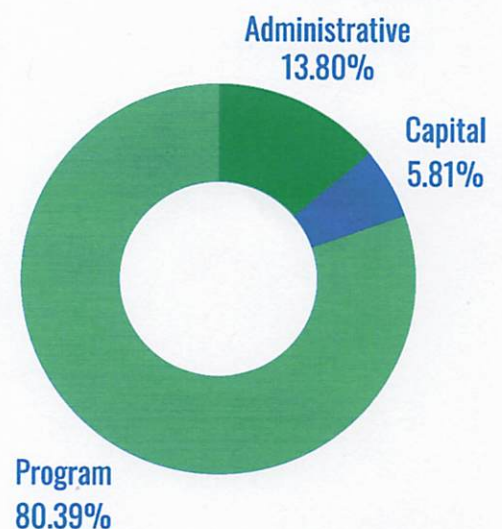



Darin Saiff
District Superintendent
Educational Services Center
Phone: (315) 386-4504 Ext. 10150
Email: darin.saiff@sllboces.org

ADMINISTRATIVE BUDGET - CERTIFICATION FORM

I, _____, District Clerk of the _____ School District do hereby certify that at a public meeting held on **Monday, April 20, 2026**, the Board of Education of the _____ School District adopted a resolution casting its vote for the adoption of the **2026-2027 Administrative Budget** for the Board of Cooperative Educational Services by placing an "X" in the box below.

- Yes for the 2026-2027 Administrative Budget - \$10,279,948
- No for the 2026-2027 Administrative Budget - \$10,279,948

Yeas: (Please list names)

Nays: (Please list names)

Signature – District Clerk

Date

**40 W. MAIN STREET
PO BOX 231
CANTON, NY 13617
[HTTPS://WWW.SLLBOCES.ORG/](https://www.sllboces.org/)**

Notice of BOCES Annual Meeting
St. Lawrence-Lewis BOCES

Please take notice that the BOARD OF COOPERATIVE EDUCATIONAL SERVICES OF THE SOLE SUPERVISORY DISTRICT OF THE ST. LAWRENCE-LEWIS COUNTIES BOCES will hold the annual meeting of the trustees and members of the boards of education of its component school districts on Wednesday, April 1, 2026 at 6:00 P.M. at the St. Lawrence-Lewis BOCES Educational Services Center, 40 West Main Street, Canton, New York, Conference Room A. The Board of Cooperative Educational Services will present its tentative administrative, capital and program budgets for 2026-2027 to the trustees and members of the boards of education of component school districts in attendance at such annual meeting, for their review.

The following are summaries of the tentative administrative, capital, and program budgets. The amounts stated are based on current estimates and may be subject to change. Copies of the complete tentative administrative, capital and program budgets will be available for inspection by the public between the hours of 9:00 A.M. and 4:00 P.M. at each component school district in the St. Lawrence-Lewis Counties BOCES Sole Supervisory District, St. Lawrence-Lewis BOCES Central Office, 40 West Main Street, Canton; Seaway Career & Technical Center, 7225 ST HWY 56, Norwood; Northwest Career & Technical Center, 1000 Park Street, Ogdensburg; and Southwest Career & Technical Center, 3606 ST HWY 58, Gouverneur, commencing on March 25, 2026.

SUMMARY OF TENTATIVE ADMINISTRATIVE BUDGET

TOTAL PERSONNEL SERVICES (salaries of all central administrative and supervisory personnel): \$1,109,129; TOTAL EMPLOYEE BENEFITS (benefits of all central administrative and supervisory personnel): \$8,395,990; EQUIPMENT: \$7,499; SUPPLIES and MATERIALS: \$10,700; REVENUE NOTE INTEREST: \$235,000; TOTAL CONTRACT EXPENSE: \$257,405; NET TRANSFERS (other than capital): \$264,225.

TOTAL ADMINISTRATIVE BUDGET \$10,279,948

SUMMARY OF TENTATIVE CAPITAL BUDGET

RENTAL OF FACILITIES: \$419,000; ENERGY DEBT SERVICE: \$112,972; DEBT SERVICE-DORMITORY AUTHORITY: \$2,962,300; TRANSFER TO CAPITAL FUND: \$835,000.

TOTAL CAPITAL BUDGET \$4,329,272

SUMMARY OF TENTATIVE PROGRAM BUDGET

OCCUPATIONAL INSTRUCTION: \$14,690,682; INSTRUCTION OF STUDENTS WITH DISABILITIES: \$24,685,248; ITINERANT SERVICES: \$2,443,489; GENERAL INSTRUCTION: \$1,494,065; INSTRUCTIONAL SUPPORT: \$10,254,445; OTHER SERVICES: \$6,313,497.

TOTAL PROGRAM BUDGET \$59,881,426

2026-27 compensation of the District Superintendent of Schools is estimated as follows:
STATE SALARY: \$43,499; BOCES SALARY: \$164,751; ANNUALIZED BENEFITS: \$58,120;
OTHER REMUNERATION: \$3,836; TOTAL COMPENSATION OF DISTRICT SUPERINTENDENT (including benefits): \$270,206.

**BOARD OF COOPERATIVE EDUCATIONAL SERVICES OF THE
SOLE SUPERVISORY DISTRICT OF THE COUNTIES OF
ST. LAWRENCE-LEWIS**

BALLOT FOR ELECTION TO BOARD OF COOPERATIVE EDUCATIONAL SERVICES

There are **three (3) vacancies** on the board of cooperative educational services to be filled at the annual election to be held on Monday, April 20, 2026 or at the next regularly scheduled meeting. The trustees or board of education of each component school district, by resolution, may cast one vote for each vacancy to be filled, provided that no more than one vote may be cast for any candidate. No more than one person residing in a particular component school district may be elected to serve on the board of cooperative educational services at one time, except as provided in Education Law 1950(2a). The district clerk or other officer authorized to certify that a board resolution has been adopted, shall complete the ballot by placing an "X" next to the name of each candidate for whom a vote has been cast, and by completing the certification below.

Candidates are listed in alphabetical order with their address and school district of residence.

- | | | |
|-------------------------------------|--------------------------------------------------------------------------------|--------------------------|
| 1. Candidate Name
Address | Todd Bates
55 Valley Drive
Gouverneur, New York 13642 | <input type="checkbox"/> |
| (School District) | Gouverneur Central School District | |
| | | |
| 2. Candidate Name
Address | Michael Miller
PO Box 564
59 Fenton Street
Waddington, New York 13694 | <input type="checkbox"/> |
| (School District) | Madrid-Waddington Central School District | |
| | | |
| 3. Candidate Name
Address | Kevin Wells
PO Box 136
286 Olds Mill Road
Morristown, New York 13664 | <input type="checkbox"/> |
| (School District) | Morristown Central School District | |

CERTIFICATION

I, _____, District Clerk of the _____ School District do hereby certify that at a public meeting held Monday, April 20, 2025, or at the next regularly scheduled meeting, the Board of Education of the _____ School District adopted a resolution casting its vote or votes in the annual election of members of the Board of Cooperative Educational Services for the person or persons indicated on the above ballot.

Signature - District Clerk

Print Name

Date

ADMINISTRATION

JACQUELYN L. KELLY
SUPERINTENDENT OF SCHOOLS
(315) 287-4870

JESSICA SULLIVAN
ASSISTANT SUPERINTENDENT
(315) 287-4870

DALE R. MUNN JR.
BUSINESS MANAGER
(315) 287-4836

**GOVERNEUR CENTRAL
SCHOOL DISTRICT**

133 East Barney Street
Gouverneur, New York 13642

FAX: (315) 287-4736

<http://www.gcsk12.org>

Delivering the Promise of a Brighter Future

BOARD OF EDUCATION

DAVID FENLONG
PRESIDENT
TODD E. BATES
VICE-PRESIDENT
BROOKE BUSH
DR. WILLIAM CARTWRIGHT
TINA FRENCH
LISA MCGREGOR
NICKOLAS ORMASEN
LAURIE M. ROBERTS
LAURA SPICER

February 10, 2026

Mr. Darin Saiff
District Superintendent
St. Lawrence-Lewis BOCES
40 W. Main Street
P.O. Box 231
Canton, NY 13617

Dear Mr. Saiff:

The Board of Education of the Gouverneur Central School District unanimously nominated Todd E. Bates as a candidate for election for a seat on the St. Lawrence-Lewis Counties BOCES Board. The Gouverneur Board took this action at their regular meeting held on Monday, February 9, 2026.

Todd was originally elected to the Gouverneur Board of Education in July 2020 and has served as Vice President since 2022. He received an associate degree in computer programming from SUNY Canton, then pursued a bachelor's degree in web development, completing that in 2014. His experience also includes IT positions at Fort Drum, SUNY Potsdam, SUNY Canton, and at Corning Incorporated, where he is currently employed as a Senior Systems Analyst/Systems Administrator. He has also served on the Gouverneur Technology Committee since 2019.

Todd's background makes him an ideal candidate who will use his analytical skills to observe, understand, and contribute to the diverse conversations around the Board table.

He and his wife, Paula, a reading teacher at Gouverneur Elementary School, reside in our community with their son, who is enrolled in the district.

I am confident that Todd will represent without bias all of the school districts in the St. Lawrence-Lewis BOCES.

I ask your Board's support of Todd in his campaign for election to the BOCES Board for another three-year term.

Sincerely,

Jacquelyn L. Kelly
Superintendent of Schools

Enclosure

BOCES NOMINATION FORM

Be it resolved, that the Board of Education of the Gouverneur Central School District hereby nominate Todd E. Bates of Gouverneur, New York, to fill a vacant seat on the St. Lawrence-Lewis Counties B.O.C.E.S. Board.

BIOGRAPHICAL SKETCH OF NOMINEE

Name: Todd E. Bates

Address: 55 Valley Dr. Gouverneur New York 13642

Education: Bachelor of Technology - Web Development - May 2014
Associate in Applied Science - Computer Programming - December 2001

Educational Experience: GCSK12 BOE 2022 - Present- Vice President
GCSK12 BOE 2020 - 2022 - Trustee
GCSK12 Technology Committee 2019 - Present

Work Experience:

- Senior Systems Analyst / Systems Administrator at Corning Incorporated
Canton Plant September 4, 2018 - Present
- Infrastructure Technician at SUNY Potsdam - Computing & Technology Services
October 16, 2017 -August 31, 2018
- Integrated Manufacturing Systems Technician Contractor at AccruePartners
October 31, 2016 - October 13, 2017
- Network Professional - CSRA /CSGov /CSC Warfighter Focus Training DoD
Contractor Fort Drum September 2015 - October 2016
- Network Technician/ PC Technician/ Multimedia Technician SUNY Canton
February 21, 2001 - September 15, 2015

Madrid-Waddington Central School

Nicole Miller
Elementary Principal



Eric Burke
Superintendent

Robert Smith
Board President

Joe Binion
High School Principal



March 5, 2026

Darin Saiff, District Superintendent
St. Lawrence-Lewis Counties BOCES
P.O. Box 231
Canton, NY 13617

At its regular meeting on March 17, 2026, the Madrid-Waddington Central School District Board of Education unanimously nominated Mickey Miller for consideration to serve on the St. Lawrence-Lewis BOCES Board.

Mr. Miller brings many years of experience in educational leadership and community service. He served on the Madrid-Waddington Board of Education from 2000 to 2014, including five years as Board President. During that time, he was actively engaged in district governance, helping guide the district through a range of financial cycles while contributing to the planning and oversight of several capital improvement projects. Since 2018, he has continued to support regional education through his service on the St. Lawrence-Lewis BOCES Board. He also previously represented local interests as a member of the New York Power Authority's Local Government Task Force.

A lifelong resident of the Madrid-Waddington community, Mickey and his wife Karen raised their three sons locally and remain deeply connected to the area. After a 28-year career with MX Petroleum, where he served as Operations Manager, Mr. Miller recently retired and now has additional time to dedicate to public service and educational initiatives.

Mr. Miller has also served the broader community in a number of leadership roles, including Village of Waddington Trustee and Deputy Mayor. He is an 18-year retired member and former Chief of the Waddington Volunteer Fire Department and previously served as Chair of the Waddington United Methodist Church Board of Trustees.

With his experience and perspective, Mr. Miller remains eager to continue working with regional partners to expand programming and create additional opportunities for students across the St. Lawrence-Lewis BOCES region. The Madrid-Waddington Central School District Board of Education respectfully recommends Mickey Miller and encourages your Board's support of his continued service on the St. Lawrence-Lewis BOCES Board.

Cordially,

A handwritten signature in blue ink, appearing to read 'Eric Burke', written over a light blue horizontal line.

Eric Burke
Superintendent of Schools

2582 State Highway 345 · PO Box 67 · Madrid, NY 13660 · www.mwesk12.org
phone: 315.322.5746
fax: 315.322.4462

BOCES NOMINATION FORM

Be it resolved, that the Board of Education of the Madrid-Waddington
(Central) (City) School District hereby nominates Michael G. Miller
of Waddington, New York, to fill a vacant seat on the St. Lawrence-
Lewis Counties BOCES Board.

BIOGRAPHICAL SKETCH OF NOMINEE

Name: Michael Miller

Address: P.O. Box 564
Waddington, New York 13694

Education: Regents diploma Madrid Waddington Central School
AAS SUNY Canton

Educational Experience (Board Service, etc):
Madrid Waddington Central School Board of Education - 14 years
SLL BOCES Board of Education - 2 terms
Waddington Village Board of Trustees- 2 terms
Waddington recreation committee- 15 years
Waddington Volunteer Fire Department- 18 years, past chief

Work Experience: MX Petroleum Corp. 28 years - retired

Miscellaneous Information:

Please return nomination form to:
Jennie Colburn, District Clerk
BOCES Sole Supervisory District
St. Lawrence-Lewis Counties
P.O. Box 231, 40 West Main Street
Canton, New York 13617

by Friday, March 20, 2026 (close of business)

Email: jennie.colburn@sllboces.org

Please email form or provide a hard copy via van mail.



MORRISTOWN CENTRAL SCHOOL

408 Gouverneur Street
Morristown, New York 13664
Phone: 315-375-8814
Fax: 315-375-8604
Website: www.greenrockets.org

Mr. Darin Saiff
District Superintendent
St. Lawrence-Lewis Counties BOCES
P.O. Box 231
Canton, NY 13617

Dear Mr. Saiff:

The Morristown Central School District Board of Education nominated Mr. Kevin M. Wells for re-election to the St. Lawrence-Lewis Counties BOCES Board at its regular Board of Education meeting on March 17, 2026.

A graduate of Gouverneur Central School District, Mr. Wells previously resided in the Edwards-Knox Central School District, where he served on that district's Board of Education for nearly fifteen years. In further support of Mr. Wells' nomination, it should be noted that he was previously elected to serve on the St. Lawrence-Lewis Counties BOCES Board and is now seeking re-election.

After a career spanning nearly thirty-six years, Mr. Wells retired from the St. Lawrence County Sheriff's Office, having served the past twelve years as the County's elected Sheriff. During his career in law enforcement, Mr. Wells provided training for D.A.R.E. officers, at the Police Academy, and for various police in-service programs. Across the region, he is a well-recognized public figure known for his professionalism and integrity.

Mr. Wells holds an A.A.S. from SUNY Canton and a B.P.S. in Criminal Justice from SUNY Utica-Rome. He now resides within the Morristown Central School District. He is the proud father of two adult children and grandfather of five.

Following a lengthy and respected career in law enforcement, along with many years of service on local Boards of Education and the BOCES Board, Mr. Wells has already given a great deal to public service. His decision to seek re-election demonstrates a continued dedication to supporting students and schools across the North Country. Mr. Wells brings both experience and a clear understanding of the issues facing today's youth, making him a strong advocate for our region's children.

I respectfully request your Board's support of Mr. Wells for re-election to the BOCES Board.

Sincerely,

A handwritten signature in blue ink that reads "Staci A. Vaughn".

Staci A. Vaughn
Superintendent of Schools

BOCES NOMINATION FORM

Be it resolved that the Board of Education of the Morristown Central School District hereby nominates **Mr. Kevin M. Wells** of Morristown, New York, to fill a vacant seat on the St. Lawrence-Lewis BOCES Board.

BIOGRAPHICAL SKETCH OF NOMINEE

Name: Mr. Kevin M. Wells

Legal Address: 286 Olds Mill Road, Ogdensburg, NY 13669

Mailing Address: PO Box 136, Morristown, NY 13664-0136

Education: Mr. Wells is a 1978 graduate of the Gouverneur Central School District. He has an A.A.S. degree in Criminal Justice from SUNY Canton and a B.P.S. degree in Criminal Justice from SUNY Utica-Rome. He has over 35 years of training in various topics in his professional years, including D.A.R.E. Instructor, Police Academy Instructor, and Police In-Service.

Educational Experience (Board Service, etc.): He was a member of the Edwards-Knox Central School District Board of Education for 15 years and at the end of June 2026 will have served as a member of the St. Lawrence-Lewis BOCES Board for the past six years.

Work Experience: Mr. Wells retired after working over 35 years with the St. Lawrence County Sheriff's Office. During the last 12 years of his career, he served as the Sheriff of St. Lawrence County.

Miscellaneous Information: Mr. Wells resides in the Town of Morristown with his partner, Mary Beth Curran. They have two adult children and five grandchildren.



Restaurant Equipment & Supplies

www.bgrestdsupply.com

(800) 696-4949

Albany
60 Commerce Avenue
Albany, NY 12206
(518) 482-2111

Rochester
100 Rawson Road
Victor, NY 14564
(585) 398-7224

Western MA
48 Eagle Street
Pittsfield, MA 01201
(413) 442-0390

Boston Metro
369 University Avenue
Westwood, MA 02090
(781) 467-0060

To:
Madrid-Waddington Central School
Eric Burke
315-322-5746 (Contact)

Project:
Madrid-Waddington Central School

From:
B&G RESTAURANT EQUIPMENT
Dan Moraldo
100 Rawson Road
Victor, NY 14564
585-398-7224
585-406-5689 (Cell)

Job Reference Number: 89681

NYS CONTRACT PC68656

Item	Qty	Description	Sell	Sell Total
3	1 ea	TILTING SKILLET BRAISING PAN, GAS Cleveland Range Model No. SGL40T1 PowerPan™ Tilting Skillet, gas, 40-gallon capacity, bead blasted cooking surface, 10° tilt cooking feature, with easy manual hand tilt, spring-assisted cover with vent, gallon & liter markings, stainless steel construction with open leg frame, 200,000 BTU, CE, NSF	\$22,525.00	\$22,525.00
	1 ea	1-year parts & labor warranty, standard		
	1 ea	K-12 WARRANTY Extended Warranty, not to exceed 36 months from date of installation (K-12 Schools only)		
	1 ea	K-12 PAN WARRANTY 10 Year Pan Warranty (K-12 Schools only)		



Item	Qty	Description	Sell	Sell Total
	1 ea	PERFORMANCE START-UP Performance start-up included at customer request after equipment is installed (free water quality check included) (mileage capped at 100 miles round trip) (contact Cleveland sales representative for details)		
	1 ea	New construction		
	1 ea	Natural Gas		
	1 ea	Standard wattage		
	1 ea	120v/60/1-ph, 1.4 amps, NEMA 5-15P, standard		
	1 ea	INSTKGTLP 3/4" Quick Disconnect, for all gas Kettles & Tilt Skillets include 3/4" gas line & quick disconnect hose, 3/4" street elbow, cable with mounting bracket, all gas kettles and tilt skillets come with 120 volt cord, plug	\$279.00	\$279.00
	1 ea	Standard controls, temperature control dial, LED ON indicator light, main power switch with standard and high power setting, standard		
	1 ea	TD2SK 2" tangent draw-off valve, front mounted left side	\$680.00	\$680.00
	1 ea	PCS Pan Carrier, for floor models	\$695.00	\$695.00
	1 ea	DRAINPAN6 Drainpan Assembly includes: 12" x 20" x 6" deep stainless steel pan with elbow, 8' x 2" hose & hose clamp (pan carrier sold separately)	\$460.00	\$460.00
	1 ea	DKFK Dual Pantry Faucet, with hose & nozzle hook, 68" stainless steel hose	\$1,360.00	\$1,360.00
	1 ea	INSTWATER 2 x 3/4" Female 6 ft Garden Hoses, 2 x 1/2" Male NPT to 3/4" Male Garden Hose NPT Fittings	\$80.00	\$80.00
	1 ea	FBST1 Faucet Bracket for T1 series floor model skillets	\$220.00	\$220.00
	1 ea	FSSK Food Strainer, for SGL/SEL, 30/40 Gallon tilting skillets	\$350.00	\$350.00
			ITEM TOTAL:	\$26,649.00
			Total	\$26,649.00

This is a drop ship quotation.
 Customer is responsible for the following:
 *Unloading of merchandise from truck
 *Inspecting for freight damage. If damage is found, customer is responsible to file a freight claim and mark the bill of lading "DAMAGED"

Acceptance: _____ Date: _____

Printed Name: _____

Project Grand Total: \$26,649.00

Cleveland

POWERPAN™ SERIES

GAS, 35" RIM HEIGHT,
30 & 40 GALLON (110 & 150 LITER)

Project _____
Item _____
Quantity _____
FCSI Section 11400 _____
Approved _____
Date _____

Braising Pans / Tilting Skillets

Models

- SGL-30-T1
- SGL-40-T1

Shown with
Standard
Controls



easyDial and
Core Temperature
Probe options

- Exclusive Dual Power Settings: 90,000 and 125,000 Btu for 30 gallons, 160,000 Btu and 200,000 Btu for 40 gallons provides superior heat-up and recovery.
- Open base design for easy cleaning and maintenance.
- 5/8" Stainless Steel Bead Blasted cooking surface prevents warping and keeps food from sticking.
- Durable 12 gauge, 304 Stainless Steel pan construction. 5/8" (16mm) mild steel clad bottom plus a 1/16" (1.6mm) Stainless Steel plate for even temperature distribution.
- Low 35" rim height for easy operation and cleaning.
- Splash Proof Controls and construction.
- Supplied with Cord & Plug for 115-volt controls.
- Easy-to-turn manual hand tilt with enclosed permanently lubricated gearbox. Optional power tilt with manual override available.
- Gallon/Liter Markings and Vented Spring Assist Cover standard.
- Available with Optional 2" Tangent Draw-Off Valve.
- 10° Cooking Feature. Tilt unit up to 10° without the power being turned off.
- Adjustable Solid State Thermostat accurately controls temperature from 140°F to 425°F.

Standard Control Panel includes:

Temperature Control Dial, LED ON Indicator Light, Main Power Switch with Standard and High Power Settings.

easyDial Control Panel (optional) includes:

Selector Dial with LED Ring, Large Display Screen, Three Cooking Modes, Built-In Self-Diagnostics and Display, Temperature Select Button, Timer Set Button (Hrs/Min), Settings Button, Main Power Button, Probe Connection Port, LED Indicator Lights for Heat-ON, Product Probe, Temperature, Time, Settings, Self-Diagnostics, Ignition Failure, Std and High Power Setting.

- Electronic "Spark Ignition System Standard".
- Spring-Assist Cover with full width handle and vent.
- Typical approvals include AGA, CSA, CE and NSF.

Short Form Specifications

Shall be CLEVELAND, Tilting Skillet Model Number SGL-___-T1, gas (type ___) holding no less than ___ gallons (___ liters); Complete with Dual Power Setting, Normal and High Power Cooking Controls, Power Burner (Forced-Air) Gas Combustion System, Automatic Ignition, Splash-Proof Construction, Spring Assist Cover with Vent, Gallon/Liter Markings, 5/8" Stainless Steel Clad Cooking Surface with Bead Blasted Finish, Easy to use Manual Hand Tilt with Enclosed Permanently Lubricated Gearbox, Adjustable Feet with Rear Flanged and Front Bullet Style.

Standard Features

- Available in 30 & 40 gallon (115 & 150 liter) open frame design models. Full capacity to bottom of pouring lip.
- Exclusive Ultra Efficient Power Burner (Forced-Air) Gas Combustion System with Automatic Ignition.

Options & Accessories

- easyDial Control
- Core Temperature Probe Option
- Power Tilt with Manual Override (PT2)
- 2" (50 mm) Tangent Draw-Off Valve (TD2SK), left side only
- Double or Single Pantry Faucet (SPS14, DPS14), includes Faucet Mounting Bracket
- Faucet Bracket (FBKT1)
- Pan Carriers (PCS), not available on 30 gallon models with a Tangent Draw-Off Valve
- Vegetable Steamer Baskets (VS)
- Hot & Cold Water Pre-Rinse Spray Head with Hose (PRS-S)
- Poaching Pans (PP)
- Voltage Option:
 - VOSK3, 440/480 Volt, 60 Hz, 3 Phase
 - VOSK4, 220/240 Volt, 50 Hz, 1 Phase - for export
- Protective Control Cover (CP-PCB-T1)
- Casters, 2 swivel, 2 locking (CST1)

KE004046-92C

760 Beta Drive, Unit D
Mayfield Village, Ohio 44143

Tel 1.216.481.4900
Fax 1.216.481.3782
Email steam@clevelandrange.com

www.clevelandrange.com
Section 9, Page 13
5673A 4 / 2025

Timeless Quality, Trusted For Life®

Cleveland

Braising Pans / Tilting Skillets

DIMENSIONS

MODEL	A	B	C	D	E	E	F	G	H
					(combustible wall)	(non-combustible wall)			
SGL-30-T1	37 7/8"	24 1/2"	31 3/4"	12"	3 1/2"	2"	18 1/4"	5 3/4"	8"
	(963mm)	(623mm)	(807mm)	(305mm)	(89mm)	(50.8mm)	(464mm)	(146mm)	(204mm)
SGL-40-T1	49 7/8"	36 1/2"	43 3/4"	18"	3 1/2"	2"	24 1/4"	5 3/4"	8"
	(1267mm)	(928mm)	(1112mm)	(458mm)	(89mm)	(50.8mm)	(616mm)	(146mm)	(204mm)

SPECIFICATIONS

ELECTRICAL SUPPLY		GAS SUPPLY (PIPING 3/4" NPT)		CLEARANCE	
VOLTS:	120 220/240	TYPE:	NAT or LP	RIGHT:	
PHASE:	1 1	WATER COLUMN:	3.5 (NAT), 10 (LP)	4" (102mm) (manual tilt)	
AMPS:	1.4 1.5	BTU PER CU. FT.:	1025 (NAT), 2500 (LP)	1" (26mm) (power tilt)	
FREQ:	60 HZ 50 HZ	SUPPLY PRESSURE:		LEFT: 0"	
		5" W.C. MIN (NAT), 11" W.C. MIN (LP)		REAR: 2" (50.8mm) (non-combustible wall)	
		BTU RATINGS:		3.5" (89mm) (combustible wall)	
		SGL-30-T : 125,000 per hour			
		SGL-40-T : 200,000 per hour			

CAPACITIES

In 4 oz. servings. Other sizes may be calculated.
 30 gallons / 115 Liters.....960
 40 gallons / 150 Liters.....1280



Standard Control Panel



easyDial Control Panel with Core Temperature Probe

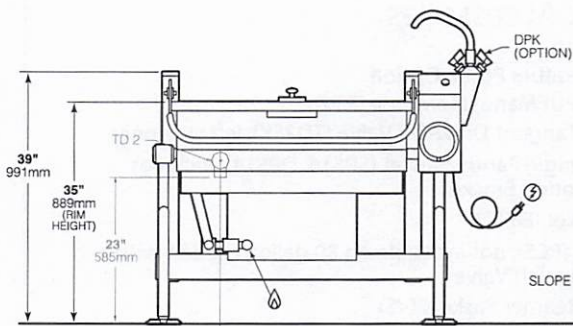
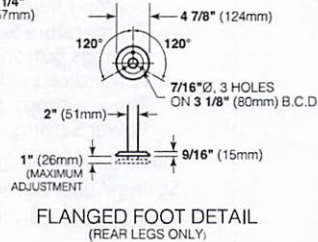
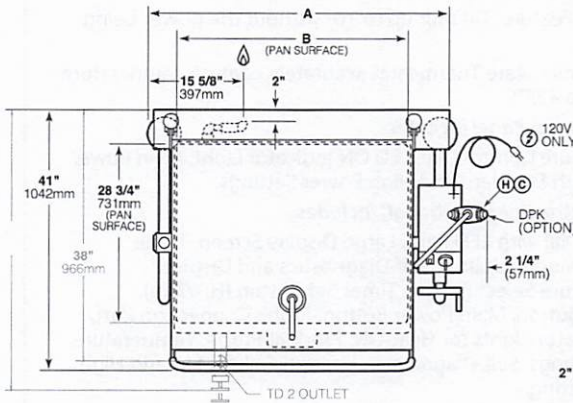

NOTE: OPTIONAL 2" TD VALVE SHOWN IN GRAY

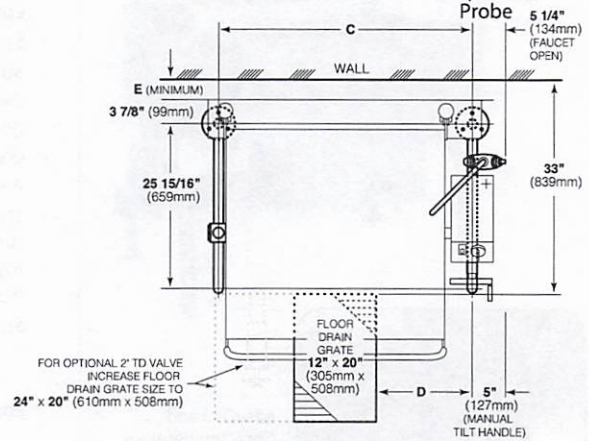

LEG LOCATION & SUGGESTED FLOOR DRAIN DETAIL

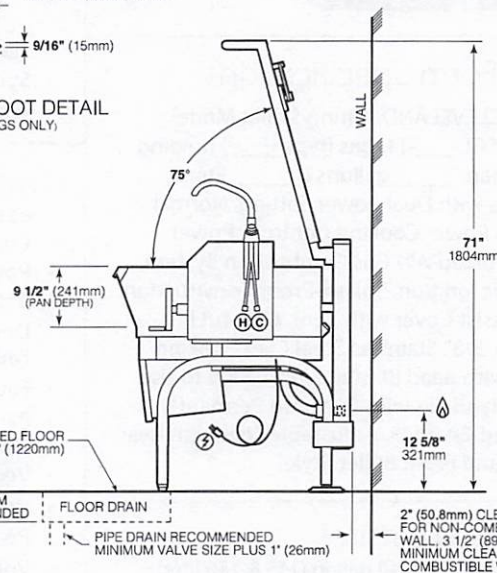

NOTES:

Cleveland Range reserves right of design improvement or modification, as warranted.
 Many regional, state and local codes exist and it is the responsibility of the owner and installer to comply with the codes.
 Cleveland Range equipment is built to comply with applicable standards for manufacturers. Included among those approval agencies are U.L., NSF, CGA, CSA, ETL and others.

(NOT TO SCALE)

Project _____
 Item _____
 Quantity _____
 FCSI Section 11400 _____
 Approved _____
 Date _____

2" DRAIN PAN ASSEMBLY FOR TILTING KETTLES AND SKILLETTS

Models

- DRAINPAN6 *



Standard Features

- Ideal for tilting kettles and skillets that do not have a floor drain. The 6" deep solid stainless steel drain pan easily mounts inside a Cleveland Pan Carrier (PCS). The 8' long hose (trim to required length) can be positioned to a remote floor drain.
- For tilting kettles and skillets

Model "DrainPan6" includes:

- 6" x 12" x 20" Stainless Steel Solid Pan with Elbow
- 8' length of 2" ID Hose (HO8.2) (cut to required length)
- Hose Clamp

* NOTE: Pan Carrier (PCS) sold separately



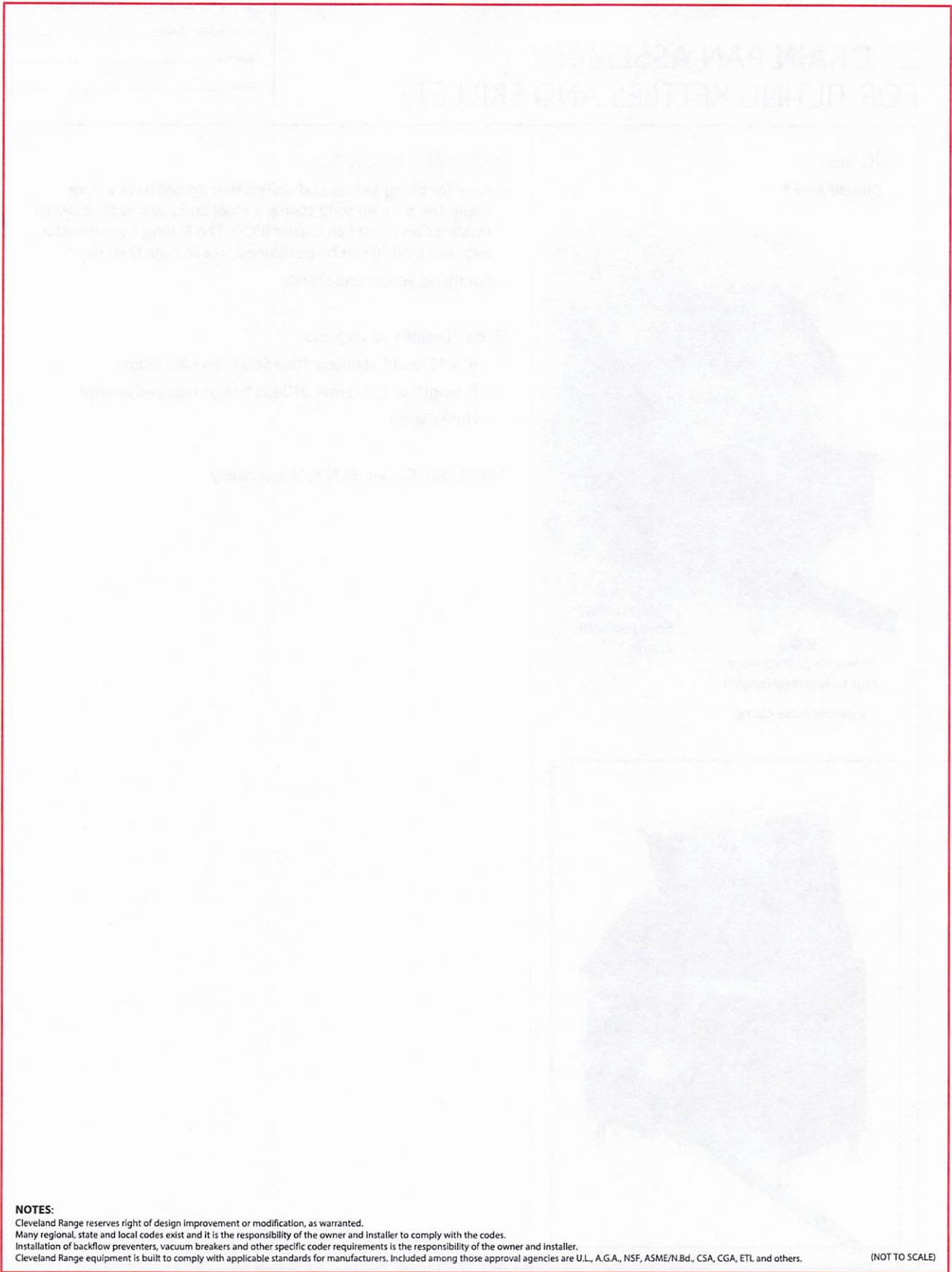

NOTES:

Cleveland Range reserves right of design improvement or modification, as warranted.
 Many regional, state and local codes exist and it is the responsibility of the owner and installer to comply with the codes.
 Installation of backflow preventers, vacuum breakers and other specific code requirements is the responsibility of the owner and installer.
 Cleveland Range equipment is built to comply with applicable standards for manufacturers. Included among those approval agencies are U.L., A.G.A., NSF, ASME/N.Bd., CSA, CGA, ETL and others.

(NOT TO SCALE)

Cleveland

DKFK - Double Pantry Faucet with Hose & Hook Nozzle

Project _____
Item _____
Quantity _____
FCSI Section 11400 _____
Approved _____
Date _____

Models

- DKFK - Double Pantry Faucet with Hose & Hook Nozzle



Standard Features

Single-hole deck mount mixing faucet with polished chrome plated brass body for durability and easy installation.

68" flexible stainless steel hose with heat-resistant handle and wall hook for extended reach and convenience.

Self-closing pot filler valve with hook nozzle for quick rinsing tasks in busy kitchen environments.

Quarter-turn ceramic cartridges with check valves to prevent cross-flow and ensure smooth operation.

18" supply hoses with compression connections; low-lead, commercial-grade design ideal for foodservice use.

Not installed at the factory

Faucet Bracket (FBKT) - required for mounting to Cleveland Range Model

Install Kit (INSTWATER) - 2 x $\frac{3}{4}$ " Female 6 ft Garden Hoses, 2 x $\frac{1}{2}$ " Male NPT to $\frac{3}{4}$ " Male Garden Hose NPT Fittings

DKFK

Cleveland

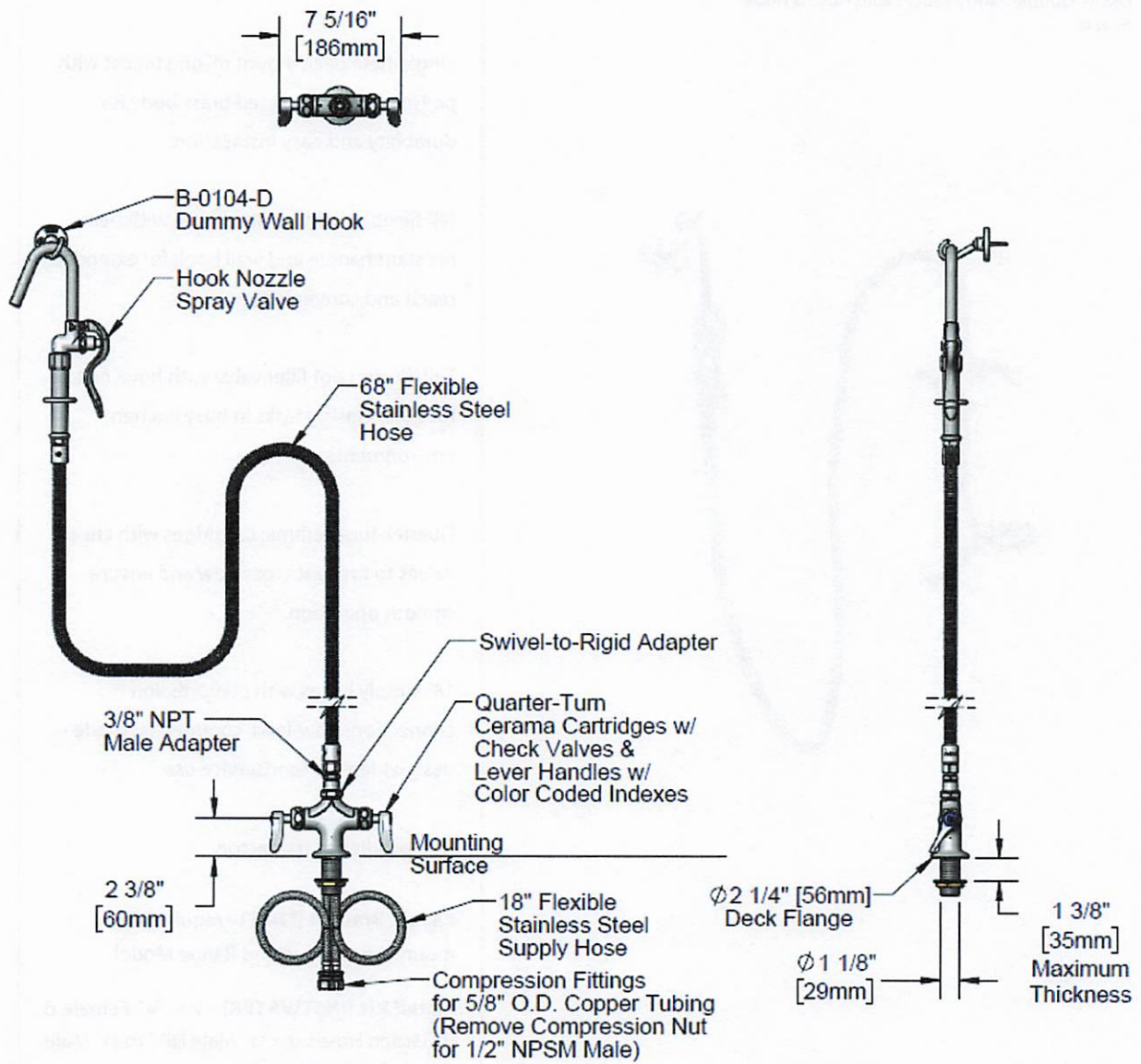

(NOT TO SCALE)

DKFK

760 Beta Drive, Unit D
Mayfield Village, Ohio 44143

Tel: 1-800-338-2204
Email: steam@clevelandrange.com

www.clevelandrange.com
12/2025

Timeless Quality, Trusted For Life®



Packing List
INSTALLATION KIT
WATER FAUCET INSTALL KIT

ID# 25872

WELBILT P/N: INSTWATER

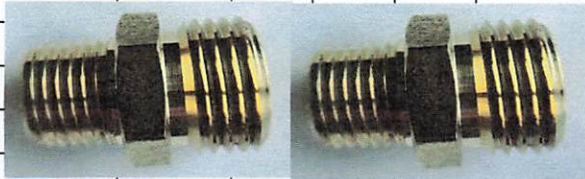
Item	ID #								Qty per kit
1	24303	3/4" NSF FEMALE X FEMALE GARDEN HOSES 6' LONG							2
									
2	24948	3/4 MGH x 1/2 NPT Brass Male							2
									

Cleveland

FSSK - T1/TR Skillet Strainer

Project _____

Item _____

Quantity _____

FCSI Section 11400 _____

Approved _____

Date _____

Standard Features

- Tilting Skillet/Braisin Pan Food Strainer for all T1 and TR Cleveland Range models
- 30/40 Gallons
- 21" (w) x 9.5" (h)
- Easily strain all over your soups, stews, liquids

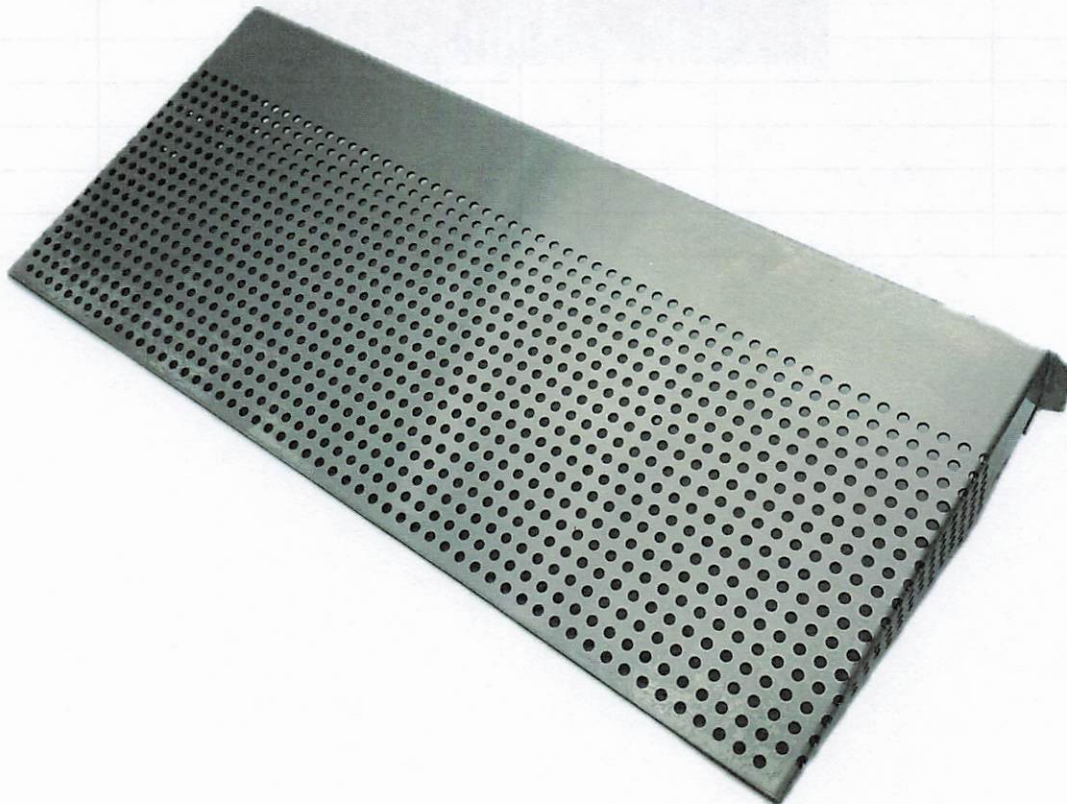

FSSK



Roth Consulting Group, Inc.
 Commercial Foodservice Facilities Design
 424 Bewley Building, Lockport, NY 14094
 P: 716-433-5111, F: 716-433-5355

Budget Costing

03/19/2026

Project:
 Madrid Waddington - Kettle

From:
 Roth Consulting Group
 Linda Roth
 424 Bewley Building
 Lockport, NY 14094
 7164335111

Job Reference Number: 296

Item	Qty	Description	Sell	Sell Total
1	1 ea	KETTLE, GAS, TILTING	\$21,049.84	\$21,049.84
		 Cleveland Range Model No. KGL40T Kettle, gas, tilting, 40-gallon capacity, 2/3 steam jacket design, 316 stainless steel interior, floor mounted control console supports, 304 stainless steel construction, flanged feet, 50 psi rating, electronic spark ignition, cover & draw-off optional, 140,000 BTU, CE		
	1 ea	1-year parts & labor warranty, standard		
	1 ea	K-12 WARRANTY Extended Warranty, not to exceed 36 months from date of installation (K-12 Schools only)		
	1 ea	K-12 PAN WARRANTY 10 Year Pan Warranty (K-12 Schools only)		
	1 ea	PERFORMANCE START-UP Performance start-up included at customer request after equipment is installed (free water quality check included) (mileage capped at 100 miles round trip) (contact Cleveland sales representative for details)		
	1 ea	Natural Gas		
	1 ea	120v/60/1-ph, 10.0 amps, electronic spark ignition, cord & plug for controls, standard		
	1 ea	Standard controls, temperature control dial, LED ON indicator light, main power switch with standard and high power setting, standard		
	1 ea	TD2 2" tangent draw-off valve with strainer	\$927.36	\$927.36
	1 ea	KM2G Kettle Markings, 5 gallon increments	\$449.68	\$449.68
	1 ea	CHS40 Spring-assisted cover (40 gallon)	\$1,127.84	\$1,127.84
	1 ea	DPK25 Double Pantry Faucet And Bracket Kit (KGL25T, KGL40T, KGL60T, KGL80T, KGL40TSH)	\$460.88	\$460.88
	1 ea	KAK Kettle Accessory Kit includes: clean-up brush, 36" kettle paddle, stainless steel kettle whip, 36" nylon kettle brush, nylon draw-off brush, & 18" stainless steel 24 oz kettle ladle	\$932.96	\$932.96
ITEM TOTAL:				\$24,948.56
			Merchandise	\$24,948.56
			Freight	\$322.20
			Total	\$25,270.76

Manufacturer Summary

Mfr	FOB	ZIP	Class	Weight	Good Until	Terms	Notes
Cleveland	Covington	38019	85	537			
Cleveland	Mayfield Village	44143	85				

Entity Name: MADRID-WADDINGTON CSD
 BEDS Code: 511901
 Claim Year: 2025-2026



Welcome JULIE K BRESETT (School Entity User) CORE 04/15/2026 06:34 AM Home | Issue Reporting | Help | Logout

You Have Selected the 'Official' Data Area.

[Print Legacy](#) | [Print Form](#) | [Print Blank](#) | [Print Text Only](#)

District Name: MADRID-WADDINGTON CSD
 Contact Person: ERIC BURKE

District Code: 511901
 Telephone: (315) 322-5746
 Tel Extension: 35221

Form Saved Successfully on 04/15/2026 06:34:55 AM

Property Tax Report Card

****Please use Chrome or Firefox browsers when entering the Business Portal to complete the PTRC. Internet Explorer is NOT recommended.****

Note: Some data elements of the Property Tax Report Card have been revised or renamed to more closely follow the Property Tax Cap calculations districts complete on the Office of the State Comptroller website. Please see the Help text above for definitions. Additional guidance on the Property Tax Levy Limit is available on the Office of Educational Management Services website: <http://www.p12.nysed.gov/mgt/serv/propertytax/taxcap/>.

Please also submit an electronic version (PDF or Word) of your school district's 2026-27 Budget Notice to: emscmgts@nysed.gov. This will enable us to help correct any formula or data entry discrepancy quickly.

Notice: The Enacted Budget allows school districts to establish a reserve fund for NYS Teachers' Retirement System Contributions, effective immediately. This reserve, if applicable, should be reported in the Schedule of Reserves under 'Other Reserve' and with a description that says: "To fund employer retirement contributions to the New York State Teachers' Retirement System (TRS)."

Form Due - April 25, 2026

Form Preparer Name: JULIE ABRANTES
 Preparer's Telephone Number: 315-322-5746

<u>Shaded Fields Will Calculate</u>	Budgeted 2025-26 (A)	Proposed Budget 2026-27 (B)	Percent Change (C)
Total Budgeted Amount, not including Separate Propositions	21,500,940	23,577,895	9.66 %
A. Proposed Tax Levy to Support the Total Budgeted Amount ¹	4,985,334	5,147,334	
B. Tax Levy to Support Library Debt, if Applicable	0	0	
C. Tax Levy for Non-Excludable Propositions, if Applicable ²	0	0	
D. Total Tax Cap Reserve Amount Used to Reduce Current Year Levy, if Applicable	0	0	
E. Total Proposed School Year Tax Levy (A+B+C-D)	4,985,334	5,147,334	3.25 %
F. Permissible Exclusions to the School Tax Levy Limit	153,267	352,140	
G. School Tax Levy Limit, <u>Excluding</u> Levy for Permissible Exclusions ³	4,889,566	4,968,880	
H. Total Proposed Tax Levy for School Purposes, <u>Excluding</u> Permissible Exclusions and Levy for Library Debt, Plus Prior Year Tax Cap Reserve (E-B-F+D)	4,832,067	4,795,194	
I. Difference: (G-H); (negative value requires 60.0% voter approval) ²	57,499	173,686	
Public School Enrollment	602	616	2.33 %
Consumer Price Index			2.63 %

¹ Include any prior year reserve for excess tax levy, including interest.
² Tax levy associated with educational or transportation services propositions are not eligible for exclusion under the School Tax Levy Limit and may affect voter approval requirements.
³ For 2026-27, includes any carryover from 2025-26 and excludes any tax levy for library debt or prior year reserve for excess tax levy, including interest.

	Actual 2025-26 (D)	Estimated 2026-27 (E)
Adjusted Restricted Fund Balance	3,831,748	3,907,753
Assigned Appropriated Fund Balance	1,170,188	1,370,188
Adjusted Unrestricted Fund Balance	851,008	850,236
Adjusted Unrestricted Fund Balance as a Percent of the Total Budget	3.96 %	3.61 %

Reserve Type	Reserve Name	Reserve Description *	3/31/26 Actual Balance	6/30/26 Estimated Ending Balance	Intended Use of the Reserve in the 2026-27 School Year (Limit 200 Characters)**
Capital + (add)	CAPITAL	For the cost of any object or purpose for which bonds may be issued.	1,895,321	1,905,000	At this time, the district plans to use a portion of the reserve to offset future building improvements and equipment/vehicle purchases.
Repair		For the cost of repairs to capital improvements or equipment.			
Workers Compensation		For self-insured Workers Compensation and benefits.			
Unemployment Insurance	UNEMPLOYMENT	For reimbursement to the State Unemployment Insurance Fund.	42,837	45,000	At this time, the district plans to use a portion of the reserve to offset future unemployment claims.
Reserve for Tax Reduction		For the gradual use of the proceeds of the sale of school district real property.			
Mandatory Reserve for Debt Service	DEBT SERVICE	For proceeds from the sale of district capital assets or improvement, restricted to debt service.	757,352	762,000	At this time, the district plans to use a portion of the reserve to offset payments on debt obligations due in 2026-2027.
Insurance	INSURANCE	For liability, casualty, and other types of uninsured losses.	814,390	820,000	At this time, the district plans to use a portion of the reserve to offset future insurance costs or changes of insurance plans.
Property Loss + (add)		To cover property loss.			
Liability + (add)		To cover incurred liability claims.			
Tax Certiorari	TAX CERTIORARI	For tax certiorari settlements.	0	50,000	At this time, the district plans to use funds to offset future tax certiorari settlements.
Reserve for Insurance Recoveries		For unexpended proceeds of insurance recoveries at fiscal year end.			
Employee Benefit Accrued Liability	EMPLOYEE BENEFITS	For accrued 'employee benefits' due to employees upon termination of service.	204,207	207,000	At this time, the district plans to use a portion of the reserve to offset future benefits to retirees per contractual language.
Retirement Contribution		For employer retirement contributions to the State and Local Employees' Retirement System.			
Reserve for Uncollected Taxes		For unpaid taxes due certain city school districts not reimbursed by their city/county until the following fiscal year.			
Single Other Reserve + (add)	RETIREMENT - NYSTRS	To fund employer retirement contributions to the NYS Teachers' Retirement System	76,888	78,000	At this time, the district plans to use a portion of the reserve to offset future NYSTRS invoices.

* NYSED Reserve Guidance: http://www.p12.nysed.gov/mgtserv/accounting/docs/reserve_funds.pdf

OSC Reserve Guidance: <http://osc.state.ny.us/localgov/pubs/listacctg.htm#reservefunds>

**Provide a brief, but specific, statement of the planned use and appropriation for the reserve in SY 2026-27. Mention any capital expenditures that will need to be voted upon in the upcoming Budget Vote.



Madrid Waddington Central School
2582 NY-345
Madrid, NY 13660

RE: Contract Agreement for ESY 26-27 Occupational Therapy and Physical Therapy Services

TO WHOM IT MAY CONCERN:

This agreement made this 16 day of April 2026 between North Coast Occupational, Physical and Speech Therapy PLLC (NCT) and Madrid Waddington Central School District (MWC) where NCT will provide Occupational Therapy and Physical Therapy services and where MWC wishes to enter an agreement for such services is mutually agreed to as the following:

NCT will provide Occupational Therapy and Physical Therapy services to referred students in accordance with their respective IEP at school for ESY 2026-2027. Services will include treatment, and related treatment support, i.e., parent conferences, Committee Meetings, IEP's, and interagency contacts. MWC will provide the necessary orders from the child's physician prescribing Occupational Therapy and Physical Therapy services. NCT will provide session notes to MWC in a timely fashion. NCT will invoice MWC monthly at a rate of ninety dollars per visit.

MWC will provide NCT with complete IEP's on all students referred for services. MWC shall pay the amount invoiced within thirty (30) days of receiving invoice.

If this is an acceptable agreement please sign and return a copy of this at your earliest convenience. We look forward to serving the students of Madrid Waddington Central School with the highest quality of Occupational Therapy and Physical Therapy services. Please feel free to call if you have any questions.

Sincerely,

Kim Thompson

Karen Cameron

as agreed by: _____

Date: ___/___/___

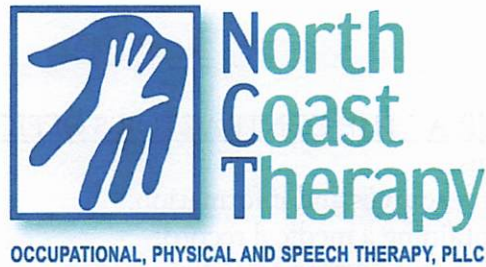

THIS AGREEMENT, made this 16 day of April 2026, between:

North Coast Occupational, Physical and Speech Therapy, PLLC (NCT), OF 10 Hospital Drive, Massena NY hereinafter referred to as “Contractor,” and

Madrid Waddington Central (MWC) of 2582 NY-345, Madrid NY 13660 hereinafter referred to as “Contractee”

WITNESSETH:

WHEREAS, the Contractor provides Physical Therapy and Occupational Therapy and

WHEREAS, the Contractee wishes to enter into an agreement for the providing of such services.

1. **NOW, THEREFORE**, in consideration of the mutual terms and conditions of this Agreement, it is agreed by and between the parties as follows:

The Contractor agrees to provide the Contractee Physical Therapy and Occupational Therapy. The Contractor shall employ all personnel, who in turn will follow all Rules and Regulations of the Contractor. Any personnel employed by the Contractor shall be certified by the University of the State of New York, for Professional Practice in New York State, as an Physical Therapist or an Physical Therapist Assistant; Occupational Therapist or an Occupational Therapy Assistant; and no person lacking such certification shall be employed by the Contractor. The Contractor shall provide Physical and Occupational Therapy within the Contractee agency setting. The following are the examples of activities which will be performed by the Contractor’s personnel.

A ACTIVITIES AT SCHOOL:

- 1) Direct therapeutic services with the children (evaluation, screening, or treatment);
- 2) Participation in School based Committee Meetings and IEP/CPSE Meetings as requested;
- 3) Instructing personnel in management and follow through activities such as positioning, and feeding programs;
- 4) In-Service Education Programs for school personnel as arranged by the Educational Directional Director
- 5) Consultation regarding: adaptations of environment, or materials; special equipment; activity programs such as adaptive physical education; resources available for the child.
- 6) Conferences with parents (may be done in their homes);
- 7) Conferences with teachers regarding progress.

B. ACTIVITIES THAT MAY OCCUR AT THE CONTRACTOR'S OFFICES:

- 1) Writing of reports and evaluations;
- 2) Making interagency contacts for resources and information;
- 3) Writing progress notes and maintaining a medical record;
- 4) Following up on special services such as orthopedic clinic;
- 5) Providing direct therapeutic services when deemed appropriate;
- 6) Maintaining necessary statistical records.

C. FOR HOMEBOUND STUDENTS, SERVICES MAY BE PROVIDED AT THE CHILD'S HOME.

2. The contractor shall also perform the following services:

- a) Provide qualified professional and administrative supervision of all activities undertaken by the Contractor's personnel;
 - b) Maintain written records of all client contacts, at the Contractor's offices, with original records furnished to the Contractee. It is understood that all records generated by the Contractor with respect to individual students are the sole property of the Contractee;
 - c) Assure that all activities performed by the Contractor's Personnel shall conform with current New York State Physical Therapy, Occupational Therapy and Speech Language Pathology Practice Acts;
 - d) Be liable for actions made in performance of duties by those personnel hired by the Contractor, and for the Contractor;
 - e) Provide the Contractee with a monthly statement of services and charges showing client contacts and hours worked;
 - f) Provide Malpractice Insurance at the Contractor's cost and expense, in an amount of at least one million dollars, for each claim and three million dollars, in aggregate, and the Contractee shall be listed as an additional insured, receive a copy of all policies of insurance and receive written notification one month in advance of any changes or termination in any policy;
 - g) The Contractor shall indemnify and hold harmless the Contractee from any and all claims arising out of the Contractor's services provided for herein;
2. The Contractee shall pay the contractor the sum of ninety dollars (\$95.00) per hour. Work under this agreement shall include travel time between schools, student absences, planning time, dication and any other work done in support of the Contractee (meetings, annual testing, consultations with parents/teachers, scheduling, co-signing of notes) during the contractual period. The Contractee will pay 5 minutes per note for each visit. The Contractee will pay for supervisory visits completed by the contractor. The contractor shall submit a statement of the Contractee, and the Contractee shall pay the amount due, pursuant to said statement, by the 10th day following receipt by the Contractee of the statement.

4. The term of this Contract will be for the period from September 1, 2026, through on or about June 30, 2027, and automatically renews. Notwithstanding the foregoing, either party may terminate this agreement by providing the other party with not less than ninety (90) day advance written notification on an intention to do so forwarded to the other party by Certified Mail Return Receipt Requested, at the address listed above.
5. The Contractee shall provide adequate and appropriate operational space for the Contractor and the Contractor's personnel, to provide appropriate services.
6. Any fabrication of adaptive equipment, orthotic or custom made devices, will be charged separately, on the Contractor's Statement, subject to the prior written approval of the Contractee.
7. Both the Contractor and Contractee shall mutually agree on the following:
 - a) The clients who are to receive services;
 - b) The schedule through which services shall be provided; and
 - c) The scheduling of personnel.
8. The Contractor shall conform to all Provisions of the New York State Education Law, the Commissioner's Regulations and the Health Insurance Portability and Accountability Act of 1996. The Contractor employees will be comply with fingerprinting requirements.
9. Neither party may assign any rights or delegate any duties hereunder, other than an provided for herein, without express prior written consent of the other.
10. Contractor is retained by the Contractee only for the purposes and to the extent set forth in this Agreement and the Contractor's relation to the Contractee shall, during the period of services hereunder, be that of an Independent Contractor.
11. Contractee shall not offer employment or hire any Contractor employee for a period of two years following the end of this agreement.
12. This writing contains the entire Agreement between the parties.
13. The failure of either party to this Agreement to object to or take affirmative action with respect to any conduct of the other, which is in violation of the terms of this Agreement, shall not be constructed as a waiver of the violation or breach, or any future violation, breach, or wrongful conduct.
14. The Contractor shall be responsible for Worker's Compensation and Disability Benefits Insurances, on themselves and the personnel that they employ. The Contractee shall not be responsible for any State and Withholding and Social Security Taxes, which will be the responsibility of the Contractor. The Contractee shall not be responsible to provide any fringe benefits to the Contractor, or their personnel, that are available to the regular employees of the Contractee, and the Contractor waives any and all claims therefore.

Confidentiality Agreement

This Confidentiality Agreement (“Agreement”) is entered into as of April 16, 2026 by and between North Coast Occupational, Physical and Speech Therapy PLLC {North Coast Therapy LLC (“NCT”)} and Madrid Waddington Central School (MWCS)

WHEREAS, NCT acknowledges that MWCS has in its possession data that contains individually identifiable health information as defined by the Health Insurance Portability and Accountability Act of 1996, including, but not limited to, patient medical insurance and third-party payer’s of patient medical bills, patient and hospital financial information, and patient and employee demographics.

WHEREAS, NCT and MWCS are parties to an agreement, pursuant to which the fulfillment of parties’ agreement obligations necessitates the exchange of, or access to, data in MWCS’s information systems that includes Individually Identifiable Health Information (IIHI).

THEREFORE, MWCS is willing to permit NCT access to such information, subject to the following conditions:

1. NCT acknowledges that all Protected Health Information (PHI) in the possession of MWCS is confidential and the property of MWCS.
2. NCT agrees to not use or further disclose PHI other than as permitted or required by this Agreement or as required by Law. This includes establishing, maintaining and using appropriate safeguards to prevent use or disclosures of PHI to MWCS that are not provided for by this Agreement; enforcing and maintaining appropriate policies, procedures and access controls to ensure that any third-party agent agrees to the same conditions that apply to NCT with respect to such information insuring that access privileges granted to third-party agents are minimum necessary to perform assigned functions; maintaining documentation of uses and disclosures of PHI received from MWCS; and providing information in a timely manner to MWCS who receives requests from individuals for PHI accounting.
3. In the event that NCT is required by law to disclose PHI received from MWCS, NCT must immediately provide MWCS with a written notice concerning the request so that NCT has an opportunity to challenge the request.
4. Both parties agree that any breach of the confidentiality agreement will result in irreparable damage such that no remedy at law will be adequate. As such, it is agreed that MWCS is entitled to equitable relief. Any ruling concerning the agreement breach by a court or competent jurisdiction will be without prejudice to any other right or remedy to which MWCS may be entitled, including damages. NCT agrees to hold MWCS blameless for any and all claims for personal injury resulting from any disclosure of information by NCT or NCT’s agents to any third-party in violation of the terms of this Agreement.
5. MWCS retains the right to terminate this Agreement and deny NCT access to information containing PHI without notice whenever MWCS has determined that NCT, its agents or employees, has violated any of the provisions of the Agreement. NCT also agrees that MWCS will not be liable for any damages NCT suffers as a result of NCT’s inability to access MWCS’s information systems.

6. The obligation to maintain the confidentiality of the information survives the termination of this Agreement.
7. NCT agrees that MWCS does not guarantee NCT the accuracy of any data contained in MWCS's information systems.

IN WITNESS WHEREOF, the parties have signed this Agreement, as of the day and year first above written.

Karen Cameron, Physical Therapist, Managing Member
Kim Thompson, Speech Therapist, Managing Member

North Coast Occupational, Physical and Speech Therapy PLLC
(North Coast Therapy LLC)

Madrid Waddington Central School District

By _____

Date: _____